

Кориолисовые массовые расходомеры Subemass DCI

Технические характеристики

По вопросам продаж и поддержки обращайтесь:

Алматы (7273)495-231
Ангарск (3955)60-70-56
Архангельск (8182)63-90-72
Астрахань (8512)99-46-04
Барнаул (3852)73-04-60
Белгород (4722)40-23-64
Благовещенск (4162)22-76-07
Брянск (4832)59-03-52
Владивосток (423)249-28-31
Владикавказ (8672)28-90-48
Владимир (4922)49-43-18
Волгоград (844)278-03-48
Вологда (8172)26-41-59
Воронеж (473)204-51-73
Екатеринбург (343)384-55-89

Иваново (4932)77-34-06
Ижевск (3412)26-03-58
Иркутск (395)279-98-46
Казань (843)206-01-48
Калининград (4012)72-03-81
Калуга (4842)92-23-67
Кемерово (3842)65-04-62
Киров (8332)68-02-04
Коломна (4966)23-41-49
Кострома (4942)77-07-48
Краснодар (861)203-40-90
Красноярск (391)204-63-61
Курск (4712)77-13-04
Курган (3522)50-90-47
Липецк (4742)52-20-81

Магнитогорск (3519)55-03-13
Москва (495)268-04-70
Мурманск (8152)59-64-93
Набережные Челны (8552)20-53-41
Нижний Новгород (831)429-08-12
Новокузнецк (3843)20-46-81
Ноябрьск (3496)41-32-12
Новосибирск (383)227-86-73
Омск (3812)21-46-40
Орел (4862)44-53-42
Оренбург (3532)37-68-04
Пенза (8412)22-31-16
Петрозаводск (8142)55-98-37
Псков (8112)59-10-37
Пермь (342)205-81-47

Ростов-на-Дону (863)308-18-15
Рязань (4912)46-61-64
Самара (846)206-03-16
Санкт-Петербург (812)309-46-40
Саратов (845)249-38-78
Севастополь (8692)22-31-93
Саранск (8342)22-96-24
Симферополь (3652)67-13-56
Смоленск (4812)29-41-54
Сочи (862)225-72-31
Ставрополь (8652)20-65-13
Сургут (3462)77-98-35
Сыктывкар (8212)25-95-17
Тамбов (4752)50-40-97
Тверь (4822)63-31-35

Тольятти (8482)63-91-07
Томск (3822)98-41-53
Тула (4872)33-79-87
Тюмень (3452)66-21-18
Ульяновск (8422)24-23-59
Улан-Удэ (3012)59-97-51
Уфа (347)229-48-12
Хабаровск (4212)92-98-04
Чебоксары (8352)28-53-07
Челябинск (351)202-03-61
Череповец (8202)49-02-64
Чита (3022)38-34-83
Якутск (4112)23-90-97
Ярославль (4852)69-52-93

Россия +7(495)268-04-70

Казахстан +7(7172)727-132

Киргизия +996(312)96-26-47

эл.почта: ehr@nt-rt.ru || сайт: <https://endcounters.nt-rt.ru/>

Technical Information

Cubemass DCI

Coriolis flowmeter



The ultra-compact sensor for smallest quantities with seamless system integration

Application

- Measuring principle operates independently of physical fluid properties such as viscosity or density
- Measuring accurately smallest quantities of liquids and gases; ideal for skid integration

Device properties

- Nominal diameter: DN 1 to 6 ($\frac{1}{24}$ to $\frac{1}{4}$ ")
- Process pressure up to 400 bar (5800 psi)
- Medium temperature up to +200 °C (+392 °F)
- Device in compact or remote version
- Flexible outputs
- Modbus RS485

Your benefits

- Reduced installation cost – compact single-tube design
- Fewer process measuring points – multivariable measurement (flow, density, temperature)
- Space-saving installation – no in/outlet run needs
- High flexibility in system integration - wide range of communication interfaces
- Fast commissioning – pre-configured devices
- Automatic recovery of data for servicing

Table of contents

Function and system design	3	Pressure-temperature ratings	15
Measuring principle	3	Rupture disk	16
Measuring system	4	Limiting flow	16
Input	4	Pressure loss	16
Measured variable	4	System pressure	16
Measuring range	4	Mechanical construction	17
Operable flow range	4	Design/dimensions	17
Input signal	4	Weight	25
Output	5	Material	25
Output signal	5	Process connections	26
Signal on alarm	5	Operability	26
Switching output	5	Local display	26
Load	5	Language groups	26
Galvanic isolation	5	Remote operation	26
Power supply	6	Certificates and approvals	27
Terminal assignment	6	CE mark	27
Supply voltage	6	C-Tick symbol	27
Power consumption	6	Ex approval	27
Power supply failure	6	HART certification	27
Electrical connection	7	Modbus certification	27
Electrical connection, Remote version	8	Functional safety	27
Potential equalization	8	Pressure measuring device approval	27
Cable entries	8	Other standards and guidelines	27
Cable specifications	8	Ordering Information	28
Performance characteristics	9	Accessories	28
Reference operating conditions	9	Device-specific accessories	28
Maximum measured error	9	Communication-specific accessories	28
Repeatability	10	Service-specific accessories	29
Response time	10	System components	29
Influence of medium temperature	10	Documentation	30
Influence of medium pressure	10	Registered trademarks	30
Design fundamentals	11		
Installation	11		
Installation instructions	11		
Inlet and outlet runs	11		
Connection cable length	12		
Special installation instructions	12		
Environment	13		
Ambient temperature range	13		
Storage temperature	13		
Degree of protection	13		
Shock resistance	13		
Vibration resistance	13		
CIP cleaning	13		
SIP cleaning	13		
Electromagnetic compatibility (EMC)	13		
Process	14		
Medium temperature range	14		
Secondary containment pressure rating	14		

Function and system design

Measuring principle

The measuring principle is based on the controlled generation of Coriolis forces. These forces are always present when both translational and rotational movements are superimposed.

$$F_C = 2 \cdot \Delta m (v \cdot \omega)$$

F_C = Coriolis force

Δm = moving mass

ω = rotational velocity

v = radial velocity in rotating or oscillating system

The amplitude of the Coriolis force depends on the moving mass Δm , its velocity v in the system, and thus on the mass flow. Instead of a constant angular velocity ω , oscillation occurs.

This causes the measuring tube loop through which the fluid is flowing to oscillate. The Coriolis forces produced at the measuring tube loop cause a phase shift in the oscillations of the tube loop (see illustration):

- If there is zero flow, i.e. when the fluid stands still, the oscillation measured at points A and B has the same phase, and thus there is no phase difference (1).
- Mass flow causes deceleration of the oscillation at the inlet of the tube loop (2) and acceleration at the outlet (3).

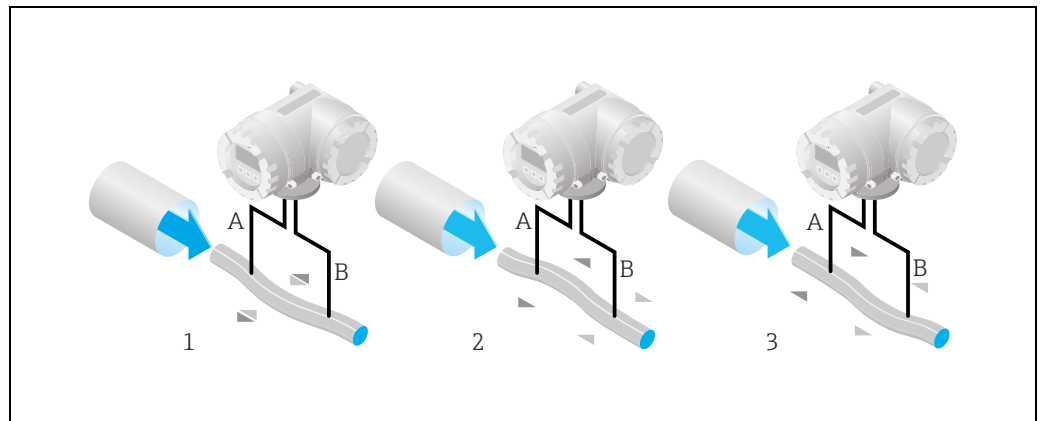

A0003383

The phase difference (A-B) increases with increasing mass flow. Electrodynamical sensors register the tube loop oscillations at the inlet and outlet. Compared to two-tube systems, other design solutions are required in single-tube systems to ensure system balance. In the case of the CNGmass DCI, an internal reference mass is provided for this purpose. The measuring principle operates independently of temperature, pressure, viscosity, conductivity and flow profile.

Density measurement

The measuring tube is continuously excited at its resonance frequency. A change in the mass and thus the density of the oscillating system (comprising the measuring tube loop and fluid) results in a corresponding, automatic adjustment in the oscillation frequency. Resonance frequency is thus a function of fluid density. The microprocessor utilizes this relationship to obtain a density signal.

Temperature measurement

The temperature of the measuring tube loop is determined in order to calculate the compensation factor due to temperature effects. This signal corresponds to the process temperature and is also available as an output.

Measuring system

The measuring system consists of a transmitter and a sensor. Two versions are available:

- Compact version: transmitter and sensor form a mechanical unit.
- Remote version: transmitter and sensor are mounted physically separate from one another.

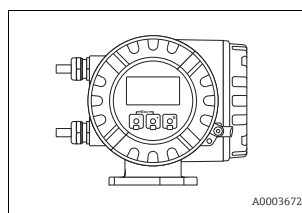
Transmitter

- Four-line liquid crystal display
- Configuration via Touch Control, HART, Modbus RS485, FieldCare
- Application-specific Quick Setup
- Mass flow, volume flow, density and temperature measurement as well as calculated variables (e.g. fluid concentrations)

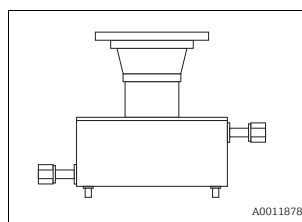
Sensor

- Universal sensor for fluid temperatures up to 200 °C.
- Nominal diameters DN 1 to 6
- Tube material: stainless steel

Input**Measured variable**

- Mass flow (proportional to the phase difference between two sensors mounted on the measuring tube to register a phase shift in the oscillation)
- Volume flow (calculated using mass flow and density)
- Fluid density (proportional to the resonance frequency of the measuring tube)
- Fluid temperature (measured with temperature sensors)

Measuring range**Measuring ranges for liquids**

DN		Range for full scale values (liquids) $\dot{m}_{\min(F)}$ to $\dot{m}_{\max(F)}$	
[mm]	[in]	[kg/h]	[lb/min]
1	1/24"	0 to 20.00	0 to 0.735
2	1/12"	0 to 100.0	0 to 3.675
4	1/8"	0 to 450.0	0 to 16.54
6	1/4"	0 to 1000	0 to 36.75

Operable flow range

1:100

Input signal**Status input (auxiliary input)**

U = 3 to 30 V DC, $R_i = 5 \text{ k}\Omega$, galvanically isolated.

Switching level: 3 to 30 V DC, polarity-independent.

Configurable for: totalizer reset, positive zero return, error message reset, start zero point adjustment.

Output

Output signal	<p>Current output</p> <p>Active/passive selectable, galvanically isolated, time constant selectable (0.05 to 100 s), full scale value selectable, temperature coefficient: typically 0.005% o.r. / °C, resolution: 0.5 µA</p> <ul style="list-style-type: none"> ■ Active: 0/4 to 20 mA, $R_L < 700 \Omega$, $R_L \geq 250 \Omega$ (HART) ■ Passive: 4 to 20 mA; supply voltage V_S: 18 to 30 V DC; $R_i \geq 150 \Omega$ <p>o.r. = of reading</p> <p>Pulse/frequency output</p> <p>Active/passive selectable, galvanically isolated</p> <ul style="list-style-type: none"> ■ Active: 24 V DC, 25 mA (max. 250 mA during 20 ms), $R_L > 100 \Omega$ ■ Passive: open collector, 30 V DC, 250 mA ■ Frequency output: full scale frequency 2 to 10000 Hz ($f_{max} = 12500$ Hz), on/off ratio 1:1, pulse width max. 2 s ■ Pulse output: pulse value and pulse polarity selectable, pulse width configurable (0.05 to 2000 ms) <p>Modbus RS485</p> <ul style="list-style-type: none"> ■ Modbus device type: slave ■ Address range: 1 to 247 ■ Supported function codes: 03, 04, 06, 08, 16, 23 ■ Broadcast: supported with the function codes 06, 16, 23 ■ Physical interface: <ul style="list-style-type: none"> RS485 in accordance with EIA/TIA-485 standard ■ Supported baud rate: 1200, 2400, 4800, 9600, 19200, 38400, 57600, 115200 Baud ■ Transmission mode: <ul style="list-style-type: none"> RTU or ASCII ■ Response times: <ul style="list-style-type: none"> Direct data access = typically 25 to 50 ms Auto-scan buffer (data range) = typically 3 to 5 ms ■ Possible output combinations → Operating Instructions
Signal on alarm	<p>Current output</p> <p>Failsafe mode selectable (for example, according to NAMUR Recommendation NE 43)</p> <p>Pulse/frequency output</p> <p>Failsafe mode selectable</p> <p>Relay output</p> <p>De-energized in the event of fault or power supply failure</p> <p>Modbus RS485</p> <p>If an error occurs, the value NaN (not a number) is output for the process variables.</p>
Switching output	<p>Relay output</p> <p>Normally closed (NC or break) or normally open (NO or make) contacts available (factory setting: relay 1 = normally open), max. 30 V / 0.5 A AC; 60 V / 0.1 A DC, galvanically isolated.</p>
Load	→ "Output signal"
Galvanic isolation	All circuits for inputs, outputs, and power supply are galvanically isolated from each other.

Power supply

Terminal assignment

Electrical values for inputs/outputs → Operating Instructions

Order characteristic for "inputs/outputs"	Terminal No. (inputs/outputs)			
	20 (+) / 21 (-)	22 (+) / 23 (-)	24 (+) / 25 (-)	26 (+) / 27 (-)
Fixed communication boards (permanent assignment)				
S	-	-	Frequency output, Ex i, passive	Current output, Ex i, active, HART
T	-	-	Frequency output, Ex i, passive	Current output, Ex i, passive, HART
Q	-	-	Status input	Modbus RS485
Flexible communication boards				
D	Status input	Relay output	Frequency output	Current output, HART
M	Status input	Frequency output 2	Frequency output 1	Current output, HART
N	Current output	Frequency output	Status input	Modbus RS485
1	Relay output	Frequency output 2	Frequency output 1	Current output, HART
2	Relay output	Current output 2	Frequency output	Current output 1, HART
7	Relay output 2	Relay output 1	Status input	Modbus RS485

Supply voltage

85 to 260 V AC, 45 to 65 Hz
 20 to 55 V AC, 45 to 65 Hz
 16 to 62 V DC

Power consumption

AC: < 15 VA (including sensor)
 DC: < 15 W (including sensor)

Switch-on current

- Max. 13.5 A (< 50 ms) at 24 V DC
- Max. 3 A (< 5 ms) at 260 V AC

Power supply failure

Lasting min. 1 power cycle:

- EEPROM or HistoROM T-DAT saves measuring system data if power supply fails.
- HistoROM/S-DAT: exchangeable data storage chip which stores the data of the sensor (nominal diameter, serial number, calibration factor, zero point etc.)

Electrical connection

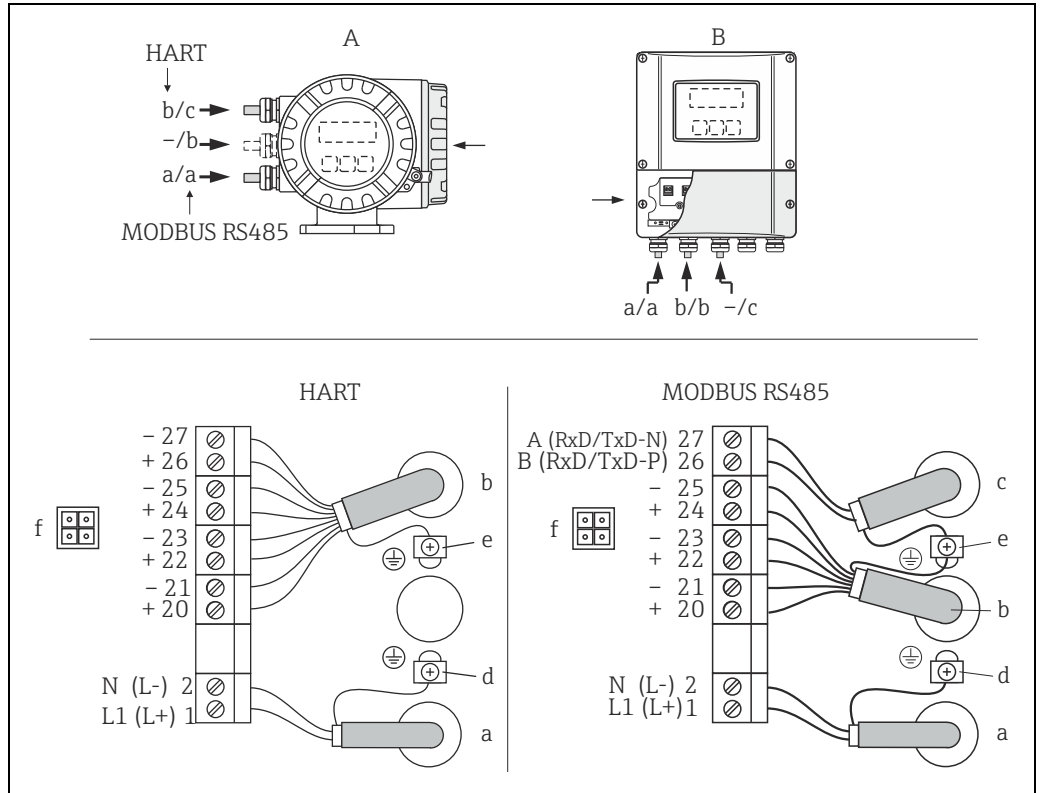

A0012023

Connecting the transmitter, cable cross-section: max. 2.5 mm² (14 AWG)

- A View A (field housing)
- B View B (wall-mount housing)

- a Cable for power supply: 85 to 260 V AC, 20 to 55 V AC, 16 to 62 V DC
 - Terminal No. 1: L1 for AC, L+ for DC
 - Terminal No. 2: NN for AC, L- for DC
- b Signal cable: Terminal assignment → 6
- c Fieldbus cable
 - Terminal No. 26: B (RxD/TxD-P)
 - Terminal No. 27: A (RxD/TxD-N)
- d Ground terminal for protective ground
- e Ground terminal for signal cable shield/ fieldbus cable shield
- Please note:
 - shielding and grounding of fieldbus cable → Operating Instructions
 - that the stripped and twisted lengths of cable shield to the ground terminal are as short as possible
- f Service adapter for connecting service interface FXA193 (FieldCare)

Electrical connection, Remote version

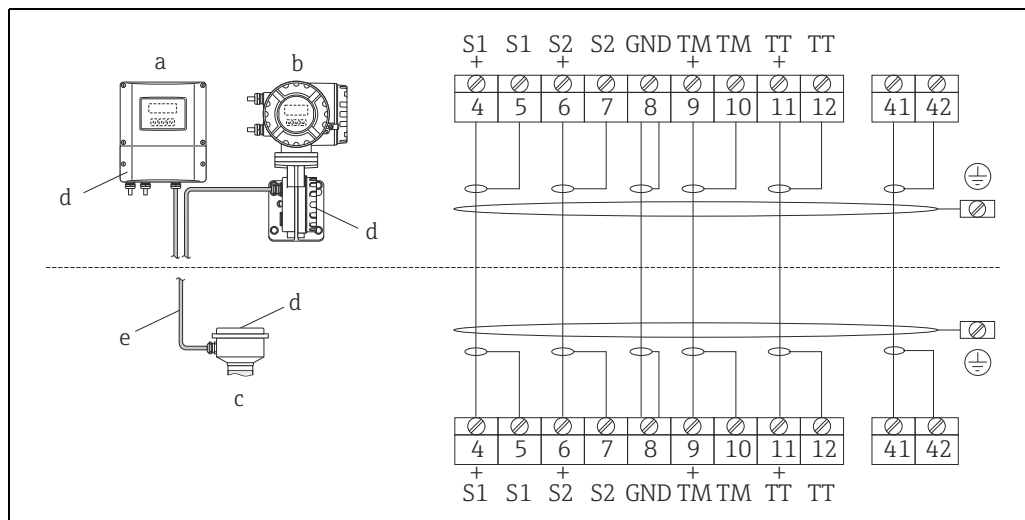

Connecting the remote version

- a Transmitter wall-mount housing: non-hazardous area → separate documentation
 b Transmitter wall-mount housing: ATEX II2G / Zone 1 / NEC/CEC → separate Ex documentation
 c Sensor connection housing
 d Cover of connection compartment or connection housing
 e Connecting cable

Terminal No.: 4/5 = gray; 6/7 = green; 8 = yellow; 9/10 = pink; 1¹/₂ = white; 41/42 = brown

Potential equalization

No measures necessary.

For explosion-protected equipment → separate Ex-documentation supplied

Cable entries

Power supply and signal cables (inputs/outputs):

- Cable entry M20 × 1.5 (8 to 12 mm / 0.31 to 0.47")
- Threads for cable entries, 1/2" NPT, G 1/2"

Connecting cable for remote version:

- Cable entry M20 × 1.5 (8 to 12 mm / 0.31 to 0.47")
- Threads for cable entries, 1/2" NPT, G 1/2"

Cable specifications

Any suitable cable with a temperature specification of at least 20 °C (68 °F) higher than the ambient temperature of the application. We recommend the use of a cable with a temperature specification of +80 °C (+176 °F).

Remote version:

- 6 × 0.38 mm² (20 AWG) PVC cable with common shield and individually shielded cores
- Conductor resistance: ≤ 50 Ω/km (≤ 0.015 Ω/ft)
- Capacitance core/shield: ≤ 140 pF/m (≤ 42.7 pF/ft)
- Cable length: max. 20 m (65.6 ft)
- Permanent operating temperature: max. +105 °C (+221 °F)



Note!

The cable must be installed securely, to prevent movement.

Modbus RS485 (cable type A):

- Characteristic impedance: 135 to 165 Ω at a measuring frequency of 3 to 20 MHz
- Cable capacity: < 30 pF/m (< 9.2 pF/ft)
- Core cross-section: > 0.34 mm² (AWG 22)
- Cable type: twisted pairs
- Loop-resistance: ≤ 110 Ω/km (≤ 0.034 Ω/ft)
- Signal damping: max. 9 dB along the entire length of the cable cross-section
- Shield: Copper braided shielding or braided shielding and foil shielding

Performance characteristics

Reference operating conditions

- Error limits following ISO 11631
- Water, typically +15 to +45 °C (+59 to +113 °F); 2 to 6 bar (29 to 87 psi)
- Specification as per calibration protocol ± 5 °C (± 9 °F) and ± 2 bar (± 30 psi)
- Data on the measured error based on accredited calibration rigs traced back to ISO 17025

To obtain measured errors, use the Applicator sizing tool *Applicator*: →  29.

Maximum measured error

Design fundamentals →  11

o.r. = of reading; $1 \text{ g/cm}^3 = 1 \text{ kg/l}$; T = fluid temperature

Base accuracy

Mass flow and volume flow (liquids)

- $\pm 0.10\%$ o.r. (mass flow)
- $\pm 0.10\%$ o.r. (volume flow)

Mass flow (gases)

- $\pm 0.5\%$ o.r.

Density (liquids)

- Reference conditions: $\pm 0.0005 \text{ g/cm}^3$
- Standard density calibrations: $\pm 0.02 \text{ g/cm}^3$ (valid over the entire measuring range of the sensor →  15)
- Wide-range density specification: $\pm 0.002 \text{ g/cm}^3$ (valid range for special density calibration: +5 to +80 °C (+41 to +176 °F))

Temperature

$\pm 0.5 \text{ °C} \pm 0.005 \cdot T \text{ °C}$ ($\pm 1.0 \text{ °F} \pm 0.003 \cdot (T - 32) \text{ °F}$)

Zero point stability

DN		Zero point stability	
[mm]	[in]	[kg/h]	[lb/min]
1	$\frac{1}{24}$ "	0.0008	0.00003
2	$\frac{1}{12}$ "	0.002	0.00007
4	$\frac{1}{8}$ "	0.014	0.0005
6	$\frac{1}{4}$ "	0.02	0.0007

Flow values

Flow values as turndown parameter depending on nominal diameter.

SI units

DN [mm]	1:1 [kg/h]	1:10 [kg/h]	1:20 [kg/h]	1:50 [kg/h]	1:100 [kg/h]	1:500 [kg/h]
1	20.00	2.000	1.000	0.400	0.200	0.040
2	100.0	10.00	5.000	2.000	1.000	0.200
4	450.0	45.00	22.50	9.000	4.500	0.900
6	1000	100.0	50.00	20.00	10.00	2.000

US units

DN [in]	1:1 [lb/min]	1:10 [lb/min]	1:20 [lb/min]	1:50 [lb/min]	1:100 [lb/min]	1:500 [lb/min]
1/24"	0.735	0.074	0.037	0.015	0.007	0.001
1/12"	3.675	0.368	0.184	0.074	0.037	0.007
1/8"	16.54	1.654	0.827	0.330	0.165	0.033
1/4"	36.75	3.675	1.838	0.735	0.368	0.074

Accuracy of outputs

o.r. = of reading; o.f.s. = of full scale value

The output accuracy must be factored into the measured error if analog outputs are used, but can be ignored for fieldbus outputs (e.g. Modbus RS485).

*Current output*Accuracy: Max. $\pm 0.05\%$ o.f.s. or $\pm 5\ \mu\text{A}$ *Pulse/frequency output*Accuracy: Max. $\pm 50\%$ ppm o.r.**Repeatability**

Design fundamentals → 11

o.r. = of reading; $1\ \text{g/cm}^3 = 1\ \text{kg/l}$; T = fluid temperature**Base repeatability****Mass flow and volume flow (liquids)**

- $\pm 0.05\%$ o.r. (mass flow)
- $\pm 0.05\%$ o.r. (volume flow)

Mass flow (gases)

- $\pm 0.25\%$ o.r. (mass flow)

Density (liquids)

- $\pm 0.00025\ \text{g/cm}^3$

Temperature $\pm 0.25\ ^\circ\text{C} \pm 0.0025 \cdot T\ ^\circ\text{C}$ ($\pm 0.45\ ^\circ\text{F} \pm 0.0015 \cdot (T - 32)\ ^\circ\text{F}$)**Response time**

- The response time depends on the configuration (damping).
- Response time in the event of erratic changes in the measured variable (only mass flow): after 100 ms 95 % of the full scale value.

Influence of medium temperatureWhen there is a difference between the temperature for zero point adjustment and the process temperature, the typical measured error is $\pm 0.0002\%$ of the full scale value / $^\circ\text{C}$ ($\pm 0.0001\%$ of the full scale value / $^\circ\text{F}$).**Influence of medium pressure**

The tables below shows the effect on accuracy of mass flow due to a difference between calibration pressure and process pressure.

DN		Medium pressure	
[mm]	[in]	[% o.r./bar]	[% o.r./psi]
1	1/24"	-0.001	-0.00007
2	1/12"	0	0
4	1/8"	-0.005	-0.0004
6	1/4"	-0.003	-0.0002

Design fundamentals

o.r. = of reading
 BaseAccu = base accuracy in % o.r.
 BaseRepeat = base repeatability in % o.r.
 MeasValue = measured value (in flow units consistent with the zero point stability value → 9)
 ZeroPoint = zero point stability

Calculation of the maximum measured error depending on flowrate

Flowrate (in flow units consistent with the zero point stability value → 9)	Maximum measured error in % o.r.
$\geq \frac{\text{ZeroPoint}}{\text{BaseAccu}} \cdot 100$ <small>A0021332</small>	$\pm \text{BaseAccu}$ <small>A0021339</small>
$< \frac{\text{ZeroPoint}}{\text{BaseAccu}} \cdot 100$ <small>A0021333</small>	$\pm \frac{\text{ZeroPoint}}{\text{MeasValue}} \cdot 100$ <small>A0021334</small>

Calculation of the repeatability depending on flowrate

Flowrate (in flow units consistent with the zero point stability value → 9)	Repeatability in % o.r.
$\geq \frac{1/2 \cdot \text{ZeroPoint}}{\text{BaseRepeat}} \cdot 100$ <small>A0021335</small>	$\pm \text{BaseRepeat}$ <small>A0021340</small>
$< \frac{1/2 \cdot \text{ZeroPoint}}{\text{BaseRepeat}} \cdot 100$ <small>A0021336</small>	$\pm 1/2 \cdot \frac{\text{ZeroPoint}}{\text{MeasValue}} \cdot 100$ <small>A0021337</small>

Example for maximum measured error

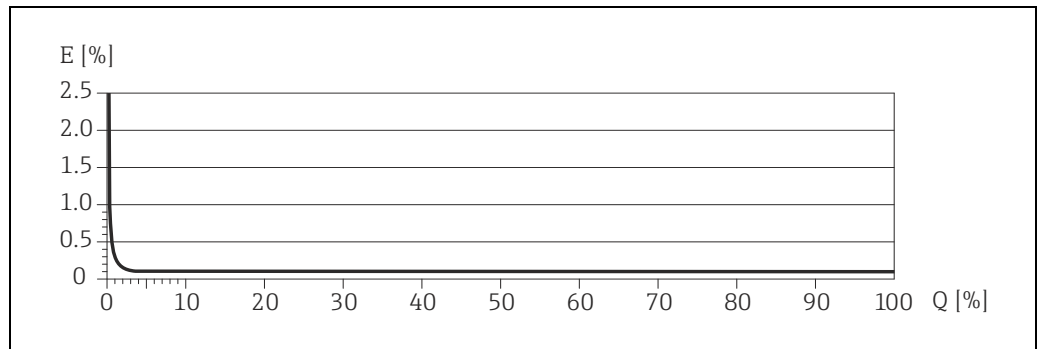

E = Error: Maximum measured error as % o.r.

Q = Flow rate as %

Installation

Installation instructions

- Note the following points:
- The measuring device is designed for mounting on tabletops, walls or pipes.
 - The high oscillation frequency of the measuring tubes ensures that the correct operation of the measuring system is not influenced by pipe vibrations.
 - No special precautions need to be taken for fittings which create turbulence (valves, elbows, T-pieces etc.) as long as no cavitation occurs.

Inlet and outlet runs

There are no installation requirements regarding inlet and outlet runs. If possible, mount the sensor upstream of fittings such as valves, T-pieces, elbows etc.

Connection cable length Max. 20 m (max. 65 ft)

Special installation instructions

Rotating the transmitter housing

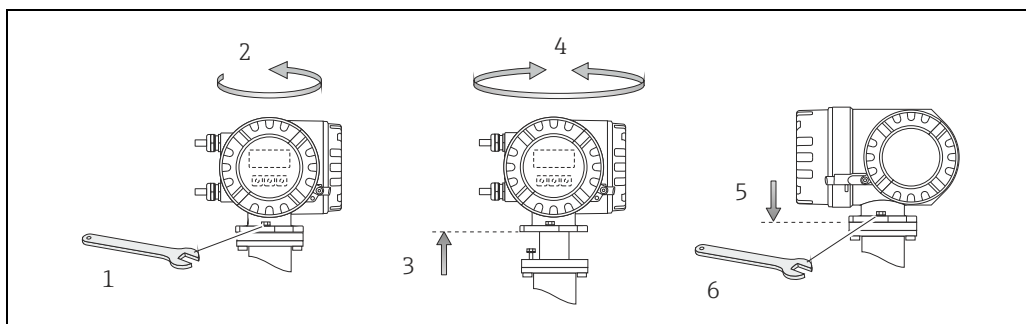

A0004302

Rotating the transmitter housing

Rupture disk

Make sure that the function and operation of the rupture disk is not impeded through the installation of the device. The position of the rupture disk is indicated on a sticker beside it. For additional information that is relevant to the process (→ 16).

The existing connecting nozzles are not intended for the purpose of rinsing or pressure monitoring, but instead serve as the mounting location for the rupture disk.

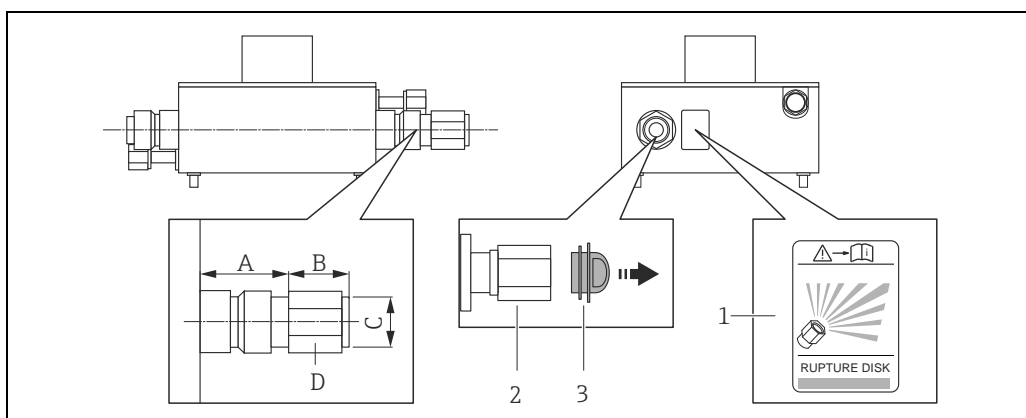

A0019637

- 1 Rupture disk label
- 2 Rupture disk with 1/2" NPT internal thread with 1" width across flat
- 3 Transport protection

Dimensions in SI units

DN	A	B	C	D
1 to 6	33	Approx. 42	1/2" NPT	AF 1"

All dimensions in [mm]

Dimensions in US units

DN	A	B	C	D
1/24 to 1/4"	1.3	Approx. 1.65	1/2" NPT	AF 1"

All dimensions in [in]

Zero point adjustment

All measuring devices are calibrated using state-of-the-art technology. Calibration takes place under reference conditions (→ 9). Therefore, a zero point adjustment is generally **not** required.

If a zero point adjustment is desired, please note the following points before performing one:

- Adjustment can only be performed under stable pressure conditions.
- The zero point adjustment takes place at zero flow. This can be achieved, for example, with shutoff valves upstream and/or downstream of the sensor or by using existing valves and gates.
 - Normal operation → valves 1 and 2 open
 - Zero point adjustment *with* process pressure → Valve 1 open / valve 2 closed
 - Zero point adjustment *without* process pressure → Valve 1 closed / valve 2 open
- A zero point adjustment is **not** possible if an error message is present.

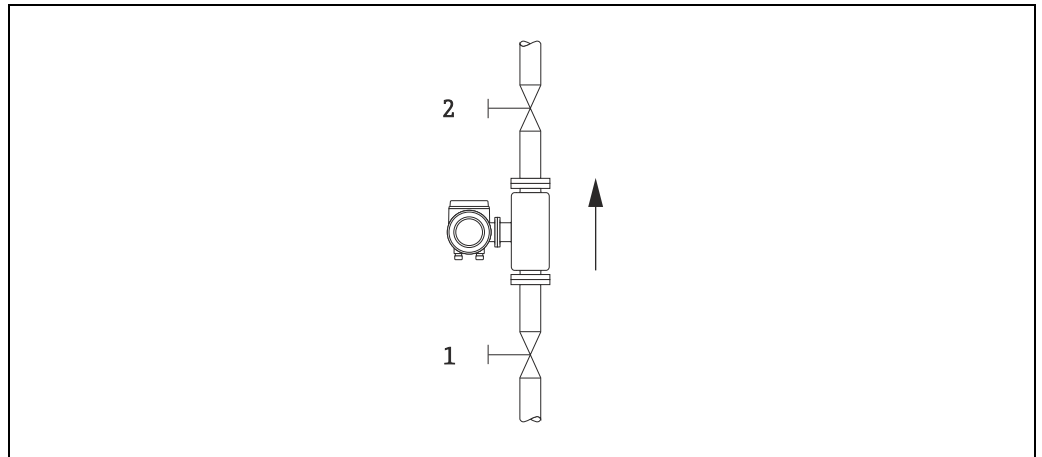

Zero point adjustment and shutoff valves

A0003601

Environment

Ambient temperature range	Sensor and transmitter: <ul style="list-style-type: none"> ▪ Standard: -20 to +60 °C (-4 to +140 °F) ▪ Optional: -40 to +60 °C (-40 to +140 °F) ▪ Install the device in a shady location. Avoid direct sunlight, particularly in warm climatic regions. ▪ At ambient temperatures below -20 °C (-4 °F), the readability of the display may be impaired.
Storage temperature	-40 to +80 °C (-40 to +175 °F), preferably at +20 °C (+68 °F)
Degree of protection	Standard: IP 67 (NEMA 4X) for transmitter and sensor
Shock resistance	According to IEC/EN 60068-2-31
Vibration resistance	Acceleration up to 1 g, 10 to 150 Hz, following IEC/EN 60068-2-6
CIP cleaning	Yes
SIP cleaning	Yes
Electromagnetic compatibility (EMC)	As per IEC/EN 61326 and NAMUR Recommendation NE 21

Process

Medium temperature range

Sensor

- -50 to +200 °C (-58 to +392 °F)

Seals

- Only for mounting kits with threaded connections:
 - Viton: -15 to 200 °C (-5 to +392 °F)
 - EPDM: -40 to +160 °C (-40 to +320 °F)
 - Silicone: -60 to +200 °C (-76 to +392 °F)
 - Kalrez: -20 to +275 °C (-4 to +527 °F)

Secondary containment pressure rating

The sensor housing is filled with dry nitrogen and protects the electronics and mechanics inside.

The following secondary containment pressure rating is only valid for a fully welded sensor housing and/or a device equipped with closed purge connections (never opened, as delivered).

DN		Secondary containment rating (designed with a safety factor ≥ 4)		Burst pressure of secondary containment	
[mm]	[in]	[bar]	[psi]	[bar]	[psi]
1	1/24"	40	580	190	2780
2	1/12"	40	580	190	2780
4	1/8"	40	580	190	2780
6	1/4"	40	580	190	2780



Note!

In case a danger of measuring tube failure exists due to process characteristics, e.g. with corrosive process fluids, we recommend the use of sensors whose secondary containment is equipped with special pressure monitoring connections (ordering option). With the help of these connections, fluid collected in the secondary containment in the event of tube failure can be bled off. This is especially important in high pressure gas applications. These connections can also be used for gas circulation and/or gas detection (dimensions → 25).

Do not open the purge connections unless the containment can be filled immediately with a dry inert gas. Use only low gauge pressure to purge. Maximum pressure: 5 bar (72.5 psi).

If a device fitted with purge connections is connected to the purge system, the maximum nominal pressure is determined by the purge system itself or by the device, depending on which component has the lower nominal pressure. If, on the other hand, the device is fitted with a rupture disk, the rupture disk is decisive for the maximum nominal pressure (→ 16).

Pressure-temperature ratings

The following pressure-temperature ratings relate to the entire measuring device and not just to the process connection.

4-VCO-4 coupling (welded, DN 1 to 4)

8-VCO-4 coupling (welded, DN 6)

Connection material: 1.4539 (904L)

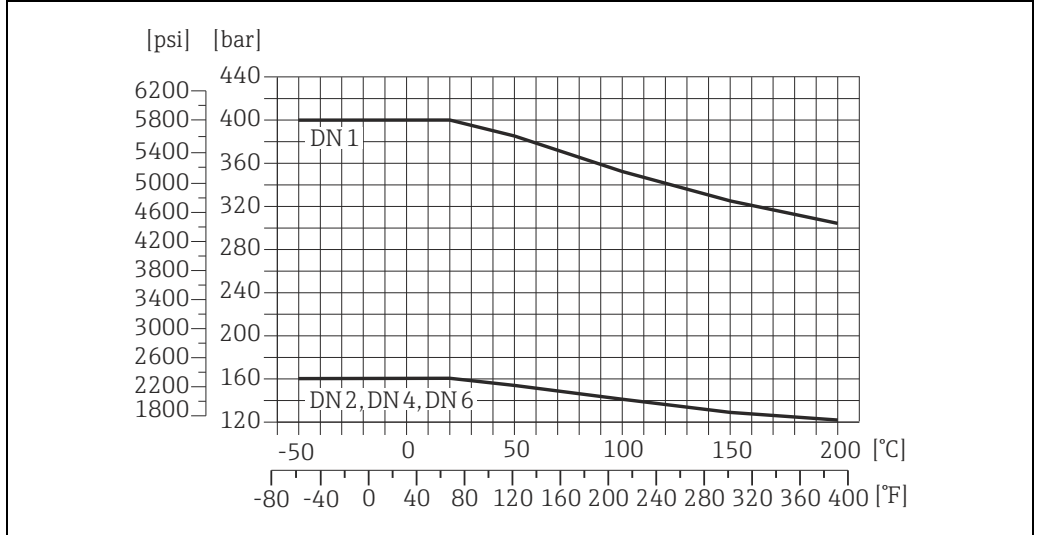

A0021001-EN

VCO coupling with mounting kit: Flange according to EN 1092-1 (DIN 2501)

Wetted parts (flange, measuring tube): 1.4539 (904L)

Loose flanges (not wetted): 1.4404 (316/316L)

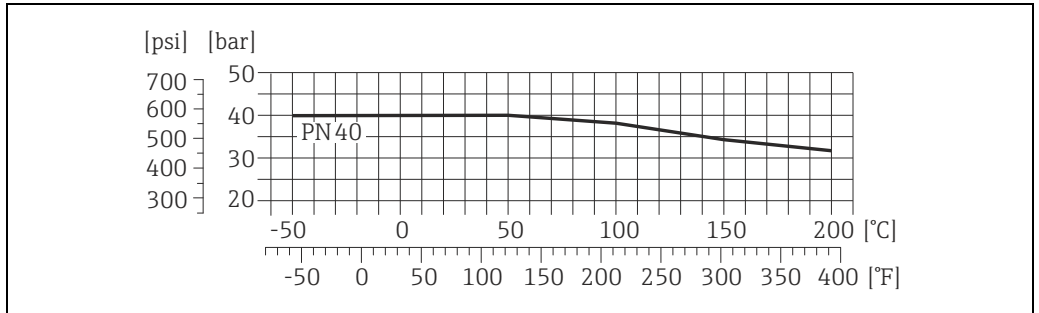

A0021002-EN

VCO coupling with mounting kit: Flange according to ASME B16.5

Wetted parts (flange, measuring tube): 1.4539 (904L)

Loose flanges (not wetted): 1.4404 (316/316L)

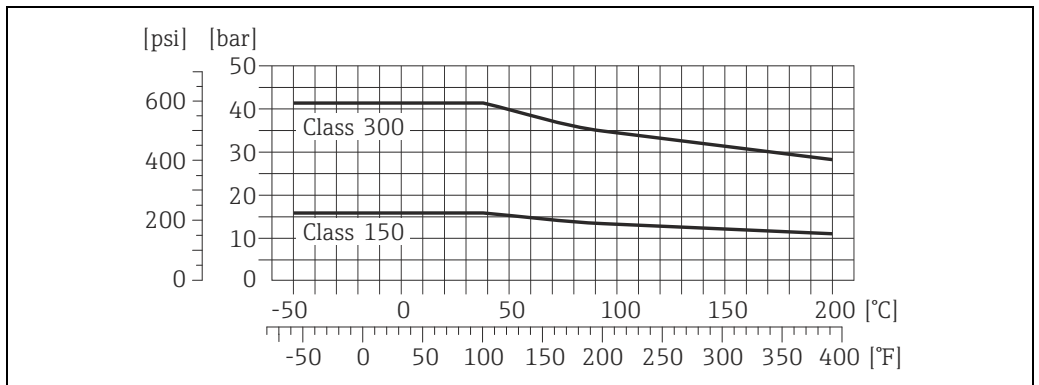

A0020920-EN

VCO coupling with mounting kit: JIS B2220, flange

Wetted parts (flange, measuring tube): 1.4539 (904L)

Loose flanges (not wetted): 1.4404 (316/316L)

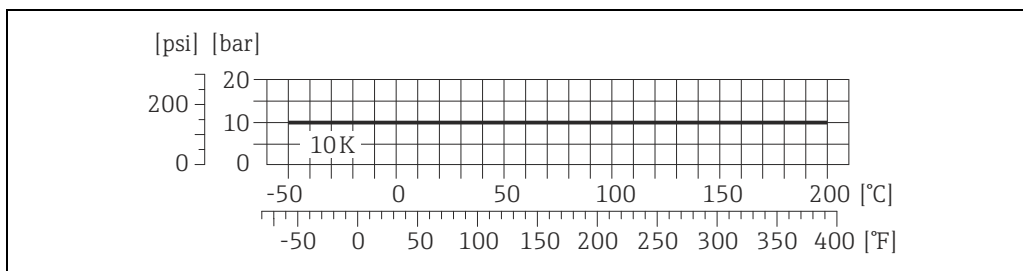

A0021003-EN

4-VCO-4 coupling with mounting kit: NPTF threaded adapter, 1/4" (DN 1 to 4)**4-VCO-8 coupling with mounting kit: NPTF threaded adapter, 1/2" (DN 6)**

Connection material: 1.4539 (904L)

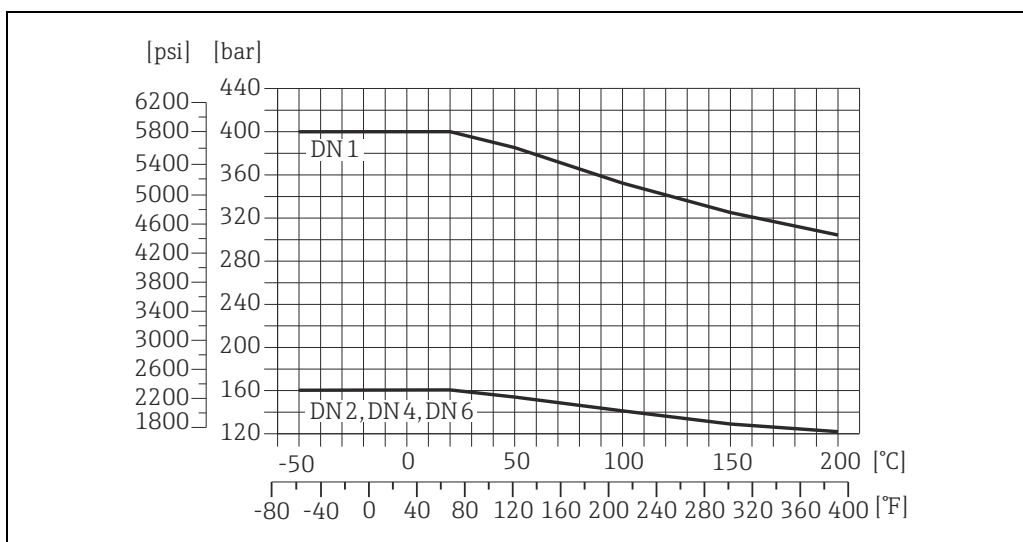

A0021001-EN

Rupture disk

To increase the level of safety, a device version with a rupture disk with a triggering pressure of 10 to 15 bar (145 to 217.5 psi) can be used. Special mounting instructions: (→ 12).

Limiting flow

→ 4, "Measuring range"

Pressure loss

To calculate the pressure loss, use the *Applicator* sizing tool (→ 29).

System pressure

It is important to ensure that cavitation does not occur as it could influence the oscillation of the measuring tube. No special measures need to be taken for fluids which have properties similar to water under normal conditions.

In the case of liquids with a low boiling point (hydrocarbons, solvents, liquefied gases) or in suction lines, it is important to ensure that pressure does not drop below the vapour pressure and that the liquid does not start to boil. It is also important to ensure that the gases that occur naturally in many liquids do not outgas. Such effects can be prevented when system pressure is sufficiently high.

Consequently, it is generally best to install the sensor:

- On the pump pressure side (no risk of vacuum)
- At the lowest point in a riser

Mechanical construction

Design/dimensions

Field housing compact version (non-hazardous area II2G / zone 1)

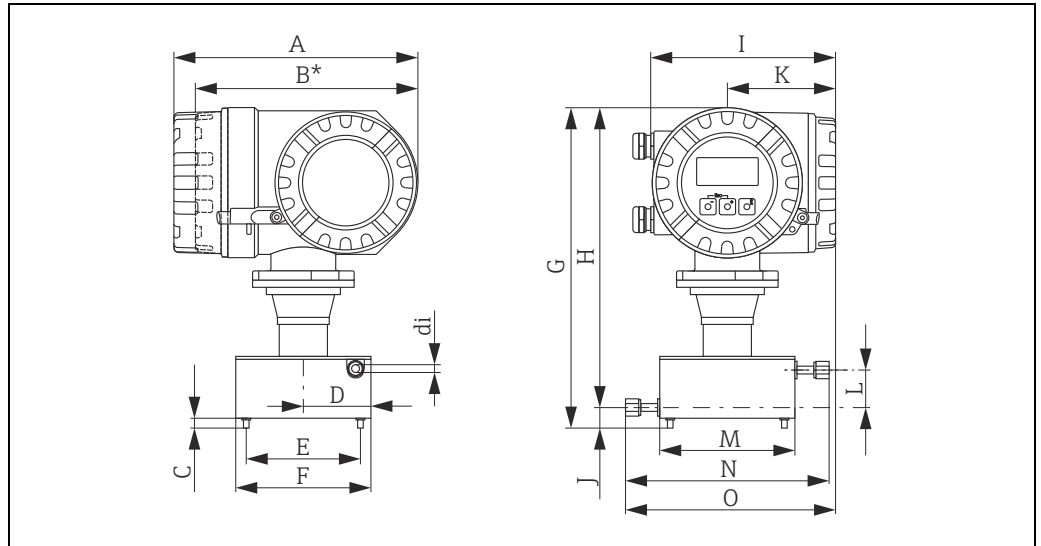

A0011849

Dimensions in SI units

DN	A	B*	C	D	E	F	G	H	I	J	K	L	M	N	O	di
1	227	207	10	40	90	120	291.2	269.3	168	22	100	30	120	175	187.5	1.3
2																2
4																3.9
6																5.35

* Blind version (without local display)

DN 1 to 4: 4-VCO-4

DN 6: 8-VCO-4

All dimensions in [mm]

Dimensions in US units

DN	A	B*	C	D	E	F	G	H	I	J	K	L	M	N	O	di
1/24"	8.94	8.15	0.39	1.57	3.54	4.72	11.5	10.6	6.61	0.87	3.94	1.18	4.72	6.89	7.38	0.05
1/12"																0.08
1/8"																0.15
1/4"																0.21

* Blind version (without local display)

DN 1/24" to 1/8": 4-VCO-4

DN 1/4": 8-VCO-4

All dimensions in [in]

Transmitter, remote version, connection housing (II2G/zone 1)

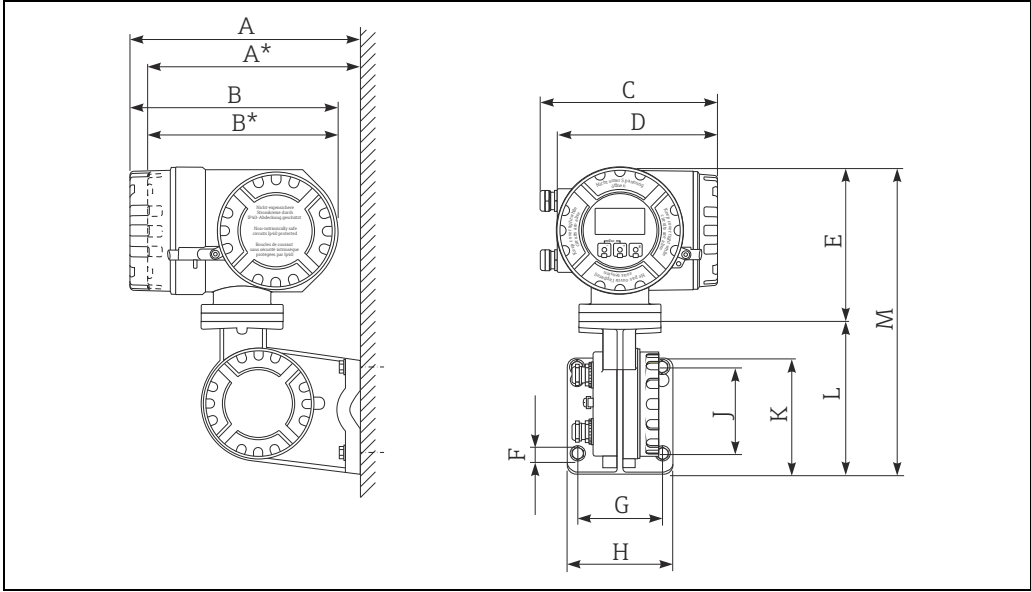

A0006999

Dimensions in SI units

A	A*	B	B*	C	D	E	F	G	H	J	K	L	M
265	242	240	217	206	186	178	∅ 8.6 (M8)	100	130	100	144	170	355

* Blind version (without local display)
All dimensions in [mm]

Dimensions in US units

A	A*	B	B*	C	D	E	F	G	H	J	K	L	M
10.4	9.53	9.45	8.54	8.11	7.32	7.01	∅ 8.6 (M8)	3.94	5.12	3.94	5.67	6.69	13.9

* Blind version (without local display)
All dimensions in [in]

Transmitter, remote version, wall-mount housing (non-hazardous area)

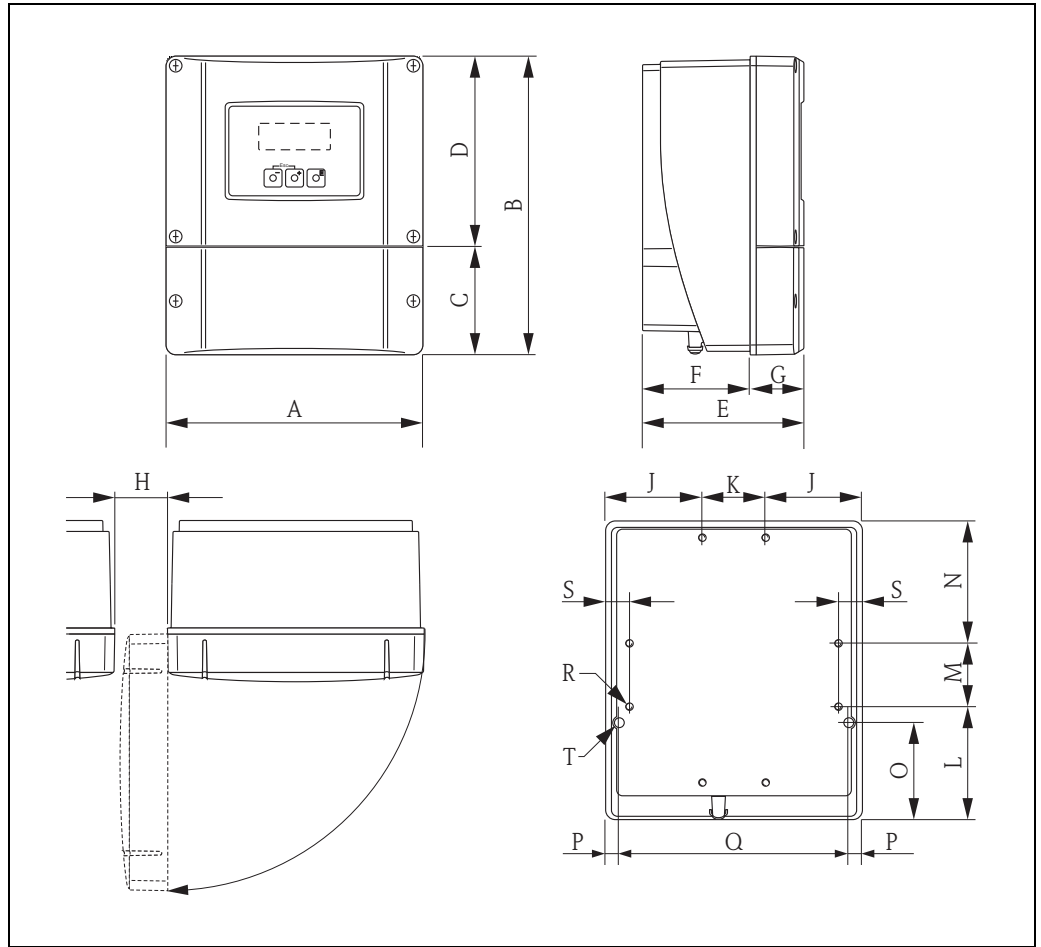

A0001150

Dimensions in SI units

A	B	C	D	E	F	G	H	J	K
215	250	90.5	159.5	135	90	45	> 50	81	53
L	M	N	O	P	Q	R	S	T ¹⁾	
95	53	102	81.5	11.5	192	8 × M5	20	2 × Ø 6.5	

¹⁾ Securing screw for wall mounting: M6 (screw head max. 10.5 mm)
All dimensions in [mm]

Dimensions in US units

A	B	C	D	E	F	G	H	J	K
8.46	9.84	3.56	6.27	5.31	3.54	1.77	> 1.97	3.18	2.08
L	M	N	O	P	Q	R	S	T ¹⁾	
3.74	2.08	4.01	3.20	0.45	7.55	8 × M5	0.79	2 × Ø 0.26	

¹⁾ Securing screw for wall mounting: M6 (screw head max. 0.41")
All dimensions in [in]

Sensor remote version, connection housing

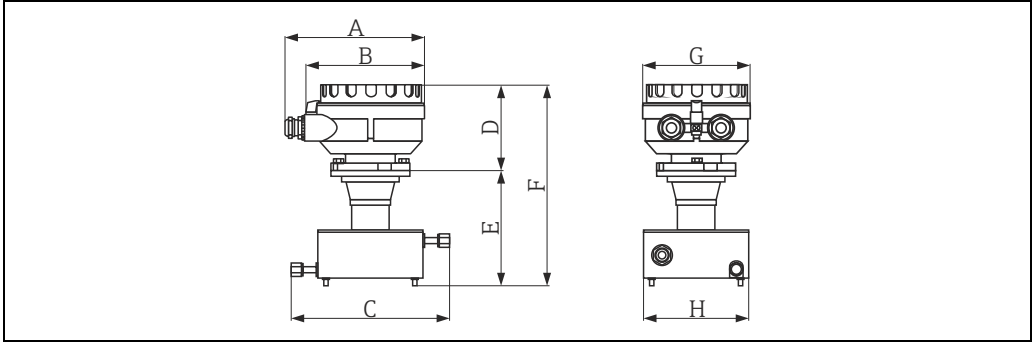

A0012360

Dimensions in SI units

DN	A	B	C	D	E	F	G	H
1 to 6	163	143	175	102	133	235	129	120

All dimensions in [mm]

Dimensions in US units

DN	A	B	C	D	E	F	G	H
1/24 to 1/4"	6.42	5.63	6.89	4.02	5.24	9.25	5.08	4.72

All dimensions in [in]

Process connections in SI units

4-VCO-4 coupling (welded, DN 1 to 4)
 8-VCO-4 coupling (welded, DN 6)

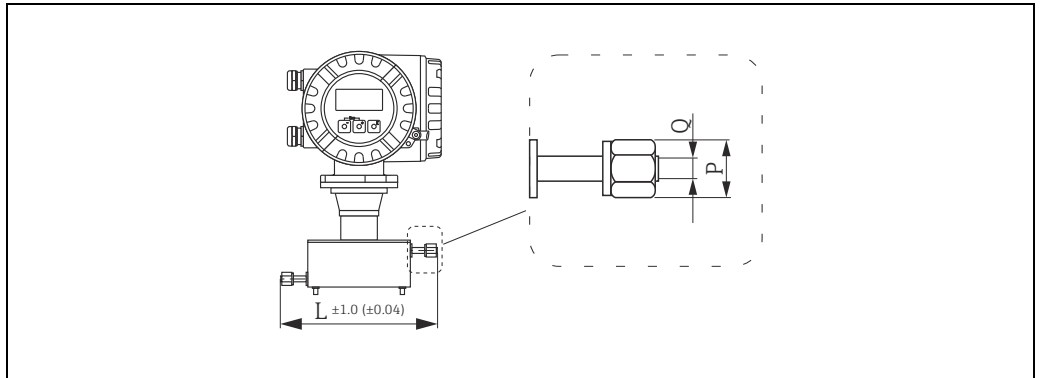

A0012329

Engineering unit mm (in)

4-VCO-4 coupling (welded, DN 1 to 4): 1.4539 (904L)			
Order code for "process connection", option A			
8-VCO-4 coupling (welded, DN 6): 1.4539 (904L)			
Order code for "process connection", option B			
DN	L	P	Q
1 to 4	175	AF 11/16"	12.5
6	175	AF 1"	20

All dimensions in [mm]

4-VCO-4 coupling with mounting kit: NPTF threaded adapter, ¼" (DN 1 to 4)
 8-VCO-4 coupling with mounting kit: NPTF threaded adapter, ½" (DN 6)

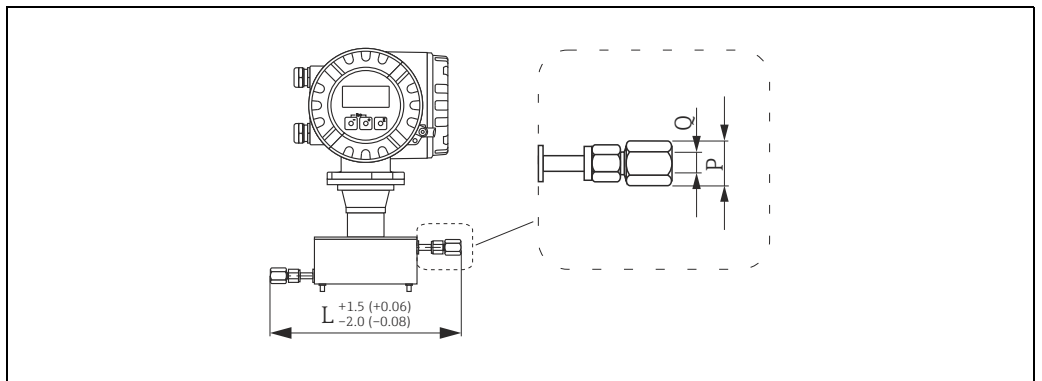

A0012332

Engineering unit mm (in)

4-VCO-4 coupling with mounting kit: NPTF threaded adapter, ¼": 1.4539 (904L)			
DN	L	P	Q
1 to 4	246	AF ¾"	¼" NPTF
6	246	AF 1 1/16"	½" NPTF

All dimensions in [mm]

4-VCO-4 / 8-VCO-4 coupling with mounting kit: Flange according to EN1092-1 (DIN 2501)

4-VCO-4 / 8-VCO-4 coupling with mounting kit: ½" flange according to ASME B16.5

4-VCO-4 / 8-VCO-4 coupling with mounting kit: JIS B2220, DN 15 flange

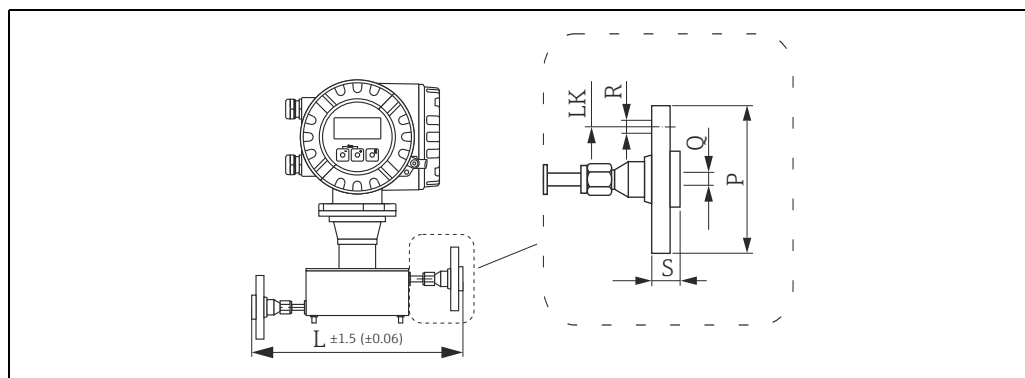

A0012330

Engineering unit mm (in)

4-VCO-4 / 8-VCO-4 coupling with mounting kit: Flange according to EN1092-1 (DIN 2501), PN 40: 1.4539 (904L)

DN	PN	L	P	Q	R	S	LK
1 to 6	40	278	95	17.3	4 × Ø 14	28	65

All dimensions in [mm]

4-VCO-4 / 8-VCO-4 coupling with mounting kit: ½" flange according to ASME B16.5: 1.4539 (904L)

DN	ASME	L	P	Q	R	S	LK
1 to 6	Cl 150	278	88.9	15.7	4 × Ø 15.7	17.7	60.5
1 to 6	Cl 300	278	95.2	15.7	4 × Ø 15.7	20.7	66.5

Loose flanges (not wetted) made from stainless steel 1.4404 (316/316L)

All dimensions in [mm]

4-VCO-4 / 8-VCO-4 coupling with mounting kit: JIS B2220, DN 15 flange: 1.4539 (904L)

DN	JIS	L	P	Q	R	S	LK
1 to 6	10K	278	95	15	4 × Ø 15	28	70

All dimensions in [mm]

Process connections in US units

4-VCO-4 coupling (welded, DN 1/24 to 1/8")
 8-VCO-4 coupling (welded, DN 1/4")

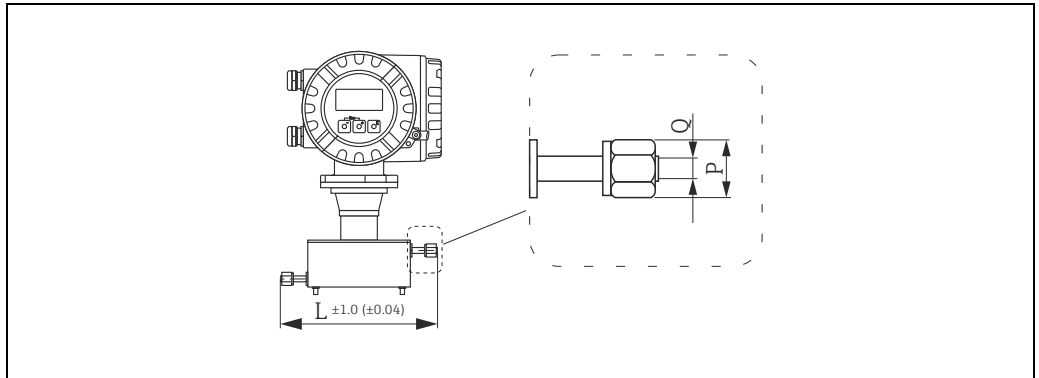

A0012329

Engineering unit mm (in)

4-VCO-4 coupling (welded, DN 1/24 to 1/8"): 1.4539 (904L) Order code for "process connection", option A 8-VCO-4 coupling (welded, DN 1/4"): 1.4539 (904L) Order code for "process connection", option B			
DN	L	P	Q
1/24 to 1/8"	6.89	AF 11/16"	0.49
1/4"	6.89	AF 1"	0.79

All dimensions in [in]

4-VCO-4 coupling with mounting kit: NPTF threaded adapter, 1/4" (DN 1/24 to 1/8")
 8-VCO-4 coupling with mounting kit: NPTF threaded adapter, 1/2" (DN 1/4")

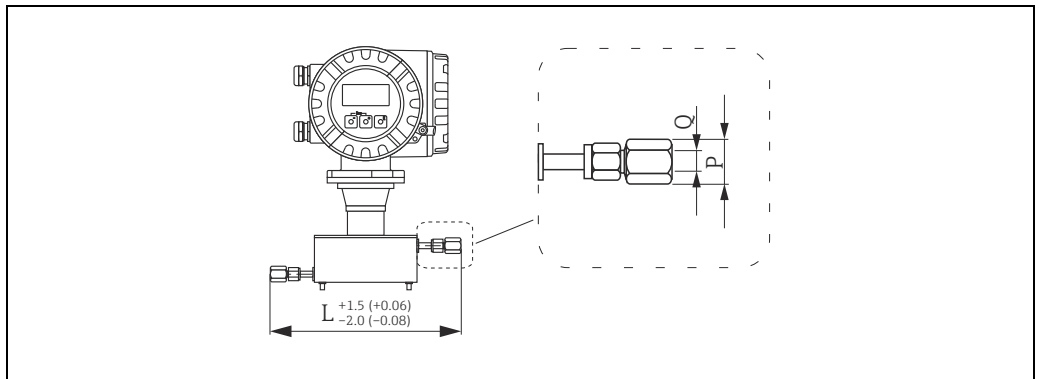

A0012332

Engineering unit mm (in)

8-VCO-4 coupling with mounting kit: NPTF threaded adapter, 1/2": 1.4539 (904L)			
DN	L	P	Q
1/24 to 1/8"	9.69	AF 3/4"	1/4" NPTF
1/4"	9.69	AF 1 1/16"	1/2" NPTF

All dimensions in [in]

4-VCO-4 / 8-VCO-4 coupling with mounting kit: Flange according to EN1092-1 (DIN 2501)

4-VCO-4 / 8-VCO-4 coupling with mounting kit: ½" flange according to ASME B16.5

4-VCO-4 / 8-VCO-4 coupling with mounting kit: JIS B2220, DN 15 flange

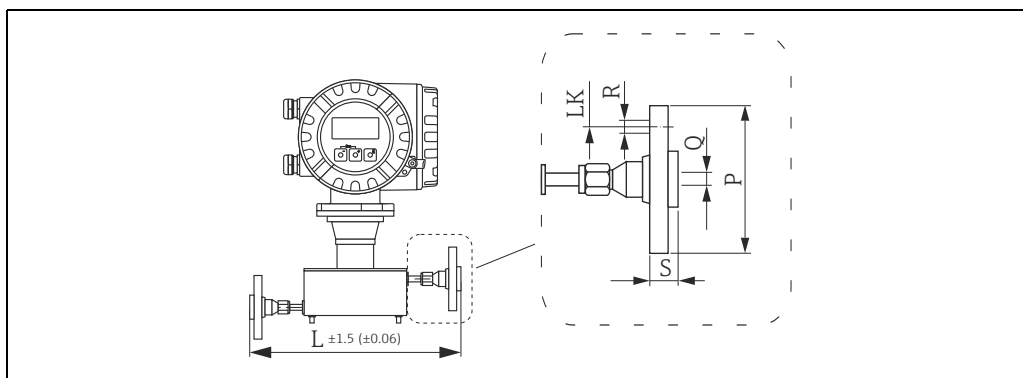

A0012330

Engineering unit mm (in)

4-VCO-4 / 8-VCO-4 coupling with mounting kit: Flange according to EN1092-1 (DIN 2501), PN 40: 1.4539 (904L)

DN	PN	L	P	Q	R	S	LK
½ ₂₄ to ¼"	40	11	3.74	0.68	4 × Ø 0.55	1.10	2.56

All dimensions in [in]

4-VCO-4 / 8-VCO-4 coupling with mounting kit: ½" flange according to ASME B16.5: 1.4539 (904L)

DN	ASME	L	P	Q	R	S	LK
½ ₂₄ to ¼"	Cl 150	11	3.50	0.62	4 × Ø 0.62	0.70	2.38
½ ₂₄ to ¼"	Cl 300	11	3.75	0.62	4 × Ø 0.62	0.82	2.62

Loose flanges (not wetted) made from stainless steel 1.4404 (316/316L)

All dimensions in [in]

4-VCO-4 / 8-VCO-4 coupling with mounting kit: JIS B2220, DN 15 flange: 1.4539 (904L)

DN	JIS	L	P	Q	R	S	LK
½ ₂₄ to ¼"	10K	11	3.74	0.59	4 × Ø 0.59	1.10	2.76

All dimensions in [in]

Purge connections / secondary containment monitoring

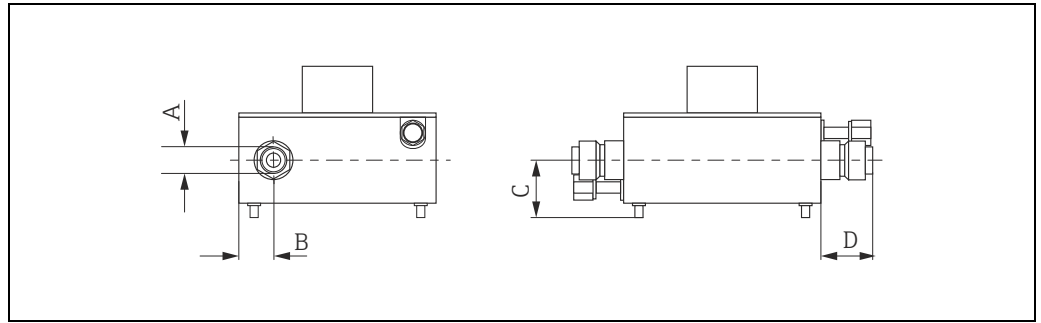

A0012335

Dimensions in SI units

DN	A	B	C	D
1 to 6	½" NPT	30	37	33

All dimensions in [mm]

Dimensions in US units

DN	A	B	C	D
½ ₂₄ to ¼"	½" NPT	1.18	1.46	1.30

All dimensions in [in]

Weight

Compact version		Remote version	
[kg]	[lb]	[kg]	[lb]
5.5	12.1	3.3	7.3

Material

Transmitter housing

- Compact version
 - Aluminium housing: powder-coated die-cast aluminium
- Remote version
 - Wall-mount housing: powder coated die-cast aluminium
 - Field housing: powder-coated die-cast aluminium

Sensor connection housing (remote version)

- Powder-coated die-cast aluminium

Sensor housing / secondary containment

- Acid-resistant and alkali-resistant external surface
- Stainless steel 1.4301(304)

Process connections

Process connection	Material
4-VCO-4 coupling 4-VCO-8 coupling	Stainless steel, 1.4539 (904L);
Mounting kit: flange according to EN1092-1 (DIN 2501) Mounting kit: flange according to ASME B16.5 Mounting kit: JIS B2220, flange	Stainless steel, 1.4539 (904L); Loose flange (not wetted): stainless steel, 1.4404 (F316/316L)
Mounting kit: NPTF threaded adapter 1/4" Mounting kit: NPTF threaded adapter 1/2"	Stainless steel, 1.4539 (904L);

Measuring tube

- 1.4539 (904L)

Seals for mounting set

- Viton
- EPDM
- Silicone
- Kalrez

Process connections

- Welded process connections
 - 4-VCO-4 -coupling (DN 1...4, DN 1/24...1/8)
 - 8-VCO-4 coupling (DN 6, DN 1/4")
- Threaded process connections
 - Flange according to EN1092-1 (DIN 2501)
 - Flange according to ASME B16.5
 - JIS B2220, flange
 - NPTF threaded adapter, 1/4", (DN 1...4, DN 1/24...1/8)
 - NPTF threaded adapter, 1/2", (DN 6, DN 1/4")

Operability

Local display**Display elements**

- Liquid crystal display: illuminated, four lines with 16 characters per line
- Selectable display of different measured values and status variables
- 3 totalizers
- At ambient temperatures below -20 °C (-4 °F), the readability of the display may be impaired.

Operating elements

- Onsite operation with three optical sensor keys (□/⊕/⊖)
- Application specific Quick Setup menus for straightforward commissioning

Language groups

Language groups available for operation in different countries:

- Western Europe and America (WEA): English, German, Spanish, Italian, French, Dutch and Portuguese
- Eastern Europe/Scandinavia (EES): English, Russian, Polish, Norwegian, Finnish, Swedish, Czech
- South and East Asia (SEA): English, Japanese, Indonesian
- China (CN): English, Chinese



Note!

You can change the language group via the operating program FieldCare.

Remote operation

Operation via HART or Modbus protocol.

Certificates and approvals

CE mark

C-Tick symbol The measuring system meets the EMC requirements of the Australian Communications and Media Authority (ACMA).

Ex approval

HART certification The flowmeter has successfully passed all the test procedures carried out and is certified and registered by the HCF (Hart Communication Foundation). The device thus meets all the requirements of the following specifications:

- Certified in accordance with HART Revisions 5 (device certification number: available on request)
- The measuring device can also be operated with certified devices of other manufacturers (interoperability).

Modbus certification The measuring device meets all the requirements of the Modbus/TCP conformity test and has the "Modbus/TCP Conformance Test Policy, Version 2.0". The measuring device has successfully passed all the test procedures carried out and is certified by the "Modbus/TCP Conformance Test Laboratory" of the University of Michigan.

Functional safety SIL 2: in accordance with IEC 61508/IEC 61511-1 (FDIS)

Pressure measuring device approval The measuring devices can be ordered with or without PED (Pressure Equipment Directive). If a device with PED is required, this must be ordered explicitly. For devices with nominal diameters less than or equal to DN 25 (1"), this is neither possible nor necessary.

- Devices with this identification (with PED) are suitable for the following types of fluid:
 - Fluids of Group 1 and 2 with a steam pressure greater than, or smaller and equal to 0.5 bar (7.3 psi)
 - Unstable gases
- Devices without this identification (without PED) are designed and manufactured according to good engineering practice. They correspond to the requirements of Art. 3, Section 3 of the Pressure Equipment Directive 97/23/EC. Their application is illustrated in Diagrams 6 to 9 in Appendix II of the Pressure Equipment Directive 97/23/EC.

Other standards and guidelines

- EN 60529: Degrees of protection provided by enclosures (IP code)
 - EN 61010-1: Safety requirements for electrical equipment for measurement, control and laboratory use
 - IEC/EN 61326: Electromagnetic compatibility (EMC requirements)
 - NAMUR Recommendation NE 21: Electromagnetic compatibility (EMC) of industrial process and laboratory control equipment
 - NAMUR Recommendation NE 43: Standardization of the signal level for the breakdown information of digital transmitters with analog output signal
 - NAMUR Recommendation NE 53: Software of field devices and signal-processing devices with digital electronics
-

Ordering Information

Detailed ordering information is available from the following sources:

→ Instruments → Select device → Product page function: Configure this product

■



Note!

Product Configurator - the tool for individual product configuration

- Up-to-the-minute configuration data
- Depending on the device: Direct input of measuring point-specific information such as measuring range or operating language
- Automatic verification of exclusion criteria
- Automatic creation of the order code and its breakdown in PDF or Excel output format
-

По вопросам продаж и поддержки обращайтесь:

Алматы (7273)495-231
Ангарск (3955)60-70-56
Архангельск (8182)63-90-72
Астрахань (8512)99-46-04
Барнаул (3852)73-04-60
Белгород (4722)40-23-64
Благовещенск (4162)22-76-07
Брянск (4832)59-03-52
Владивосток (423)249-28-31
Владикавказ (8672)28-90-48
Владимир (4922)49-43-18
Волгоград (844)278-03-48
Вологда (8172)26-41-59
Воронеж (473)204-51-73
Екатеринбург (343)384-55-89

Иваново (4932)77-34-06
Ижевск (3412)26-03-58
Иркутск (395)279-98-46
Казань (843)206-01-48
Калининград (4012)72-03-81
Калуга (4842)92-23-67
Кемерово (3842)65-04-62
Киров (8332)68-02-04
Коломна (4966)23-41-49
Кострома (4942)77-07-48
Краснодар (861)203-40-90
Красноярск (391)204-63-61
Курск (4712)77-13-04
Курган (3522)50-90-47
Липецк (4742)52-20-81

Магнитогорск (3519)55-03-13
Москва (495)268-04-70
Мурманск (8152)59-64-93
Набережные Челны (8552)20-53-41
Нижний Новгород (831)429-08-12
Новокузнецк (3843)20-46-81
Ноябрьск (3496)41-32-12
Новосибирск (383)227-86-73
Омск (3812)21-46-40
Орел (4862)44-53-42
Оренбург (3532)37-68-04
Пенза (8412)22-31-16
Петрозаводск (8142)55-98-37
Псков (8112)59-10-37
Пермь (342)205-81-47

Ростов-на-Дону (863)308-18-15
Рязань (4912)46-61-64
Самара (846)206-03-16
Санкт-Петербург (812)309-46-40
Саратов (845)249-38-78
Севастополь (8692)22-31-93
Саранск (8342)22-96-24
Симферополь (3652)67-13-56
Смоленск (4812)29-41-54
Сочи (862)225-72-31
Ставрополь (8652)20-65-13
Сургут (3462)77-98-35
Сыктывкар (8212)25-95-17
Тамбов (4752)50-40-97
Тверь (4822)63-31-35

Тольятти (8482)63-91-07
Томск (3822)98-41-53
Тула (4872)33-79-87
Тюмень (3452)66-21-18
Ульяновск (8422)24-23-59
Улан-Удэ (3012)59-97-51
Уфа (347)229-48-12
Хабаровск (4212)92-98-04
Чебоксары (8352)28-53-07
Челябинск (351)202-03-61
Череповец (8202)49-02-64
Чита (3022)38-34-83
Якутск (4112)23-90-97
Ярославль (4852)69-52-93

Россия +7(495)268-04-70

Казахстан +7(7172)727-132

Киргизия +996(312)96-26-47

эл.почта: ehr@nt-rt.ru || сайт: <https://endcounters.nt-rt.ru/>