

Датчики уровня Liquiphant FailSafe FTL80, FTL81, FTL85

Технические характеристики

По вопросам продаж и поддержки обращайтесь:

Алматы (7273)495-231
Ангарск (3955)60-70-56
Архангельск (8182)63-90-72
Астрахань (8512)99-46-04
Барнаул (3852)73-04-60
Белгород (4722)40-23-64
Благовещенск (4162)22-76-07
Брянск (4832)59-03-52
Владивосток (423)249-28-31
Владикавказ (8672)28-90-48
Владимир (4922)49-43-18
Волгоград (844)278-03-48
Вологда (8172)26-41-59
Воронеж (473)204-51-73
Екатеринбург (343)384-55-89

Иваново (4932)77-34-06
Ижевск (3412)26-03-58
Иркутск (395)279-98-46
Казань (843)206-01-48
Калининград (4012)72-03-81
Калуга (4842)92-23-67
Кемерово (3842)65-04-62
Киров (8332)68-02-04
Коломна (4966)23-41-49
Кострома (4942)77-07-48
Краснодар (861)203-40-90
Красноярск (391)204-63-61
Курск (4712)77-13-04
Курган (3522)50-90-47
Липецк (4742)52-20-81

Магнитогорск (3519)55-03-13
Москва (495)268-04-70
Мурманск (8152)59-64-93
Набережные Челны (8552)20-53-41
Нижний Новгород (831)429-08-12
Новокузнецк (3843)20-46-81
Ноябрьск (3496)41-32-12
Новосибирск (383)227-86-73
Омск (3812)21-46-40
Орел (4862)44-53-42
Оренбург (3532)37-68-04
Пенза (8412)22-31-16
Петрозаводск (8142)55-98-37
Псков (8112)59-10-37
Пермь (342)205-81-47

Ростов-на-Дону (863)308-18-15
Рязань (4912)46-61-64
Самара (846)206-03-16
Санкт-Петербург (812)309-46-40
Саратов (845)249-38-78
Севастополь (8692)22-31-93
Саранск (8342)22-96-24
Симферополь (3652)67-13-56
Смоленск (4812)29-41-54
Сочи (862)225-72-31
Ставрополь (8652)20-65-13
Сургут (3462)77-98-35
Сыктывкар (8212)25-95-17
Тамбов (4752)50-40-97
Тверь (4822)63-31-35

Тольятти (8482)63-91-07
Томск (3822)98-41-53
Тула (4872)33-79-87
Тюмень (3452)66-21-18
Ульяновск (8422)24-23-59
Улан-Удэ (3012)59-97-51
Уфа (347)229-48-12
Хабаровск (4212)92-98-04
Чебоксары (8352)28-53-07
Челябинск (351)202-03-61
Череповец (8202)49-02-64
Чита (3022)38-34-83
Якутск (4112)23-90-97
Ярославль (4852)69-52-93

Россия +7(495)268-04-70

Казахстан +7(7172)727-132

Киргизия +996(312)96-26-47

эл.почта: ehr@nt-rt.ru || сайт: <https://endcounters.nt-rt.ru/>



Level



Pressure



Flow



Temperature



Liquid
Analysis



Registration



Systems
Components



Services



Solutions

Technical Information

Liquiphant FailSafe FTL80, FTL81, FTL85

Vibronic

Point level switch for liquids



Application

The Liquiphant FailSafe is a point level switch for minimum and maximum detection (MIN/MAX) which can be used in liquids:

- Process temperatures -60 to 280 °C (-76 to 536 °F)
- Ambient temperatures -60 to 70 °C (-76 to 158 °F)
- For highly corrosive media
- Pressures up to 100 bar (1450 psi)
- Viscosity up to 10000 mPa·s
- Density from 0.4 g/cm³ (0.4 SGU)

Liquiphant FailSafe is the reliable point level switch for MIN and MAX safety applications up to SIL3.

Outstanding features of the point level switch are its fail-safe design and its high availability.

A permanent LIVE signal also monitors function safety.

Your benefits

- 4-20 mA interface (acc. to NAMUR NE 06/NE 43): easy integration via the switching unit (Nivotester FailSafe FTL825) with a two-channel output (safety contacts) and locking function or direct integration into a safety PLC
- Use in safety systems requiring functional safety to SIL3 in accordance with IEC 61508 Ed.2.0/ IEC 61511-1/ISA 84-1 and DIN EN ISO 13849
- Proof test: proof testing interval up to 12 years
- Slave devices tested at the press of a button
- Permanent self-monitoring/internal redundancy
- No adjustment: quick, low-cost startup
- No mechanically moving parts: no maintenance, no wear, long operating life
- Monitoring of fork for damage, corrosion, buildup and mechanical blocking
- 2. process seal (2nd line of defense) is provided as standard in the high-temperature version or can be optionally selected for all other versions

Table of contents

Function and system design	3	Liquid gas application	15
Point level detection	3	State of aggregation	15
Measuring principle	3	Density	15
Design	3	Viscosity depending on the operating mode	15
Measuring system	4	Solids content	15
		Lateral loading	15
Input	4	Mechanical construction	16
Measured variable	4	Housing	16
Measuring range (detection range)	4	Electronic insert	17
Density	4	Temperature spacers and pressure-tight feedthrough	17
		Process connections	17
Output: electronic insert FEL85 (4-20 mA)	5	Sensor types	18
Power supply	5	Installation height FTL80, FTL81	18
Electrical connection	5	Installation height FTL80, FTL81	19
Output signal	6	Installation height FTL85	19
Status signals	6	Weights	20
Connectable load	6	Material	21
Galvanic isolation	6		
		Operability	23
System components	6	Electronic insert	23
Nivotester FailSafe FTL825	6	Operating concept	23
		Certificates and approvals	24
Connection and function	8	CE mark, Declaration of Conformity	24
Connecting cables	8	Approvals	24
Safety mode	8	Other certificates	24
Switching time	8	CRN approval	25
Switch-on behavior	8	Process seal according to ANSI/ISA 12.27.01	25
		Ordering information	26
Performance characteristics	9	Accessories	26
Reference operating conditions	9	Sliding sleeves for unpressurized operation	26
Maximum measured error	9	High pressure sliding sleeves	27
Non-repeatability	9	Weather protection cover	28
Hysteresis	9		
Influence of process temperature on the switch point	9	Documentation	29
Influence of medium density on the switch point	9	Operating Instructions (BA)	29
Influence of process pressure on the switch point	9	Technical Information	29
		Functional safety (SIL)	29
Installation	10	Safety Instructions (ATEX, NEPSI)	29
Mounting location	10	System information	30
Examples of mounting	10		
Orientation depending on length	12		
		Environment	12
Environment	12	Ambient temperature range	12
Ambient temperature range	12	Ambient temperature limits	13
Ambient temperature limits	13	Storage temperature	13
Storage temperature	13	Climate class	13
Climate class	13	Degree of protection	13
Degree of protection	13	Vibration resistance	14
Vibration resistance	14	Electromagnetic compatibility	14
Electromagnetic compatibility	14		
		Process	14
Process	14	Process pressure PN	14
Process pressure PN	14	Test pressure	15
Test pressure	15	Process temperature	15
Process temperature	15	Thermal shock	15
Thermal shock	15		

Function and system design

Point level detection

Maximum or minimum detection for liquids in tanks or pipes (leak monitoring, dry running protection/pump protection or overflow protection), particularly for the chemical, energy and oil & gas industry. Special versions are suitable for use in hazardous areas and for applications with high pressures. As a coated version, the Liquiphant FailSafe is highly resistant to corrosion, making it particularly suitable for very aggressive liquids.

The point level switches make a distinction between two states: "covered" and "exposed". Depending on whether you have selected the MIN (minimum detection) or MAX (maximum detection) operating mode, this results in two specific scenarios in each case: the "Good" state and demand mode.

"Good" state:

The fork is covered in the MIN operating mode (e.g. pump protection).

The fork is exposed (uncovered) in the MAX operating mode (e.g. overflow protection).

Demand mode:

The fork is exposed (uncovered) in the MIN operating mode (e.g. pump protection).

The fork is covered in the MAX operating mode (e.g. overflow protection).

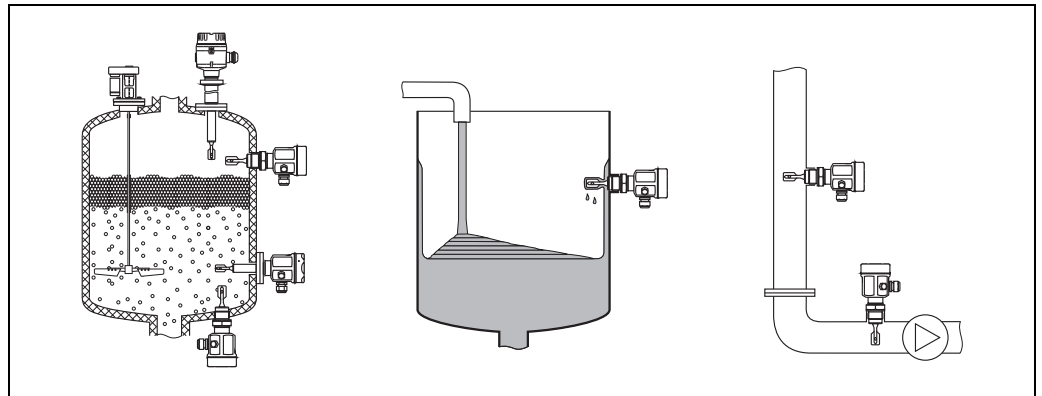

Measuring principle

The sensor's fork vibrates at its intrinsic frequency. When the tuning fork is immersed in a liquid, its intrinsic frequency changes due to the change in density of the surrounding medium. This change in frequency causes the current signal to switch.

Design

- FTL80: Compact
- FTL81: With pipe extension
- FTL85: With coated pipe extension (only flanged version)

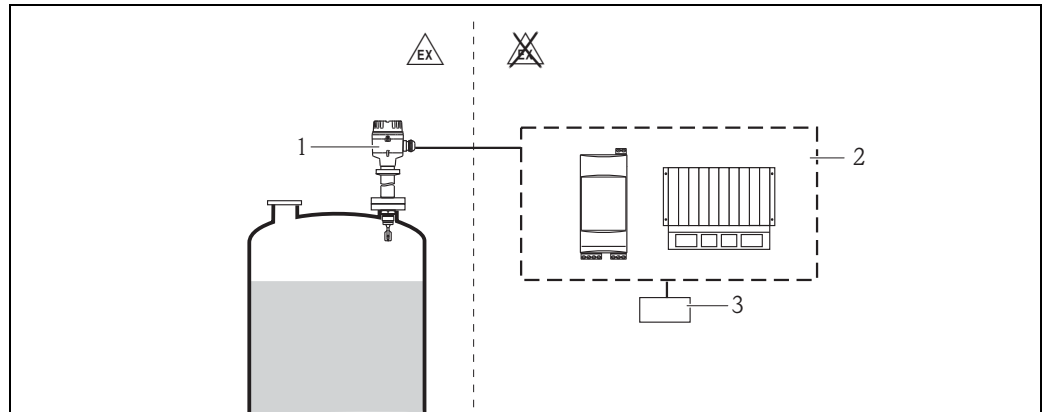
Measuring system

- 1 *Liquiphant FailSafe FTL8x with electronic insert FEL85 (4-20 mA)*
- 2 *Separate switching unit:*
 - *Nivotester FailSafe FTL825*
 - *PLC*
 - *Safety PLC*
 - ...
- 3 *Actuator*

A0017999

Input**Measured variable**

Point level (level)

Measuring range (detection range)

The measuring range depends on the mounting point and the pipe extension, where applicable.

Density

Setting on the electronic insert:

- MIN: ≥ 0.4 to $\leq 2,0$ g/cm³ (≥ 0.4 to $\leq 2,0$ SGU)
- MAX: ≥ 0.4 g/cm³ (≥ 0.4 SGU)

Output: electronic insert FEL85 (4-20 mA)

Power supply

Nominal supply voltage: DC 24 V
 Supply voltage range: DC 12 to 30 V
 Power consumption: < 660 mW
 Reverse polarity protection: yes

Electrical connection

Two-wire connection

For connecting to the Nivotester FailSafe FTL825, a programmable logic controller (PLC), a safety PLC (SPLC) or AI modules 4-20 mA as per EN 61131-2.
 Output signal jump from high to low current when the point level is reached.

Minimum detection (MIN)

Maximum detection (MAX)

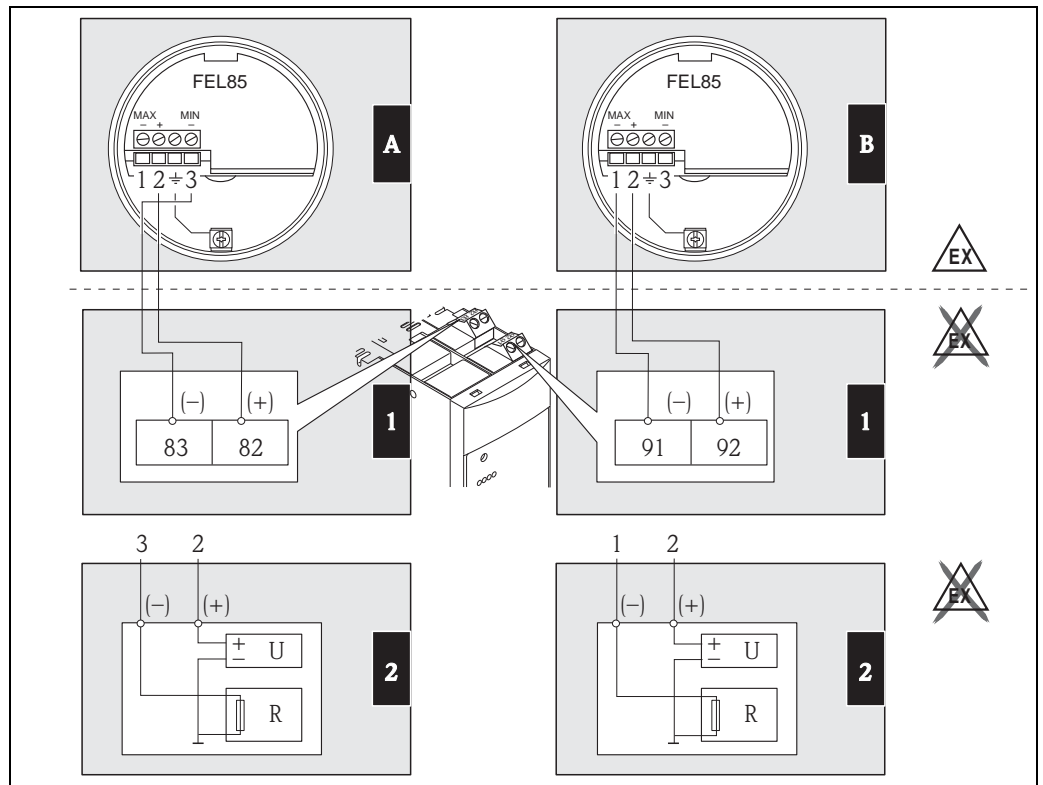

A0018062







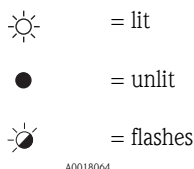

A+1: FEL85 with Nivotester FailSafe FTL825
 A+2: FEL85 with a PLC or safety PLC

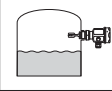
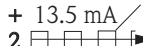
B+1: FEL85 with Nivotester FailSafe FTL825
 B+2: FEL85 with a PLC or safety PLC

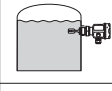
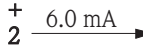
Output signal

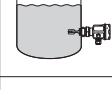
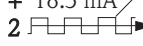

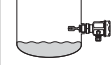
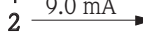
A0018064

Safety mode	Level	Output signal	LEDs	
			green	yellow
MAX		+ 13.5 mA 2  1		
		+ 6.0 mA 2  1		
MIN		+ 18.5 mA 2  3		
		+ 9.0 mA 2  3		

A0018065

* A permanent LIVE signal (0.25 Hz frequency, ± 0.5 mA amplitude) is superimposed on the sensor output signal in the "Good" state (\neq demand mode)

Status signals

The status signals (LEDs) make a distinction between the following states:

- Operation: normal state
- Function check: end proof test*
- Outside specification: correct density setting*
- Maintenance required: clean sensor*
- Failure: replace electronic insert*
- Failure: check power supply
- Failure: replace device*

* Output current: < 3.6 mA (error current as per NAMUR NE 43)

Connectable load

$R = (U - 12 \text{ V}) / 22 \text{ mA}$
 U = supply voltage range: DC 12 to 30 V

Galvanic isolation

Between sensor and power supply

System components

Nivotester FailSafe FTL825

The Nivotester supplies direct current to the Liquiphant FailSafe FTL8x sensor via a two-wire cable. From here it receives a 4 to 20 mA current whose value is used to interpret the switching state. The intrinsically safe signal inputs of the Nivotester FTL825 point level switch are galvanically isolated from the mains and the output.

Mains voltage version

- Nominal supply voltage: AC/DC 230/115 V
- Supply voltage range: AC 85 to 253 V, 50/60 Hz
DC 85 to 253 V
- Power consumption: $\leq 3.8 \text{ VA}$, $\leq 2.0 \text{ W}$

Extra-low voltage version

- Nominal supply voltage: AC/DC 24 V
- Supply voltage range:
AC 20 to 30 V, 50/60 Hz
DC 20 to 60 V
- D/C power supply: maximum 95 mA
- Permitted residual ripple inside the tolerance: $U_{ss} = \text{maximum } 2 \text{ V}$

Power consumption: $\leq 3.6 \text{ VA}$, $\leq 2.5 \text{ W}$

Reverse polarity protection: yes

Overvoltage protection FTL825: category II (2000 m (6562 ft) above MSL)

Electrical connection

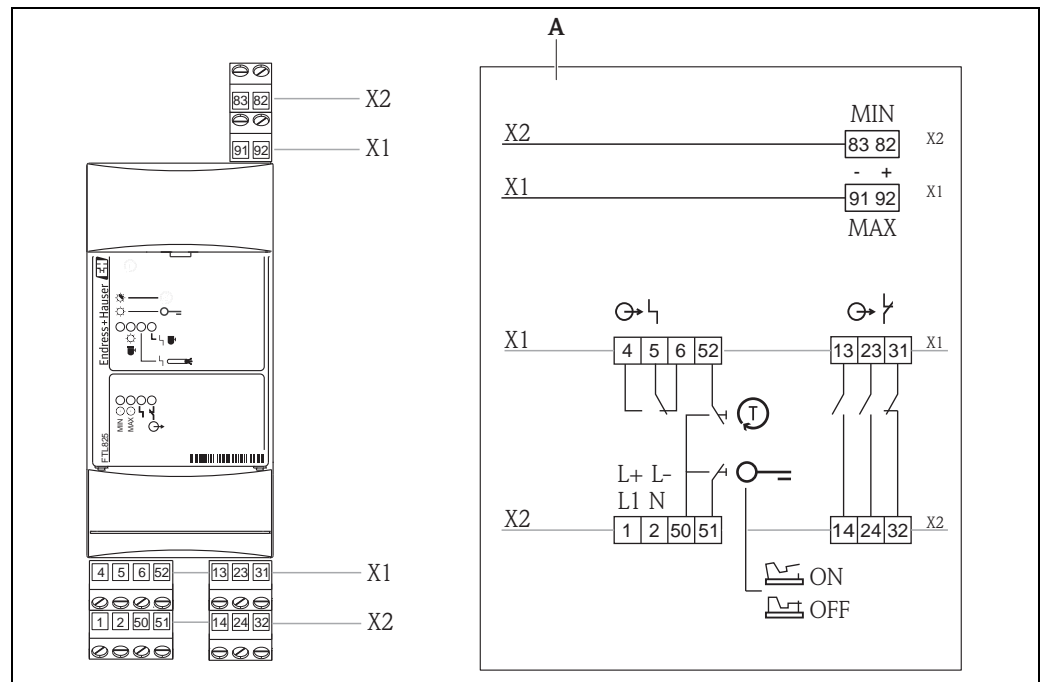

A Front flap (open)

Terminal blocks

The removable terminal blocks are divided into intrinsically safe terminals (at the top of the device) and non-intrinsically safe terminals (at the bottom of the device). This distinction enables the safe routing of the connecting cable.

Connecting the sensor (top terminal blocks)

Only a Liquiphant FailSafe FTL8x sensor may be connected to the Nivotester FailSafe FTL825. MIN/MAX operating mode can be selected via connection wiring. A commercially available instrument cable can be used for the twin-core connecting cable between the two devices. Maximum 25 Ω cable resistance per core. Maximum 100 nF cable capacitance.

A shielded cable should be used if strong electromagnetic interference is expected (from machines or radio equipment). The shield is connected to the ground connection in the sensor. The use of shielded cables can improve EMC interference immunity.

Using the sensor in hazardous areas

Observe national explosion protection regulations surrounding the design and routing of intrinsically safe circuits.

Please refer to the associated safety instructions for information on the capacitance and inductance limit values. For more information on the documents, → [29](#).

Connecting the signal and control units (bottom terminal blocks)

Pay attention to the relay function depending on the level and fail-safe mode.

If a high-inductance device is connected (e.g. contactor, solenoid valve etc.), a spark arrester must be provided to protect the relay contact.

Connecting the supply voltage (bottom terminal blocks)

As a fuse is incorporated in the power supply circuit it is not necessary to connect an upstream fine-wire fuse. The Nivotester has reverse polarity protection.

Output signal

- Relay outputs:
 - Two floating NO contacts (supervised safety contacts based on the quiescent current principle) with an integrated 3.15 A fuse (exchangeable)
 - Quiescent current operating mode: MIN/MAX (operating mode can be selected via connection wiring)
 - One floating NC contact (signaling contact)
 - Fault-signaling relay: floating changeover contact for error signaling
- Switching capacity per relay contact:
 - U ~ maximum 253 V
 - I ~ maximum 2 A
 - P ~ maximum 500 VA at $\cos \varphi \geq 0.7$

 - U = maximum 40 V
 - I = maximum 2 A
 - P = maximum 80 W
- Operating life: at least 10^5 switching operations with maximum contact load
- Recommended minimum current: 1 mA
- Function indicators: light emitting diodes for operation, point level and error

Signal on alarm

Safety contacts open, signaling contact closed, error signaled by red LED

Installation

Vertically on DIN top-hat rail (mounting rail (TS 35) as per EN 50022)

Dimensions

B/H/D: 45 mm (1.77 in), 108 mm (4.25 in), 112 mm (4.41 in)

Technical Information

More information on the FTL825 is available on our product pages under Nivotester FailSafe FTL825, document number: TI01027F

Connection and function

Connecting cables

- Electronic insert: cross-section max. 2.5 mm² (14 AWG)
- Maximum cable length: 1000 m (3281 ft)
- Maximum 25 Ω cable resistance per core
- Maximum 100 nF cable capacitance
- Protective ground in housing: cross-section max. 2.5 mm² (14 AWG)
- External equipotential bonding connection on housing: cross-section max. 4 mm² (12 AWG)

Safety mode

Minimum/maximum detection (MIN/MAX) can be selected by connection coding on the electronic insert (→  5, Electrical connection).

MAX = maximum detection:

The output switches in a safety-oriented manner when the probe is covered (demand mode).

For use with overflow protection for example

MIN = minimum detection:

The output switches in a safety-oriented manner when the probe is uncovered (demand mode).

For use with dry running protection, pump protection for example

Switching time

- When fork is covered: approx. 0.5 s ± 0.2 s
- When fork is exposed: approx. 1.0 s ± 0.2 s
- Dwell time: at least 0.3 s

Switch-on behavior

When switching on the power supply, the output assumes the alarm signal.

Operational after max. 4 s

Performance characteristics

Reference operating conditions

Operating mode: MAX
 Ambient temperature: $23 \pm 5 \text{ }^\circ\text{C}$ ($73 \pm 41 \text{ }^\circ\text{F}$)
 Process temperature: $23 \text{ }^\circ\text{C}$ ($73 \text{ }^\circ\text{F}$)
 Medium density: 1 g/cm^3 (water), 1 SGU (water)
 Viscosity: 1 mPa·s
 Process pressure: 1 bar abs. (15 psi)
 Sensor mounting: vertical from above
 Low density switch to 0.7 g/cm^3 (0.7 SGU)
 High density switch to $>2.0 \text{ g/cm}^3$ (2.0 SGU)

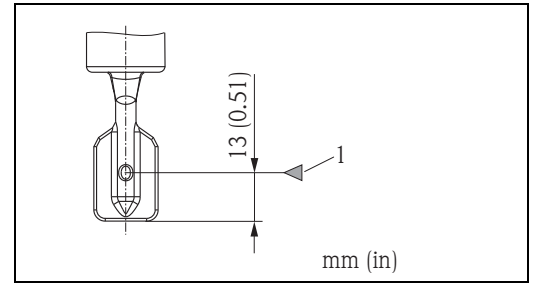

1 Switch point at reference operating conditions



Note!

Outside the reference operating conditions, the switch point is in the range of the fork tine. (See also installation conditions → 10.)

Maximum measured error $\pm 1 \text{ mm}$ ($\pm 0.04 \text{ in}$)

Non-repeatability 0.1 mm (0.004 in)

Hysteresis

- FTL80, FTL81, FTL85 (ECTFE and PFA): approx. 2 mm (0.08 in)
- FTL85 (enamel): approx. 2.5 mm (0.1 in)

Influence of process temperature on the switch point

	Process temperature ($^\circ\text{C}$)	Process temperature ($^\circ\text{C}$)	Influence on the switch point (mm)	Influence on the switch point (in)
FTL80, FTL81	-50 to +150	-58 to 300	+1.8 to -2.8	+0.07 to -0.11
FTL80, FTL81	-60 to +280	-76 to 540	+1.4 to -5.5	+0.06 to -0.22
FTL85 ECTFE	-50 to +120	-58 to 250	+1.4 to -2.8	+0.06 to -0.11
FTL85 PFA	-50 to +150	-58 to 300	+1.4 to -2.8	+0.06 to -0.11
FTL85 enamel	-50 to +150	-58 to 300	+0.6 to -1.5	+0.02 to -0.06

Influence of medium density on the switch point

	Process density (g/cm^3)	Process density (SGU)	Influence on the switch point (mm)	Influence on the switch point (in)
FTL8x	0.5 to 1.5	0.5 to 1.5	+4.8 to -3.5	+0.19 to -0.14

Influence of process pressure on the switch point

	Process pressure (bar)	Process pressure (psi)	Influence on the switch point (mm)	Influence on the switch point (in)
FTL8x	-1 to 64	-14.5 to 928	0 to -2.5	0 to -0.1
FTL8x	-1 to 100	-14.5 to 1450	0 to -3.9	0 to -0.15

Installation

Mounting location

Switch points on the sensor depend on the mounting position (outside reference operating conditions).

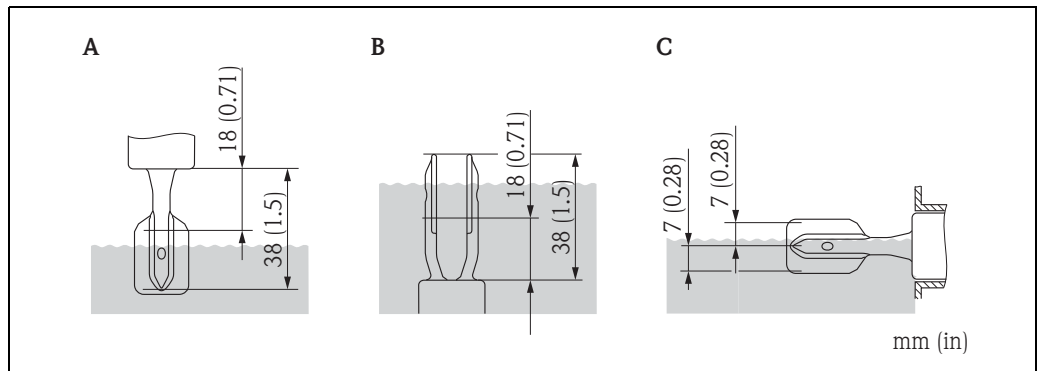

- A *Mounting from above*
- B *Mounting from below*
- C *Mounting from the side*

Examples of mounting

Examples of mounting with regard to the viscosity ν of the liquid and the tendency to form buildup

Optimum mounting, trouble-free even with high viscosity

Position the fork so that the narrow edge of the tines is vertical to ensure that the liquid can run off easily.

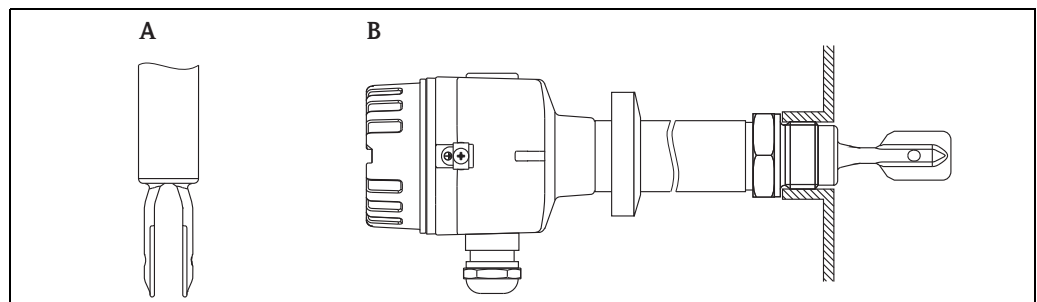

- A *Vertical from above*
- B *Flush-mounted from the side*

With buildup on the tank walls

* Ensure that there is sufficient distance between the buildup expected on the tank wall and the fork.

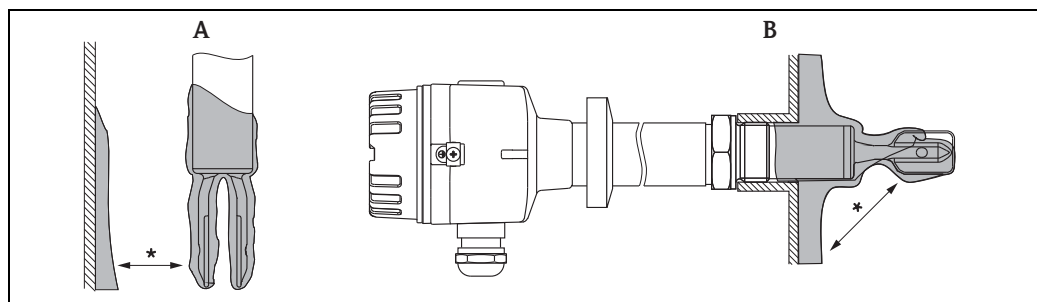

- A *Vertical from above*
- B *Protruding into the tank from the side*

Mounting positions with low viscosity up to 2000 mPa-s

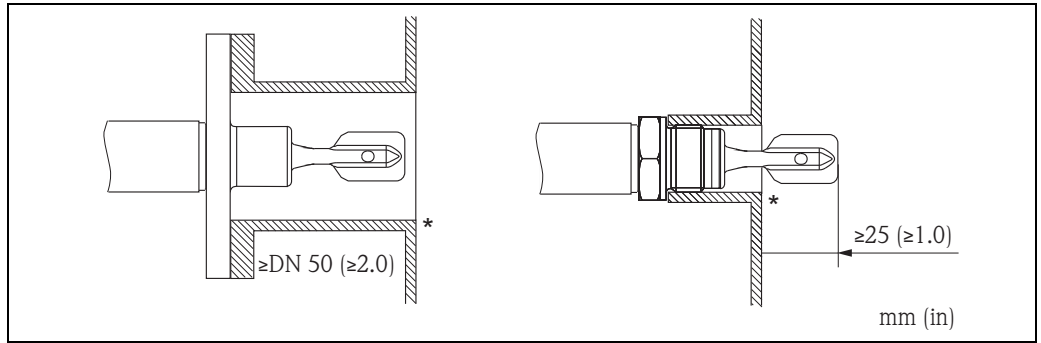

* *Deburr the socket surfaces*

Mounting in piping from 2"

Flow velocities up to 5 m/s (16.4 ft/s) for viscosity 1 mPa-s and density 1 g/cm³ (1 SGU). (Check the function for other process conditions.)

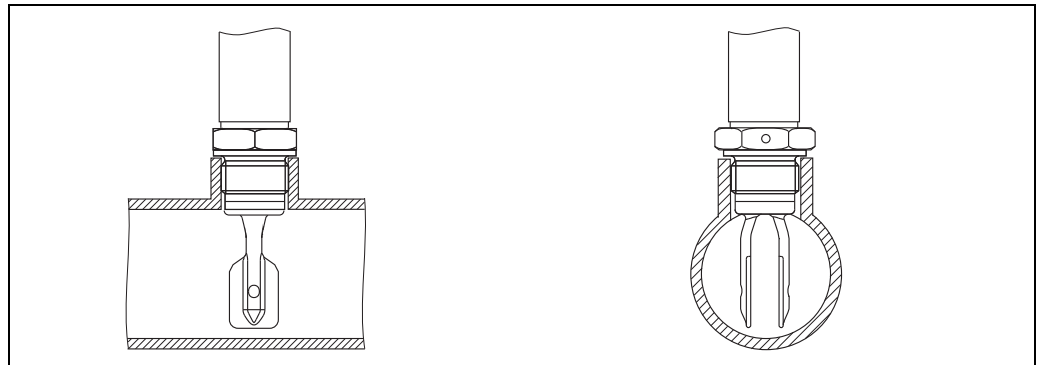

Support the Liquiphant FailSafe FTL81 and FTL85 in the event of severe dynamic load.

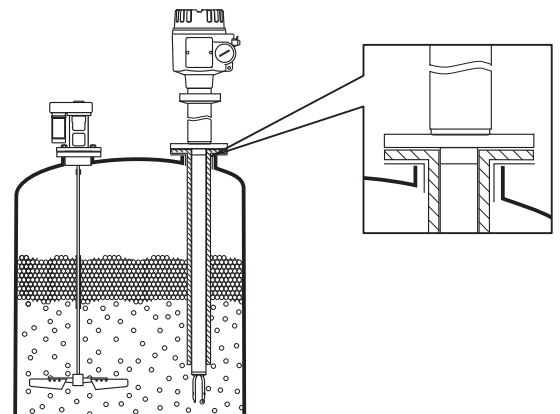

A0018186

A0018187

A0018188

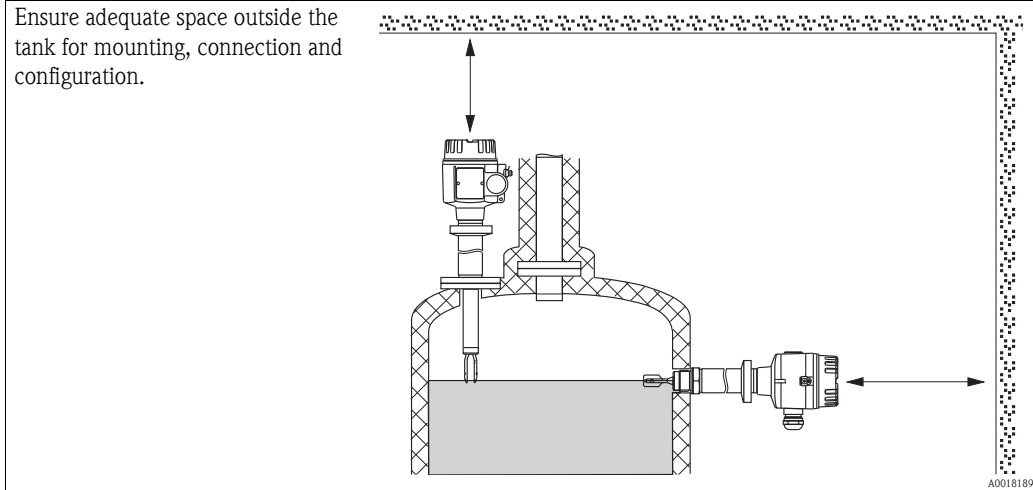

Orientation depending on length

<500 mm (<20 in): any orientation
>500 mm (>20 in): vertical

Environment

Ambient temperature range

Version with maximum process temperature of 150 °C (300 °F)

Permitted ambient temperature T_a at the housing depending on the process temperature T_p in the tank:

- T_a -40 °C (-40 °F) standard
- T_a -50 °C (-58 °F) optional

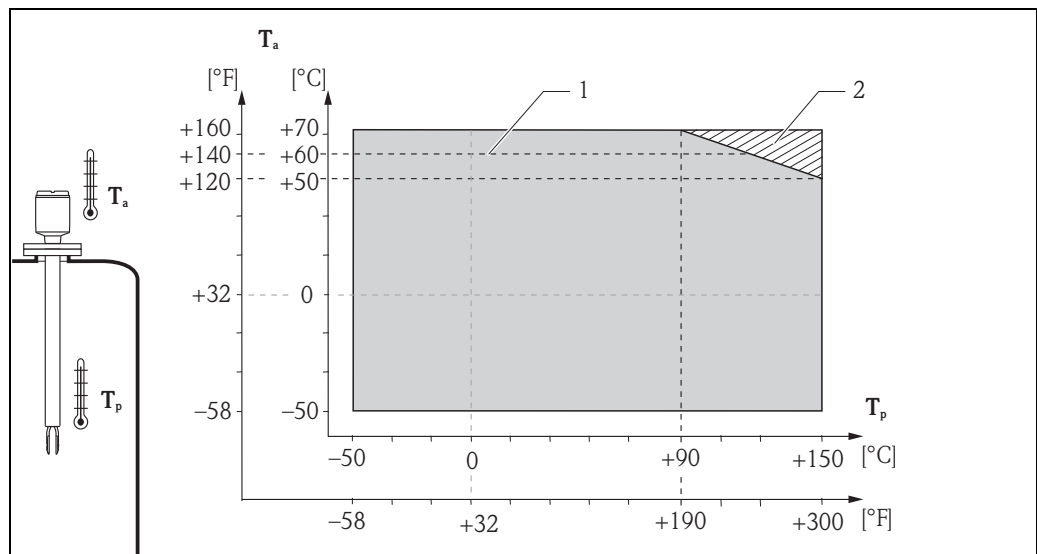

- 1 Maximum ambient temperature in hazardous areas (T_0) and with intrinsically safe power
- 2 Additional temperature range for devices with a temperature spacer or pressure-tight feedthrough



Note! FTL85

The temperature difference between the process temperature and ambient temperature ($T_p - T_a$) of the flange may not exceed 60 °C (140 °F) for switches with ECTFE or PFA coating. The flange has to be included in the tank insulation where necessary.

Version with maximum process temperature of 230/280 °C (450/540 °F)

(only FTL80 and FTL81)

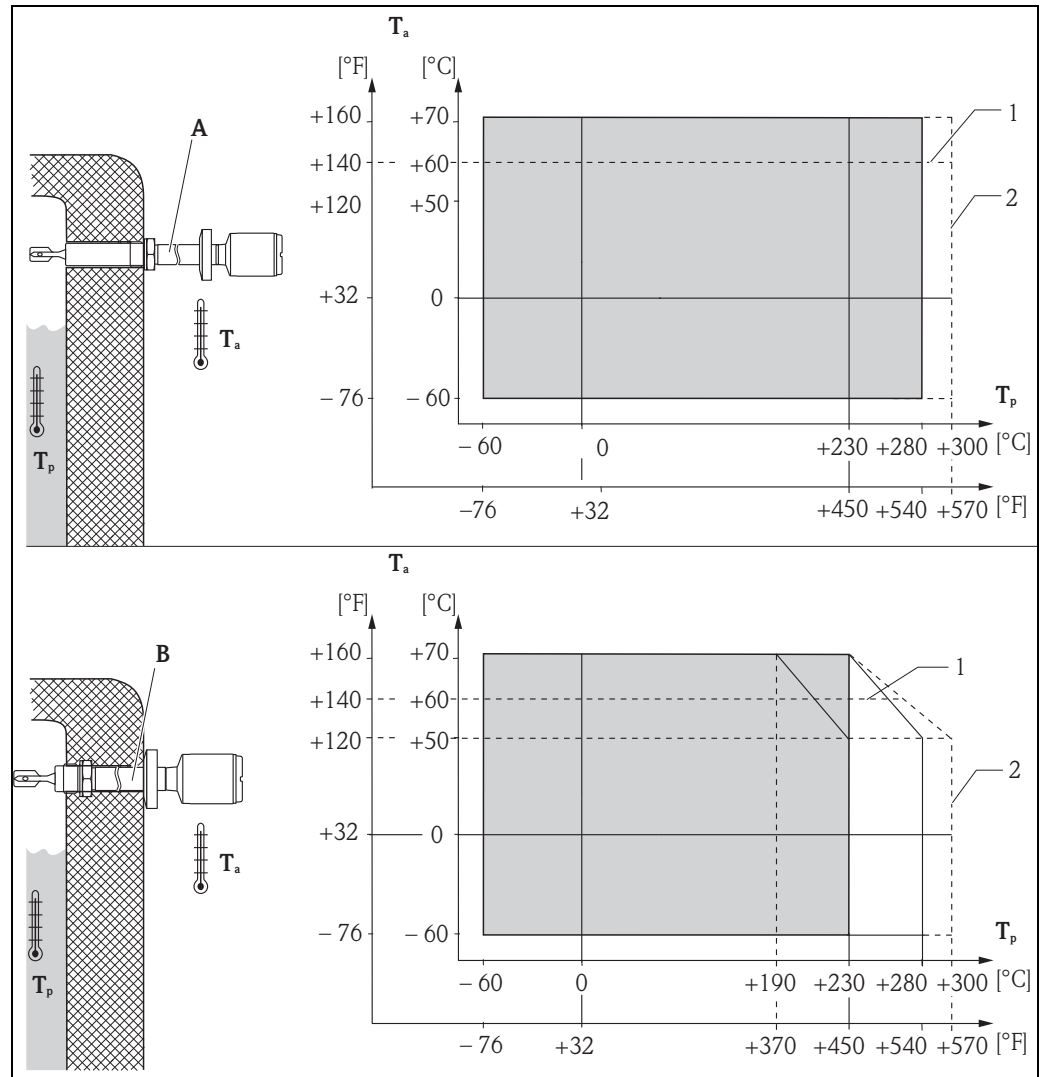

- A** Temperature spacer **outside** insulation
- B** Temperature spacer **inside** insulation
- 1 Maximum ambient temperature in hazardous areas (T_b) and with intrinsically safe power
- 2 Maximum 50 cumulative hours

Ambient temperature limits -40 to +70 °C (-40 to +160 °F)
 Optional: -50 to +70 °C (-58 to 160 °F) and -60 to +70 °C (-76 to 160 °F)

Storage temperature -50 to +80 °C (-58 to 176 °F)

Climate class Climate protection to IEC 60068, Part 2-38, Fig. 2a

Degree of protection

Types of housing	IP66*	IP67*	IP68*	NEMA**
Polyester housing F16	X	X	-	4X
Stainless steel housing F15	X	X	-	4X
Aluminum housing F17	X	X	-	4X
Aluminum housing F13	X	-	X	4X/6P
Stainless steel housing F27	X	-	X	4X/6P
Aluminum housing T13 with separate connection compartment (Ex d)	X	-	X	4X/6P

* As per EN60529; ** As per NEMA 250

Vibration resistance As per IEC 60068-2-64, load class 1 (m/s²)²/Hz, 3 x 100 minutes

Electromagnetic compatibility Electromagnetic compatibility in accordance with all of the relevant requirements in the EN 61326 series and NAMUR Recommendation NE 21 EMC. Please refer to the Declaration of Conformity for details.
1 % span ≤160 μA

Process

Process pressure PN

FTL80, FTL81:

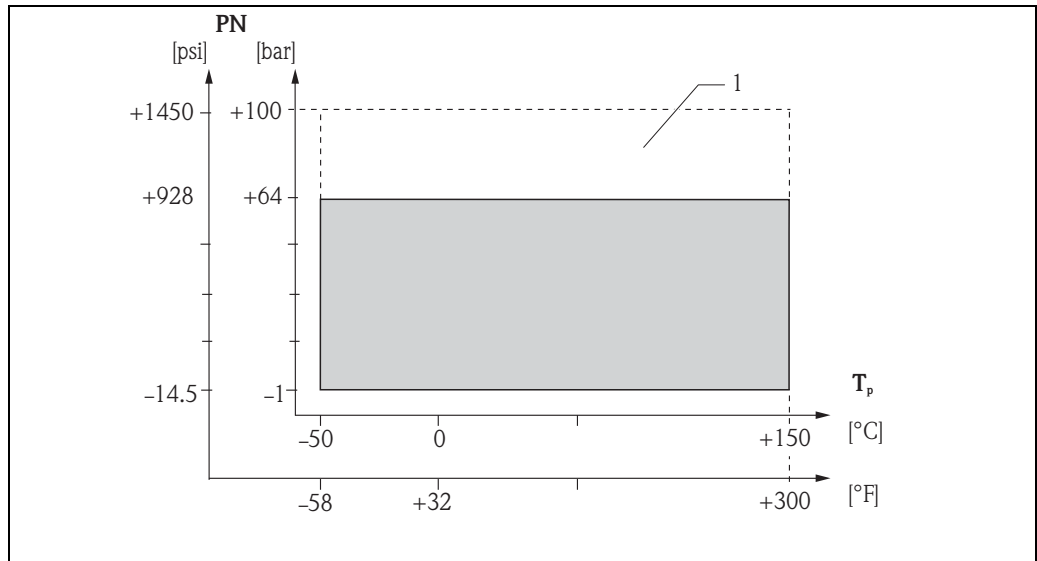

A0018192

1 Allowed pressure rating when the "100 bar (1450 psi)" option is selected (FTL81)

FTL80, FTL81 (230/280 °C (450/540 °F)):

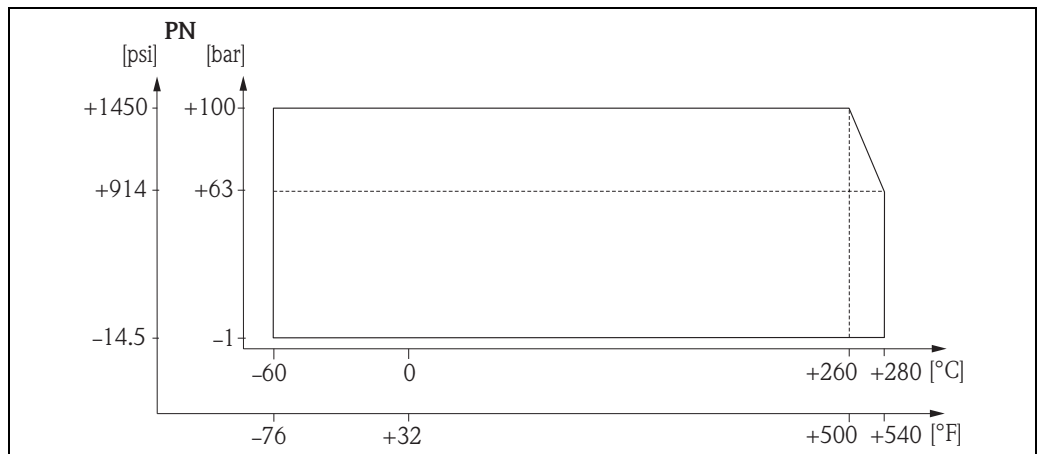

A0018193

Only with high-temperature version

FTL85		
ECTFE -1 to +40 bar (-14.5 to 580 psi)	PFA -1 to +40 bar (-14.5 to 580 psi)	Enamel -1 to +25 bar (-14.5 to 360 psi)



Note!

Please refer to the standards listed for the permitted pressure values of the flanges at higher temperatures:

- pR EN 1092-1: 2005

With regard to their stability-temperature property, the materials 1.4435 and 1.4404 are identical and are grouped together under 13E0 in EN1092-1 Tab. 18. The chemical composition of the two materials can be identical.

- ASME B 16.5a - 2009 Tab. 2.2.3 F316L
- ASME B 16.5a - 2009 Tab. 2.3.8 N06022 and N06455
- JIS B 2220

The lowest value from the derating curves of the device and selected flange applies in each case.

Test pressure

FTL80/81 ($p_N = 64$ bar (960 psi)): 100 bar (1450 psi) → 1.5 times the process pressure p_N ; no function during test pressure; burst pressure >200 bar (>2900 psi)

FTL80/81 ($p_N = 100$ bar (1450 psi)): 150 bar (2250 psi) → 1.5 times the process pressure p_N ; no function during test pressure; burst pressure >400 bar (>5800 psi)

FTL85 ($p_N = 25$ or 40 bar (363 or 580 psi)): 38 or 60 bar (550 or 870 psi) → 1.5 times the process pressure p_N ; no function during test pressure; burst pressure >400 bar (>5800 psi)

Process temperature

- FTL80, FTL81

-50 to +150 °C (-58 to +300 °F)

-60 to +280 °C (-76 to +540 °F) (high-temperature version: 300 °C (572 °F) for a maximum of 50 cumulative hours)

- FTL85

ECTFE: -50 to +120 °C (-58 to +248 °F)

PFA: -50 to +150 °C (-58 to +300 °F)

Enamel: -50 to +150 °C (-58 to +300 °F)

Thermal shock

Maximum 120 °C/s (300 °F/s) without restriction within the process temperature range)

Liquid gas application

Process temperature: -50 to +60 °C (-58 to +140 °F)

State of aggregation

Liquid

Density

The density is set at two rotary switches ("Low" density and "High" density).

MAX	Medium	"Low" density in g/cm ³ (SGU) ρ_{LOW}	"High" density in g/cm ³ (SGU) ρ_{HIGH}
Combination 1	Liquefied gas	0.4 (0.4)	2.0 (2.0)
Combination 2	Other liquids	0.7 (0.7)	> 2.0 (> 2.0)
MIN	Medium	"Low" density in g/cm ³ (SGU) ρ_{LOW}	"High" density in g/cm ³ (SGU) ρ_{HIGH}
Combination 1	Liquefied gas	0.4 (0.4)	0.7 (0.7)
Combination 2	e.g. alcohol	0.6 (0.6)	0.9 (0.9)
Combination 3	e.g. water	0.7 (0.7)	1.2 (1.2)
Combination 4	e.g. acid	0.9 (0.9)	2.0 (2.0)



Note!

Other density setting combinations are not permitted.

Viscosity depending on the operating mode

MAX: ≤ 10000 mPa·s

MIN: ≤ 350 mPa·s

MIN: coating, high temperature (230/280 °C (450/536 °F)) ≤ 100 mPa·s

Solids content

Maximum ø5 mm (0.2 in)

Lateral loading

≤ 75 Nm (55.32 lbf ft)

Mechanical construction



Note!
All dimensions in mm (in)!

Housing

* Cover with sight glass (optional).

Polyester housing F16

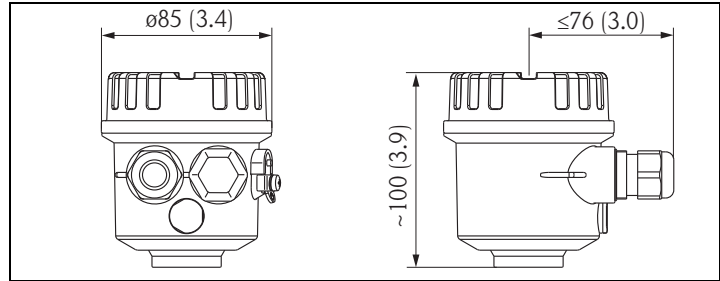

A0018195

Stainless steel housing F15

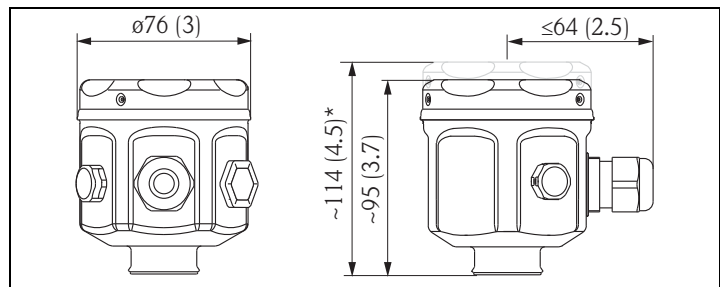

A0018196

Aluminum housing F17

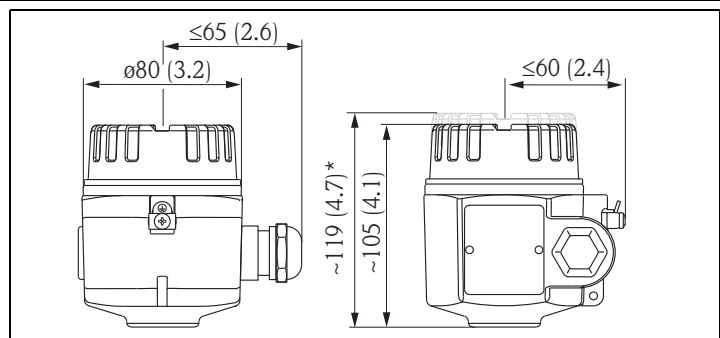

A0018197

*Aluminum housing F13***

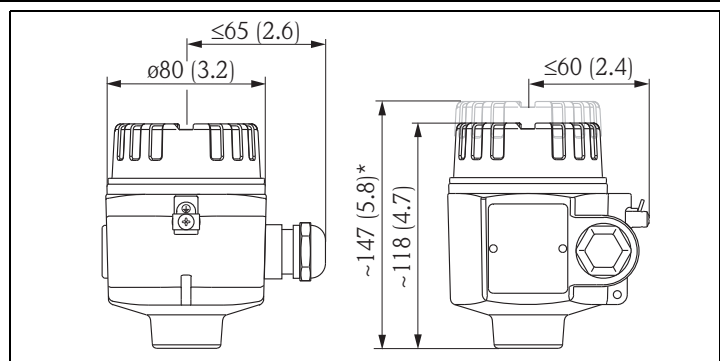

A0018199

*Stainless steel housing F27***

** Bolted connection to sensor.

*Aluminum housing T13
with separate connection
compartment*

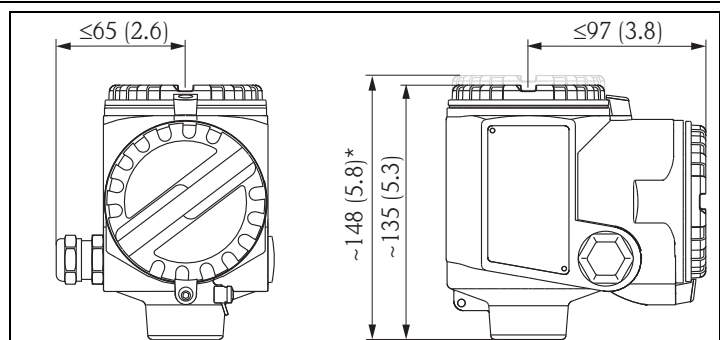

A0018200



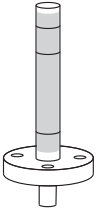
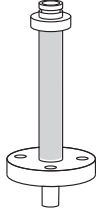

Electronic insert

FEL85	
 <small>A0018201</small>	Output 4-20 mA for separate switching unit Nivotester FailSafe FTL825 or PLC/SPLC

Temperature spacers and pressure-tight feedthrough

	Temperature spacer	Pressure-tight feedthrough (second line of defense)	Temperature spacer including welded gas-tight feedthrough	
	 <small>A0018213</small>	 <small>A0018214</small>		
Maximum temperature	≤150 °C (≤300 °F)		<230 °C (450 °F)	<280 °C (540 °F)
<p>Temperature spacer: for bypassing any existing tank insulation. The additional distance to the process reduces the ambient temperature present at the housing.</p> <p>Pressure-tight feedthrough: sealed with an O-ring. Recommended if there is a risk of damage to the sensor particularly in the case of dangerous media or where there is medium to high probability of condensation forming.</p> <p>Pressure-tight feedthrough: welded diffusion-resistant glass feedthrough. Recommended if there is a risk of damage to the sensor particularly in the case of dangerous and very dangerous media or where there is a high probability of condensation forming.</p>				

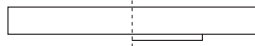
Process connections

	Thread G cylindrical		Thread R, NPT tapered		Flanges FTL80, FTL81	Flanges FTL85 (coated)
	 <small>A0018215</small>		 <small>A0018216</small>		 <small>A0018217</small>	
Thread size	¾	1*	¾	1	—	—
Width across flats (SW = AF)	32	41	32	41	—	—
Standard	DIN EN ISO228-I		DIN 2999 (R) ANSI B 1.20.1 (NPT)		ANSI B 16.5 (RF) EN 1092-1 (Form A/B)/DIN 2527 B JIS B 2220 (RF)	
For pressures (bar (psi)) to	100 (1450)		100 (1450)		100 (1450)	See nominal pressure of flange, however ECTFE and PFA (Edlon**): 40 (580) Enamel: 25 (360)
For temperatures (°C (°F)) to	280 (5410)		280 (5410)		280 (5410)	ECTFE: 120 (250) PFA (Edlon**): 150 (300) Enamel: 150 (300)
Seals	Elastomer flat seal to DIN7603		—		Depending on design: provided by the customer	Synthetic coating: PTFE seal supplied Enamel coating: seal provided by the customer
<p>* Please beware of pressure and temperature specifications if installing in weld-in adapter! →  29 "Technical Information" → Weld-in adapter</p> <p>** FDA-compliant material in accordance with 21 CFR Part 177.1550/2600</p>						

Sensor types

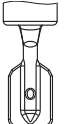
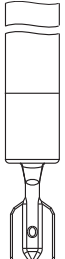
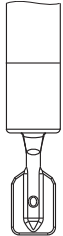
Compact FTL80	Pipe extension FTL81 FTL85	Short pipe version FTL81 FTL85	Compact or with pipe extension up to 3 m (10 ft)
			<p>Note: The Liquiphant FailSafe FTL8x has different switch points to its predecessor the Liquiphant FailSafe FDL6x.</p> <p>Special length "short pipe version" With vertical mounting the switch point is the same as for the Liquiphant FailSafe FDL60 "L" depends on process connection: L = 115 mm (4.5 in) for flanges and flange-like process connections L = 99 mm (4.0 in) for threads NPT and R (BSPT) L = 118 mm (4.7 in) for threads G1 (BSP 1) L = 115 mm (4.5 in) for threads G 3/4 (BSP 3/4) L = 104 mm (4.1 in) for flush-mounted 1</p>
A0018218			

 Installation height FTL80,
FTL81

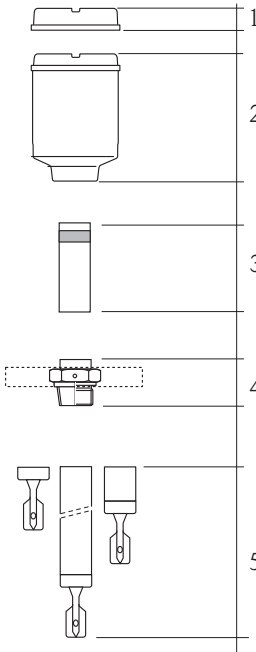
Drawing	Number	Description	Housing					
			F16	F15	F17	F27	F13	T13
	1	Cover with sight glass (optional)	0	19	14	29	13	
	2	Housing with cover	100	95	105	118	135	
	3	Temperature spacer to 150 °C (optional) Pressure-tight feedthrough Pressure-tight feedthrough sealed with an O-ring (optional)	140					
	4**	Thread G 3/4	20			15		
		Thread G 1						
		Thread R 3/4						
		Thread R 1	41			38		
		Thread NPT 3/4						
		Thread NPT 1						
	5	Flange	55			64		
			Thread					Flange
			G 3/4	G 1	G 1***	R, NPT 3/4	R, NPT 1	
	5	Short pipe version	115	118	104	99		115
		Pipe extension*	148 to 3000					
Sensor (compact)**		66.5	69	80	50.5		66.5	

* Can only be selected for FTL81.

** To seal surface for G thread and flange or lower edge of thread for NPT and R thread.

*** When flush-mounted.

Installation height FTL80, FTL81 **High-temperature version (230/280 °C (450/540 °F))**

Drawing	Number	Description	Housing						
			F16	F15	F17	F27	F13	T13	
	1	Cover with sight glass (optional)	0	19	14	29	13		
	2	Housing with cover	100	95	105	118	135		
	2	Temperature spacer to 230 °C + pressure-tight feedthrough (welded diffusion-resistant glass feedthrough)	163						
	3	Temperature spacer to 280 °C + pressure-tight feedthrough (welded diffusion-resistant glass feedthrough)	203						
	4	4**	Thread G 3/4	17					
			Thread G 1	17					
			Thread R 3/4	37					
			Thread R 1	37					
			Thread NPT 3/4	37					
			Thread NPT 1	37					
	5	5	Flange	As per flange standard					
				Thread			Flange		
				G 3/4	G 1	R, NPT 3/4	R, NPT 1		
			Pipe extension*	148 to 3000					
			Sensor (compact)**	66.5	69	50.5	66.5		

A0018220

* Can only be selected for FTL81.
 ** To seal surface for G thread and flange or lower edge of thread for NPT and R thread.

Installation height FTL85 **Coated version**

Drawing	Number	Description	Housing						
			F16	F15	F17	F27	F13	T13	
	1	Cover with sight glass (optional)	0	19	14	29	13		
	2	Housing with cover	100	95	105	118	135		
	2	Temperature spacer to 150 °C (optional)	140						
	3	Pressure-tight feedthrough sealed with an O-ring (optional)	140						
	3	4	Flange	55			64		
	5	5	Short pipe version	115					
			Pipe extension	148 to 3000					

A0018221

Weights

The total weight of a typical Liquiphant FailSafe device can be calculated by adding the individual components to the basic weight.

Basic weight	Weight in kg (lbs)
The basic weight comprises: <ul style="list-style-type: none"> ■ Sensor (compact) ■ Thread G ¾ ■ Electronic insert ■ Polyester housing F16 ■ Housing cover 	0.7 (1.5)
Housing	kg (lbs)
Aluminum housing F13 (connection: NPT¾, G½ or M20)	0.5 (1.1)
Stainless steel housing F15 (connection: NPT½, G½, M20 or M12 connector)	0.1 (0.2)
Aluminum housing F17 (connection: NPT¾, G½, M20 or M12 connector)	0.5 (1.1)
Stainless steel housing F27 (connection: NPT½, G½ or M20)	0.3 (0.7)
Aluminum housing T13 with separate connection compartment (connection: NPT¾, G½ or M20)	0.9 (2)
Temperature spacer	kg (lbs)
1 piece	0.6 (1.3)
Pressure-tight feedthrough	kg (lbs)
1 piece	0.7 (1.54)
Process connection: threaded connection	kg (lbs)
G ¾, 316L, thread ISO 228	*
G ¾, AlloyC22, thread ISO 228	*
G 1, 316L, thread ISO 228	0.2 (0.4)
G 1, AlloyC22, thread ISO 228	0.2 (0.4)
R ¾, 316L, thread DIN 2999	*
R ¾, AlloyC22, thread DIN 2999	*
R 1, 316L, thread DIN 2999	0.2 (0.4)
R 1, AlloyC22, thread DIN 2999	0.2 (0.4)
NPT ¾, 316L, thread ANSI	*
NPT ¾, AlloyC22, thread ANSI	*
NPT 1, 316L, thread ANSI	0.2 (0.4)
NPT 1, AlloyC22, thread ANSI	0.2 (0.4)
* Included in the basic weight	
Process connection: EN flanges	kg (lbs)
DN25 PN25/40 A, 316L, flange EN 1092-1 (DIN 2527 B)	1.4 (3.1)
DN25 PN25/40 B1, 316L, flange EN 1092-1 (DIN 2527 C)	1.3 (2.9)
DN25 PN25/40 B1, AlloyC22 >1.4462, flange EN 1092-1 (DIN 2527)	1.3 (2.9)
DN25 PN40 B1, 316L, flange EN 1092-1 (DIN 2526 D)	1.4 (3.1)
DN32 PN25/40 A316L, flange EN 1092-1 (DIN 2527 B)	2.0 (4.4)
DN40 PN25/40 A316L, flange EN 1092-1 (DIN 2527 B)	2.4 (5.3)
DN50 PN10/16 B1316L, flange EN 1092-1 (DIN 2527 C)	2.5 (5.5)
DN50 PN25/40 A316L, flange EN 1092-1 (DIN 2527 B)	3.2 (7.1)
DN50 PN25/40 B1316L, flange EN 1092-1 (DIN 2527 C)	2.9 (6.4)
DN50 PN40 B1, 316L, flange EN 1092-1 (DIN 2526 D)	2.9 (6.4)
DN50 PN25/40 B1, AlloyC22 >1.4462, flange EN 1092-1 (DIN 2527)	2.9 (6.4)
DN50 PN63 A, 316L, flange EN 1092-1 (DIN 2527 B)	4.5 (9.9)
DN50 PN63 B2, 316L, flange EN 1092-1 (DIN 2527 E)	4.5 (9.9)
DN50 PN63 B1, AlloyC22 >1.4462, flange EN 1092-1 (DIN 2527)	4.5 (9.9)
DN50 PN100 A, 316L, flange EN 1092-1	5.5 (12.1)
DN50 PN100 B2, 316L, flange EN 1092-1	5.5 (12.1)
DN65 PN25/40 A316L, flange EN 1092-1 (DIN 2527 B)	4.3 (9.5)
DN80 PN10/16 B1316L, flange EN 1092-1 (DIN 2527 C)	4.8 (10.6)
DN80 PN25/40 A316L, flange EN 1092-1 (DIN 2527 B)	5.9 (13)
DN80 PN25/40 B1316L, flange EN 1092-1 (DIN 2527 C)	5.2 (11.5)
DN80 PN40 B1, 316L, flange EN 1092-1 (DIN 2526 D)	5.2 (11.5)
DN80 PN25/40 B1, AlloyC22 >1.4462, flange EN 1092-1 (DIN 2527)	5.2 (11.5)
DN80 PN63 A, 316Ti, flange EN 1092-1 (DIN 2527 B)	6.9 (15.2)
DN80 PN63 B2, 316L, flange EN 1092-1 (DIN 2527 E)	6.9 (15.2)
DN80 PN63 B1, AlloyC22 >1.4462, flange EN 1092-1 (DIN 2527)	6.9 (15.2)

Process connection: EN flanges	kg (lbs)
DN80 PN100 A, 316L, flange EN 1092-1	8.0 (17.6)
DN80 PN100 B2, 316L, flange EN 1092-1	8.0 (17.6)
DN100 PN10/16 B1, 316L, flange EN 1092-1 (DIN 2527 C)	5.3 (11.7)
DN100 PN25/40 A, 316L, flange EN 1092-1 (DIN 2527 B)	7.5 (16.5)
DN100 PN63 A, 316L, flange EN 1092-1 (DIN 2527 B)	10.1 (22.3)
DN100 PN63 B2, 316L, flange EN 1092-1 (DIN 2527 E)	10.1 (22.3)
DN100 PN63 B1, AlloyC22 >1.4462 flange EN 1092-1 (DIN 2527)	10.1 (22.3)
Process connection: ANSI flanges	kg (lbs)
1" 150 lbs RF, 316/316L, flange ANSI B16.5	1.0 (2.2)
1¼" 300 lbs RF, 316/316L, flange ANSI B16.5	2.0 (4.4)
1½" 150 lbs RF, 316/316L, flange ANSI B16.5	1.5 (3.3)
1½" 300 lbs RF, 316/316L, flange ANSI B16.5	2.7 (6.0)
2" 150 lbs RF, 316/316L, flange ANSI B16.5	2.4 (5.3)
2" 150 lbs RF, AlloyC22 >1.4462, flange ANSI B16.5	2.4 (5.3)
2" 300 lbs RF, 316/316L, flange ANSI B16.5	3.2 (7.1)
2" 300 lbs RF, AlloyC22 >1.4462, flange ANSI B16.5	3.2 (7.1)
2" 600 lbs RF, 316/316L, flange ANSI B16.5	4.2 (9.3)
2" 600 lbs RF, AlloyC22 >1.4462, flange ANSI B16.5	4.2 (9.3)
3" 150 lbs RF, 316/316L, flange ANSI B16.5	4.9 (10.8)
3" 300 lbs RF, 316/316L, flange ANSI B16.5	6.8 (15)
3" 600 lbs RF, 316/316L, flange ANSI B16.5	8.5 (18.7)
3" 600 lbs RF, AlloyC22 >1.4462, flange ANSI B16.5	8.5 (18.7)
4" 150 lbs RF, 316/316L, flange ANSI B16.5	7.0 (15.4)
4" 300 lbs RF, 316/316L, flange ANSI B16.5	11.5 (25.4)
4" 600 lbs RF, 316/316L, flange ANSI B16.5	17.3 (38.2)
Process connection: JIS flanges	kg (lbs)
20 K 50 RF, 316L, flange JIS B2220	1.9 (4.2)
20 K 50RF, AlloyC22 >316L, flange JIS B2220	1.9 (4.2)
Pipe extension	kg (lbs)
1 m	0.9 (2)
100 in	2.3 (5.1)
Weather protection cover	kg (lbs)
1 piece	0.3 (0.7)

Material

Material specifications as per AISI and DIN-EN.

Parts in contact with process in FTL80, FTL81

- Process connection and pipe extension: 316L (1.4435) optionally 2.4602 (AlloyC22)
- Tuning fork:
 - High-temperature version 318L (1.4462); optionally 2.4602 (AlloyC22)
 - Standard version 316L (1.4435); optionally 2.4602 (AlloyC22)
- Flanges: 316L (1.4435 or 1.4404)
- Flange plating: AlloyC22
 - High-temperature version carrier material 318L (1.4462)
 - Standard version carrier material 316L (1.4435 or 1.4404)
- Flat seal for process connection G ¾ or G 1: fiber-reinforced elastomer seal, asbestos-free

Parts in contact with process in FTL85

	ECTFE	PFA (Edlon™)	PFA (RubyRed)	PFA (conductive)	Enamel
Layer thickness: Lower limit	0.5 mm (0.02 in)	0.45 mm (0.02 in)	0.45 mm (0.02 in)	0.45 mm (0.02 in)	0.4 mm (0.02 in)
Layer thickness: Upper limit	1.6 mm (0.06 in)	1.6 mm (0.06 in)	1.6 mm (0.06 in)	1.6 mm (0.06 in)	0.8 mm (0.3 in)

	ECTFE	PFA (Edlon™)	PFA (RubyRed)	PFA (conductive)	Enamel
Flange carrier material	316L (1.4435 or 1.4404)	316L (1.4435 or 1.4404)	316L (1.4435 or 1.4404)	316L (1.4435 or 1.4404)	1.0487
Carrier material pipe extension	316L (1.4435 or 1.4404)	316L (1.4435 or 1.4404)	316L (1.4435 or 1.4404)	316L (1.4435 or 1.4404)	Alloy C4 (2.4610)
Tuning fork carrier material:	316L (1.4435 or 1.4404)	316L (1.4435 or 1.4404)	316L (1.4435 or 1.4404)	316L (1.4435 or 1.4404)	Alloy C4 (2.4610)

Parts with no process contact

- Seal between process connection and housing: EPDM
- Temperature spacer: 316L (1.4435) or 318L for plated high-temperature version
- Pressure-tight feedthrough: 316L (1.4435)
- Grounding at housing (outside): 304 (1.4301)
- Polyester housing F16: PBT-FR with PBT-FR cover or with PA12 transparent cover
 - Cover seal: EPDM
 - Nameplate glued: polyester film (PET)
 - Pressure compensation filter: PBT-GF20
- Stainless steel housing F15: 316L (1.4404)
 - Cover seal: silicone/PTFE
 - Safety claw: 304 (1.4301)
 - Pressure compensation filter: PBT-GF20, PA
 - Nameplate labeling: directly on housing
- Aluminum housing F17/F13: EN-AC-ALSi10Mg, plastic-coated
 - Cover seal: EPDM
 - Safety claw: nickel-plated brass
 - Pressure compensation filter: silicone
 - Nameplate at housing (outside): 304 (1.4301)
- Stainless steel housing F27: 316L
 - Cover seal: FVMQ (optional: EPDM seal available as spare part)
 - Safety claw: 316L
 - Nameplate at housing (outside): 304 (1.4301)
- Aluminum housing T13: EN-AC-ALSi10Mg, plastic-coated,
 - Cover seal: EPDM
 - Safety claw: nickel-plated brass
 - Nameplate at housing (outside): 304 (1.4301)
- Cable gland versions:
 - Polyamide (PA)
 - Nickel-plated brass
 - 316L (1.4435)
 - M12 connector (nickel-plated brass)

Operability

Electronic insert

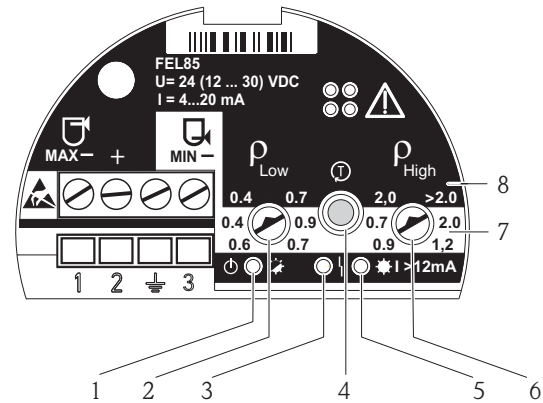

A0018032

Number	Description	Function
1	LED green, operation	Initialization (lit), Normal operation (flashing), Error (off)
2	Density ρ_{low} (rotary switch)	Setting for the lower limit of the density range
3	LED red, error	Sensor error (lit constantly), Operating error and electronic insert error (flashing)
4	Button	To confirm configuration changes and to activate the proof test
5	LED yellow, current output	MAX (exposed) lit (13.5 mA), MIN (covered) lit (18.5 mA)
6	Density ρ_{high} (rotary switch)	Setting for the upper limit of the density range
7	MIN	White background indicates configurable density range in the MIN operating mode
8	MAX	Black background indicates configurable density range in the MAX operating mode

Operating concept

- Onsite configuration
- MIN or MAX safety set via connection wiring
- Density range set via two rotary switches, confirmation via button

Certificates and approvals

CE mark, Declaration of Conformity

The devices are designed to meet state-of-the-art safety requirements, have been tested, and left the factory in a condition in which they are safe to operate. The devices comply with the applicable standards and regulations that are listed in the EC Declaration of Conformity and thus meet the legal requirements of the EC Directives. confirms the conformity of the device by affixing to it the CE mark.

Approvals

Non-hazardous area
ATEX II 1G Ex ia IIC T6 Ga
ATEX II 1/2G Ex ia IIC T6 Ga/Gb
ATEX II 1/2G Ex d IIC T6 Ga/Gb
ATEX II 1/2G Ex de IIC T6 Ga/Gb
ATEX II 1/3G Ex nA IIC T6 Ga/Gc
ATEX Ex ia G/D, ATEX II 1/2G Ex ia IIC T6 Ga/Gb, ATEX II 1/2D Ex ia IIIC Da/Db
ATEX Ex d / Ex ta, ATEX II 1/2G Ex d IIC T6 Ga/Gb, ATEX II 1/2D Ex ta IIIC Da/Db
ATEX Ex ia / Ex d, ATEX II 1/2G Ex ia IIC T6 Ga/Gb, ATEX II 1/2G Ex d IIC T6 Ga/Gb
CSA General Purpose
CSA C/US IS Cl.I,II,III Div.1 Gr.A-G T6, Cl.I Zone 0 AEx/Ex ia IIC T6 Ga, Single/DualSeal
CSA C/US NI Cl.I,II,III Div.2 Gr.A-G T6, Cl.I Zone 2 AEx/Ex nA IIC T6 Gc, Single/DualSeal
CSA C/US XP Cl.I,II,III Div.1 Gr.A-G T6, Cl.I Zone 1 AEx/Ex d IIC T6 Gb, NI Cl.I,II,III Div.2 Gr. A-G T6, Cl.I Zone 2 AEx/Ex nA IIC T6 Gc, Single/DualSeal
FM C/US IS Cl. I,II,III Div.1 Gr.A-G, Cl. I, Zone 0, AEx/Ex ia IIC T6
FM C/US NI Cl.I Div.2 Gr.A-D, T6
FM C/US XP Cl. I Div.1 Gr. A-D T6, DIP Cl. II,III Div.1 Gr. E,F,G T6, NI Cl. I Div.2 Gr. A-D T6, Cl. I, Zone 1, AEx/Ex d IIC T6, Cl. I, Zone 2 AEx/Ex nA IIC T6
FM C/US XP Cl. I Div.1 Gr. B-D T6, DIP Cl. II,III Div.1 Gr. E,F,G T6, NI Cl. I Div.2 Gr. A-D T6, Cl. I, Zone 1, AEx/Ex d IIC T6, Cl. I, Zone 2 AEx/Ex nA IIC T6
IECEX Ex ia IIC T6 Ga
IECEX Ex ia IIC T6 Ga/Gb
IECEX Ex d IIC T6 Ga/Gb
IECEX Ex de IIC T6 Ga/Gb
IECEX Ex nA IIC T6 Ga/Gc
IECEX Ex ia G/D, IECEX Ex ia IIC T6 Ga/Gb, IECEX Ex ia IIIC Da/Db
IECEX Ex d/Ex t, IECEX Ex d IIC T6 Ga/Gb, IECEX Ex t IIIC Da/Db
IECEX ia/Ex d, IECEX Ex ia IIC T6 Ga/Gb, IECEX Ex d IIC T6 Ga/Gb
NEPSI Zone 0 Ex ia IIC T6 Ga
NEPSI Zone 0/1 Ex ia IIC T6 Ga/Gb
NEPSI Zone 0/1 Ex d IIC T6 Ga/Gb
NEPSI Zone 0/1 Ex de IIC T6 Ga/Gb
NEPSI Zone 0/2 Ex nA IIC T6 Ga/Gc
TIIS Ex ia IIC T4
TIIS Ex d IIC T4
FM/CSA C/US IS+XP, IS Cl.I,II,III Div.1 Gr.A-G T6, XP Cl.I,II,III Div.1 Gr.A-G T6, Cl.I Zone 0 AEx/Ex ia IIC T6 Ga, Cl.I Zone 1 AEx/Ex d IIC T6 Gb, Single/DualSeal
ATEX/IECEX Ex ia, ATEX II 1/2G Ex ia IIC T6 Ga/Gb, IECEX Ex ia IIC T6 Ga/Gb
ATEX/IECEX Ex d, ATEX II 1/2G Ex d IIC T6 Ga/Gb, IECEX Ex d IIC T6 Ga/Gb

Other certificates

Material certificates

- EN 10204 - 3.1 material (wetted metal parts) inspection certificate
- EN 10204 - 3.1 material, NACE MR0175/MR103 (wetted metal parts) inspection certificate

WHG

- Overfill detection system: Z-65.11-507
- Leak detection system: Z-65.40-508

Marine approval

GL, ABS marine approval

Liquefied gas approval

VdTÜV100

PWIS free

PWIS = paint-wetting impairment substances, max. 2000 mm (80 in)

TSE Certificate of Suitability

The following applies for device components in contact with the process:

- They do not contain any materials derived from animals.
- No additives or operating materials derived from animals are used in production or processing.



Note!

Wetted device components are listed in the "Mechanical construction" chapters.

Tests and Certificates

- 3.1 Material certificate, wetted metallic parts, EN10204-3.1 inspection certificate
- Declaration of conformity NACE MR0175, wetted metallic parts
- Declaration of conformity NACE MR0103, auf Anfr. wetted metallic parts
- Helium leak test, internal procedure, inspection certificate
- Pressure test, internal procedure, inspection certificate
- 3.1 Material certificate + PMI test (XRF), internal procedure, wetted metallic parts, EN10204-3.1 inspection certificate
- Liquid penetrant test AD2000-HP5-3(PT), wetted/pressure retaining metallic parts, inspection certificate
- Liquid penetrant test ISO23277-1 (PT), wetted/pressure retaining metallic parts, inspection certificate
- Liquid penetrant test ASME VIII-1 (PT), wetted/pressure retaining metallic parts, inspection certificate
- Welding documentation, wetted/pressure retaining seams
- Special version, TSP-no. to be specified

CRN approval

Versions with a CRN approval (Canadian Registration Number) are listed in the corresponding registration documents.

CRN registration number: 0F10904.5CADD2

CRN-approved devices are assigned the registration number.

Process seal according to ANSI/ISA 12.27.01

Practice in North America for the installation of process seals

devices are designed as either single seal or dual seal devices with an alarm in accordance with ANSI/ISA 12.27.01. This means that the user does need to install for an external secondary process seal in the thermowell which is required in ANSI/NFPA 70 (NEC) and CSA 22.1 (CEC). These devices comply with installation practice in North America and enable very safe, low-cost installation in pressurized applications with hazardous media.

Further information is provided in the Safety Instructions (XA) for the specific device 29 ff.

Product	Type	Max. process pressure	Marking	Approval
Liquiphant FailSafe	FTL80-CB/CC/CD##...	100 bar (1450 psi)	Single Seal*	CSA
	FTL80-FB/FC/FD##...			FM
	FTL81-CB/CC/CD##...	100 bar (1450 psi)	Single Seal*	CSA
	FTL81-FB/FC/FD/FE##...			FM
	FTL85-CB/CC/CD##...	40 bar (580 psi)	Single Seal*	CSA
	FTL85-FB/FC/FD/FE##...			FM

* Dual seal device with alarm: in conjunction with the high-temperature version 230/280 °C (445/536 °F) or pressure-tight feedthrough (second line of defense).

Ordering information

Detailed ordering information is available:

- In the product configurator on the Internet site:  Select country → Instruments → Select instrument → Advanced functions: product configuration



- From you

Note! Product configurator - the tool for individual product configuration

- Up-to-date configuration data
- Direct entry of data specific to the measuring point, such as the measuring range or operating language, depending on the device
- Exclusion criteria automatically checked
- Automatic order code generation with code breakdown output in PDF or Excel format
- Possible to order directly in the

Accessories

Sliding sleeves for unpressurized operation

For continuous adjustment of the switch point of a Liquiphant FailSafe FTL81.

Material: corrosion-resistant steel
1.4435 (AISI 316 L)

Weight for G 1, NPT 1: 0.21 kg (0.46 lbs)
Weight for G 1½, NPT 1½: 0.54 kg (1.2 lbs)

A: SW41
B: SW55
C: 0 bar

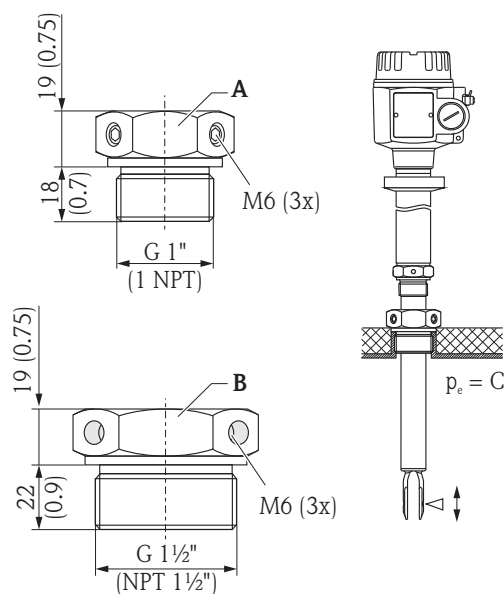

A0018222

Thread	Standard	Material	Order number	Approval
G 1	DIN ISO 228/1	1.4435 (AISI 316 L)	52003978	
G 1	DIN ISO 228/1	1.4435 (AISI 316 L)	52011888	3.1 inspection certificate EN 10204 - 3.1 material
NPT1	ANSI B 1.20.1	1.4435 (AISI 316 L)	52003979	
NPT1	ANSI B 1.20.1	1.4435 (AISI 316 L)	52011889	3.1 inspection certificate EN 10204 - 3.1 material
G 1½	DIN ISO 228/1	1.4435 (AISI 316 L)	52003980	
G 1½	DIN ISO 228/1	1.4435 (AISI 316 L)	52011890	3.1 inspection certificate EN 10204 - 3.1 material
NPT1½	ANSI B 1.20.1	1.4435 (AISI 316 L)	52003981	
NPT1½	ANSI B 1.20.1	1.4435 (AISI 316 L)	52011891	3.1 inspection certificate EN 10204 - 3.1 material

High pressure sliding sleeves

For continuous adjustment of the switch point of a Liquiphant FTL81.
 Also for use in hazardous areas. Additional information → 29+. (ATEX, NEPSI).

Material: corrosion-resistant steel 1.4435 (AISI 316L) or AlloyC22

Weight for G 1, NPT 1: 1.13 kg (2.5 lbs)
 Weight for G 1½, NPT 1½: 1.32 kg (2.9 lbs)

Seal package made of graphite

A: SW50
 B: max. 100 bar (1450 psi)

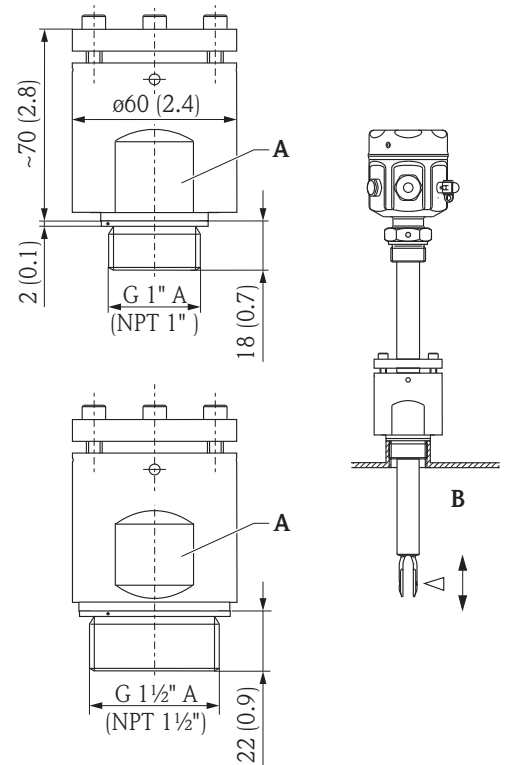

A0018223

Thread	Standard	Material	Order number	Approval
G 1	DIN ISO 228/1	1.4435 (AISI 316 L)	52003663	
G 1	DIN ISO 228/1	1.4435 (AISI 316 L)	52011880	With inspection certificate EN 10204 - 3.1 material
G 1	DIN ISO 228/1	AlloyC22	71118691	With inspection certificate EN 10204 - 3.1 material
NPT1	ANSI B 1.20.1	1.4435 (AISI 316 L)	52003667	
NPT1	ANSI B 1.20.1	1.4435 (AISI 316 L)	52011881	With inspection certificate EN 10204 - 3.1 material
NPT1	ANSI B 1.20.1	AlloyC22	71118694	With inspection certificate EN 10204 - 3.1 material
G 1½	DIN ISO 228/1	1.4435 (AISI 316 L)	52003665	
G 1½	DIN ISO 228/1	1.4435 (AISI 316 L)	52011882	With inspection certificate EN 10204 - 3.1 material
G 1½	DIN ISO 228/1	AlloyC22	71118693	With inspection certificate EN 10204 - 3.1 material
NPT1½	ANSI B 1.20.1	1.4435 (AISI 316 L)	52003669	
NPT1½	ANSI B 1.20.1	1.4435 (AISI 316 L)	52011883	With inspection certificate EN 10204 - 3.1 material
NPT1½	ANSI B 1.20.1	AlloyC22	71118695	With inspection certificate EN 10204 - 3.1 material

Pressure and temperature derating of the high pressure sliding sleeves

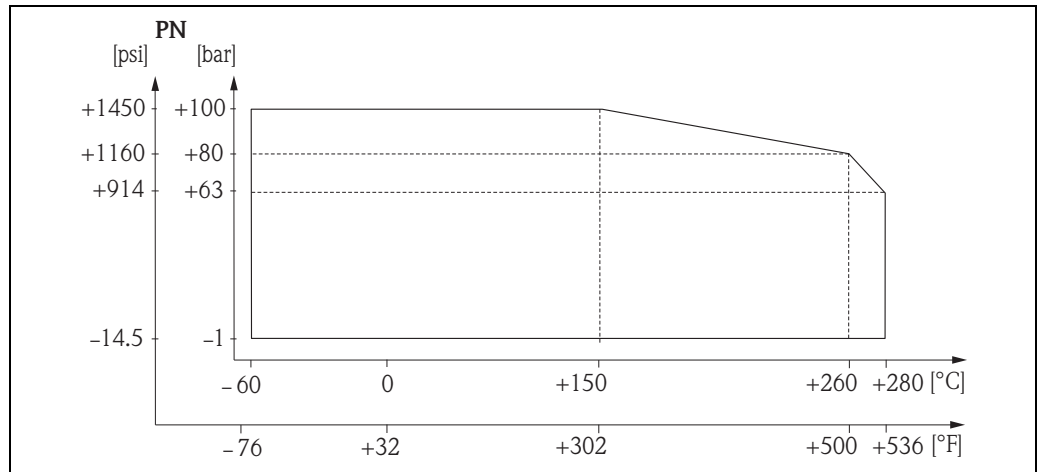

A0018224

Weather protection cover

For F16 housing

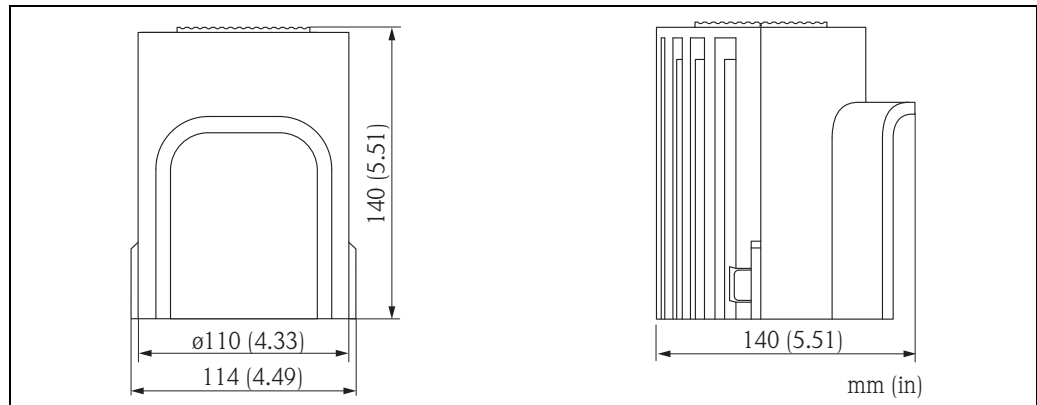

A0018225

Material	Order No.	Weight
PBT, gray	71127760	240 g (8.46 oz)

For F13, F17 and F27 housing

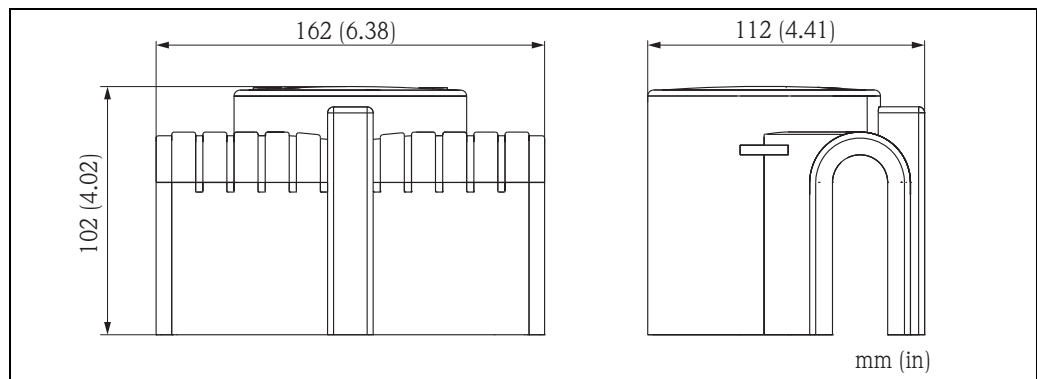

A0018226

Material	Order No.	Weight
PA6, gray	71040497	300 g (10.58 oz)

По вопросам продаж и поддержки обращайтесь:

Алматы (7273)495-231
Ангарск (3955)60-70-56
Архангельск (8182)63-90-72
Астрахань (8512)99-46-04
Барнаул (3852)73-04-60
Белгород (4722)40-23-64
Благовещенск (4162)22-76-07
Брянск (4832)59-03-52
Владивосток (423)249-28-31
Владикавказ (8672)28-90-48
Владимир (4922)49-43-18
Волгоград (844)278-03-48
Вологда (8172)26-41-59
Воронеж (473)204-51-73
Екатеринбург (343)384-55-89

Иваново (4932)77-34-06
Ижевск (3412)26-03-58
Иркутск (395)279-98-46
Казань (843)206-01-48
Калининград (4012)72-03-81
Калуга (4842)92-23-67
Кемерово (3842)65-04-62
Киров (8332)68-02-04
Коломна (4966)23-41-49
Кострома (4942)77-07-48
Краснодар (861)203-40-90
Красноярск (391)204-63-61
Курск (4712)77-13-04
Курган (3522)50-90-47
Липецк (4742)52-20-81

Магнитогорск (3519)55-03-13
Москва (495)268-04-70
Мурманск (8152)59-64-93
Набережные Челны (8552)20-53-41
Нижний Новгород (831)429-08-12
Новокузнецк (3843)20-46-81
Ноябрьск (3496)41-32-12
Новосибирск (383)227-86-73
Омск (3812)21-46-40
Орел (4862)44-53-42
Оренбург (3532)37-68-04
Пенза (8412)22-31-16
Петрозаводск (8142)55-98-37
Псков (8112)59-10-37
Пермь (342)205-81-47

Ростов-на-Дону (863)308-18-15
Рязань (4912)46-61-64
Самара (846)206-03-16
Санкт-Петербург (812)309-46-40
Саратов (845)249-38-78
Севастополь (8692)22-31-93
Саранск (8342)22-96-24
Симферополь (3652)67-13-56
Смоленск (4812)29-41-54
Сочи (862)225-72-31
Ставрополь (8652)20-65-13
Сургут (3462)77-98-35
Сыктывкар (8212)25-95-17
Тамбов (4752)50-40-97
Тверь (4822)63-31-35

Тольятти (8482)63-91-07
Томск (3822)98-41-53
Тула (4872)33-79-87
Тюмень (3452)66-21-18
Ульяновск (8422)24-23-59
Улан-Удэ (3012)59-97-51
Уфа (347)229-48-12
Хабаровск (4212)92-98-04
Чебоксары (8352)28-53-07
Челябинск (351)202-03-61
Череповец (8202)49-02-64
Чита (3022)38-34-83
Якутск (4112)23-90-97
Ярославль (4852)69-52-93

Россия +7(495)268-04-70

Казахстан +7(7172)727-132

Киргизия +996(312)96-26-47

эл.почта: ehr@nt-rt.ru || сайт: <https://endcounters.nt-rt.ru/>