

# Сигнализаторы потока Flowphant T DTT31, DTT35

## Техническая информация

По вопросам продаж и поддержки обращайтесь:

Алматы (7273)495-231  
Ангарск (3955)60-70-56  
Архангельск (8182)63-90-72  
Астрахань (8512)99-46-04  
Барнаул (3852)73-04-60  
Белгород (4722)40-23-64  
Благовещенск (4162)22-76-07  
Брянск (4832)59-03-52  
Владивосток (423)249-28-31  
Владикавказ (8672)28-90-48  
Владимир (4922)49-43-18  
Волгоград (844)278-03-48  
Вологда (8172)26-41-59  
Воронеж (473)204-51-73  
Екатеринбург (343)384-55-89

Иваново (4932)77-34-06  
Ижевск (3412)26-03-58  
Иркутск (395)279-98-46  
Казань (843)206-01-48  
Калининград (4012)72-03-81  
Калуга (4842)92-23-67  
Кемерово (3842)65-04-62  
Киров (8332)68-02-04  
Коломна (4966)23-41-49  
Кострома (4942)77-07-48  
Краснодар (861)203-40-90  
Красноярск (391)204-63-61  
Курск (4712)77-13-04  
Курган (3522)50-90-47  
Липецк (4742)52-20-81

Магнитогорск (3519)55-03-13  
Москва (495)268-04-70  
Мурманск (8152)59-64-93  
Набережные Челны (8552)20-53-41  
Нижегород (831)429-08-12  
Новокузнецк (3843)20-46-81  
Ноябрьск (3496)41-32-12  
Новосибирск (383)227-86-73  
Омск (3812)21-46-40  
Орел (4862)44-53-42  
Оренбург (3532)37-68-04  
Пенза (8412)22-31-16  
Петрозаводск (8142)55-98-37  
Псков (8112)59-10-37  
Пермь (342)205-81-47

Ростов-на-Дону (863)308-18-15  
Рязань (4912)46-61-64  
Самара (846)206-03-16  
Санкт-Петербург (812)309-46-40  
Саратов (845)249-38-78  
Севастополь (8692)22-31-93  
Саранск (8342)22-96-24  
Симферополь (3652)67-13-56  
Смоленск (4812)29-41-54  
Сочи (862)225-72-31  
Ставрополь (8652)20-65-13  
Сургут (3462)77-98-35  
Сыктывкар (8212)25-95-17  
Тамбов (4752)50-40-97  
Тверь (4822)63-31-35

Тольятти (8482)63-91-07  
Томск (3822)98-41-53  
Тула (4872)33-79-87  
Тюмень (3452)66-21-18  
Ульяновск (8422)24-23-59  
Улан-Удэ (3012)59-97-51  
Уфа (347)229-48-12  
Хабаровск (4212)92-98-04  
Чебоксары (8352)28-53-07  
Челябинск (351)202-03-61  
Череповец (8202)49-02-64  
Чита (3022)38-34-83  
Якутск (4112)23-90-97  
Ярославль (4852)69-52-93

Россия +7(495)268-04-70

Казахстан +7(7172)727-132

Киргизия +996(312)96-26-47

эл.почта: [ehr@nt-rt.ru](mailto:ehr@nt-rt.ru) || сайт: <https://endcounters.nt-rt.ru/>

# Technical Information

## Flowphant T DTT31, DTT35

Flow switch for the safe and reliable monitoring of mass flow rates and temperature in industrial processes



### Applications

Flow switch for monitoring and displaying the relative mass flow rates of liquid media in the range from 0.03 to 3 m/s (0.1 to 9.84 ft/s):

- Flowphant T DTT31 – with threaded connections or compression fitting
- Flowphant T DTT35 – with process connections for hygienic applications

### Applications:

- Monitoring of cooling water circuits of pumps, turbines, compressors and heat exchangers
- Monitoring of pump functions
- Leak monitoring in process pipes
- Monitoring of lubrication circuits
- Filter monitoring in the beverages industry

### Your benefits

The compact flow switch impresses with state-of-the-technology:

- Virtually zero pressure loss
- FieldCare for quick configuration and reliable storage of device settings
- Optional: Second switch output or 4 to 20 mA analog output for temperature monitoring or to output the flow as a percentage value
- Onsite function check and process information with digital display on device
- 310° rotatable top housing section and rotatable display allow measured values to be read in all installation positions
- Marine approval
- 3-A mark and EHEDG certificate for DTT35

## Table of contents

<b>Function and system design</b> . . . . .	<b>3</b>	DTT35 design, dimensions of process connections . . . . .	15
Measuring principle . . . . .	3	Weight . . . . .	15
Measuring system . . . . .	3	Materials . . . . .	16
<b>Input</b> . . . . .	<b>5</b>	<b>Operability</b> . . . . .	<b>17</b>
Measured variable . . . . .	5	Operating concept . . . . .	17
Measuring range . . . . .	5	Local operation . . . . .	17
<b>Output</b> . . . . .	<b>5</b>	Remote operation with PC . . . . .	19
Output signal . . . . .	5	<b>Certificates and approvals</b> . . . . .	<b>20</b>
Signal on alarm . . . . .	5	CE mark . . . . .	20
Load . . . . .	5	Other standards and guidelines . . . . .	20
Range of adjustment . . . . .	5	UL approval . . . . .	20
Switching capacity . . . . .	5	Hygiene standard . . . . .	20
Inductive load . . . . .	6	Materials in contact with food/product (FCM) . . . . .	20
<b>Power supply</b> . . . . .	<b>6</b>	Marine approval . . . . .	20
Electrical connection . . . . .	6	Material certification . . . . .	20
Supply voltage . . . . .	7	<b>Ordering information</b> . . . . .	<b>20</b>
Current consumption . . . . .	7	<b>Accessories</b> . . . . .	<b>22</b>
<b>Performance characteristics</b> . . . . .	<b>7</b>	Device-specific accessories . . . . .	22
Reference operating conditions . . . . .	7	Communication-specific accessories . . . . .	23
Maximum measured error . . . . .	7	<b>Supplementary documentation</b> . . . . .	<b>24</b>
Switch point non-reproducibility . . . . .	9	Technical Information . . . . .	24
Temperature gradient . . . . .	9	Operating Instructions . . . . .	24
Sensor response time . . . . .	9		
Long-term drift . . . . .	9		
Long-term reliability . . . . .	9		
Switch output response time . . . . .	9		
Analog output . . . . .	9		
<b>Installation</b> . . . . .	<b>10</b>		
Orientation . . . . .	10		
Installation instructions . . . . .	10		
Inlet and outlet runs . . . . .	11		
<b>Environment</b> . . . . .	<b>12</b>		
Ambient temperature range . . . . .	12		
Storage temperature . . . . .	12		
Operating altitude . . . . .	12		
Degree of protection . . . . .	12		
Shock resistance . . . . .	12		
Vibration resistance . . . . .	12		
Electromagnetic compatibility (EMC) . . . . .	12		
Electrical safety . . . . .	12		
<b>Process</b> . . . . .	<b>12</b>		
Process temperature range . . . . .	12		
Process pressure range . . . . .	13		
Flow limit . . . . .	13		
Operational range . . . . .	13		
<b>Mechanical construction</b> . . . . .	<b>13</b>		
Design, dimensions . . . . .	13		
DTT31 design, dimensions of process connections . . . . .	14		

## Function and system design

### Measuring principle

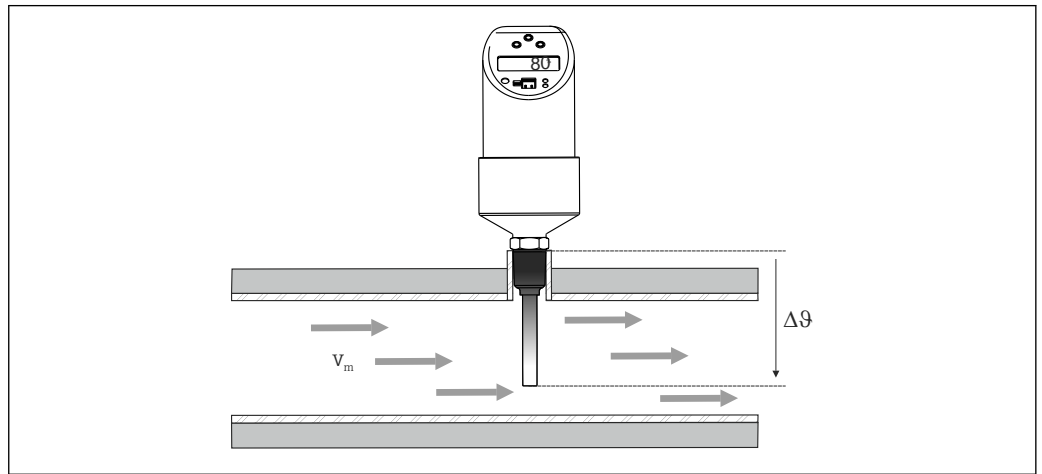

The device measures the mass flow of a liquid medium using the calorimetric measurement method. The calorimetric measuring principle is based on the cooling of a heated temperature sensor. Heat is removed from the sensor by forced convection due to medium flowing by. The extent of this heat transfer depends on the flow velocity of the medium and the difference in temperature between the sensor and the medium (King's Law). The higher the flow velocity or the mass flow of the medium, the greater the temperature sensor cooling.

### Measuring system

#### Overview

Flowphant product family	DTT31	DTT35
	<p>A0005276</p>	<p>A0023194</p>
Sensing element	RTD	RTD
Field of application	Monitoring of mass flow of water, water-like substances and low-viscosity oils (viscosity: 0.184 to 20 mPa·s; thermal conductivity: 29 to 688 mW/m·K). Example: aqueous solution monoethylene glycol (20 vol%) at 20 °C: viscosity: 1.65 mPa·s; thermal conductivity: 512 mW/mK	Monitoring of mass flow of liquid media in hygienic processes (viscosity: 0.184 to 20 mPa·s; thermal conductivity: 29 to 688 mW/mK). Example: aqueous solution monoethylene glycol (20 °C vol%) at 20 °C: viscosity: 1.65 mPa·s; thermal conductivity: 512 mW/mK

Flowphant product family	DTT31	DTT35
Process connection	<ul style="list-style-type: none"> <li>▪ Compression fitting</li> <li>▪ Thread: <ul style="list-style-type: none"> <li>▪ G<math>\frac{1}{2}</math>" and G<math>\frac{3}{4}</math>"</li> <li>▪ ANSI NPT<math>\frac{1}{4}</math>" and NPT<math>\frac{1}{2}</math>"</li> </ul> </li> </ul>	Hygiene: <ul style="list-style-type: none"> <li>▪ Conical metal-metal G<math>\frac{1}{2}</math>"</li> <li>▪ Clamp 1" - 1<math>\frac{1}{2}</math>", 2"</li> <li>▪ Varivent F, N</li> <li>▪ DIN 11851</li> <li>▪ APV Inline</li> </ul>
Measuring range	Mass flow as a relative value from 0 to 100%. Process measuring limit for liquids: 0.03 to 3 m/s (0.1 to 9.84 ft/s)	

### DC voltage version (DC)

PNP switch output of electronics.

Power supply e.g. with a power supply unit.

Preferably in connection with programmable logic controllers (PLC) or for controlling a relay.

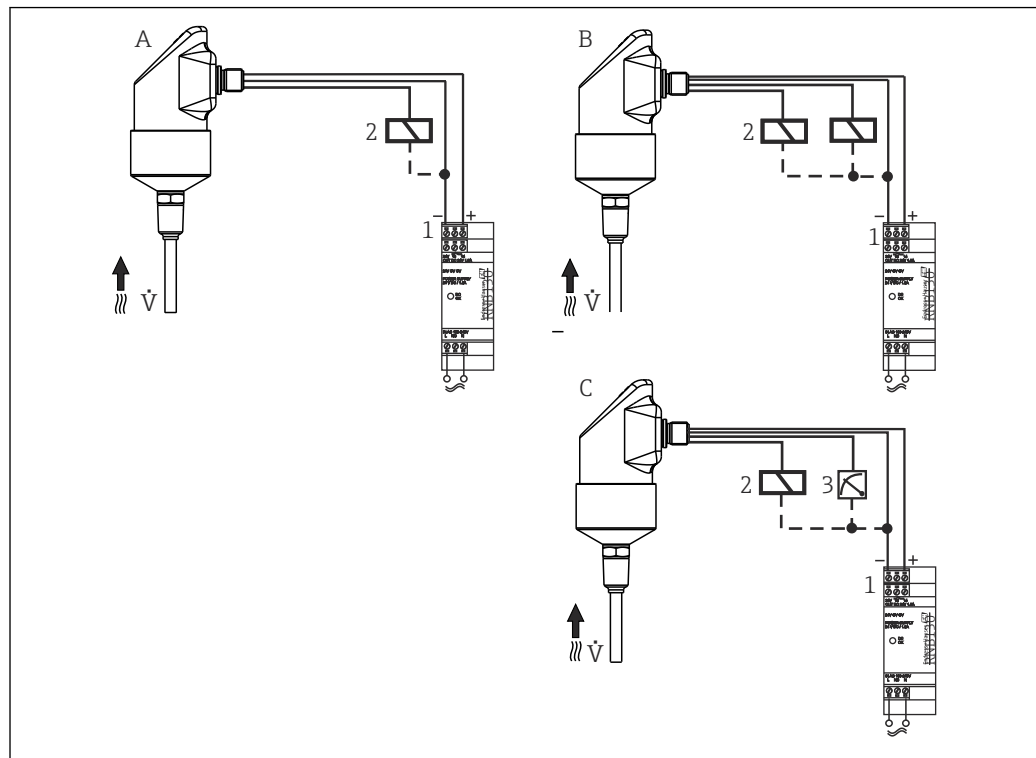

A0005373

- A 1x PNP switch output  
 B 2x PNP switch output  
 C PNP switch output with additional analog output 4 to 20 mA (active)  
 1 Transmitter power supply unit, e.g. RNB130  
 2 Load (e.g. programmable logic controller, process control system, relay)  
 3 Indicator, e.g. RIA452, or recorder, e.g. Ecograph T, (at the 4 to 20 mA analog output)

### 1 "Easy Analog RNB130" transmitter power supply

Primary switched-mode power supply for sensors. Space-saving DIN rail mounting as per IEC 60715. Wide-range input: 100 to 240 V<sub>AC</sub> nominal voltage; output: 24 V<sub>DC</sub>, max. 30 V in the event of a fault;

Nominal current: 1.5 A. Connection to single-phase alternating current networks or to two phase conductors of three-phase supply networks.

### 2 Process Indicator RIA452

If you would like to read off the instantaneous temperature value not only locally, but also directly from a control room or in the PC network, for example, the process indicator RIA452 is one possible solution: digital process indicator in 96 to 96 mm (3.78 to 3.78 in) panel-mounted housing for

monitoring and displaying analog measured values with pump control and batch functions. Multicolored 7-digit 14-segment LC display with bargraph representation. Configuration and measured value visualization via RS232 interface and PC configuration software.

### 3 Universal Graphic Data Manager Ecograph T

If you would not only like to read off the instantaneous temperature value, but also record, analyze and display it directly in a control room or in the PC network, for example, then the following options are available:

Ecograph T Universal Graphic Data Manager in the 144 mm (5.67 in) x 144 mm (5.67 in) panel-mounted housing for the electronic capture, display, recording, analysis, remote transmission and archiving of analog and digital input signals. Multichannel data recording system with multicolored TFT display (145 mm (5.7 in) screen size), galvanically isolated universal inputs (U, I, TC, RTD, pulse, frequency), digital inputs, transmitter power supply, limit relays, communication interfaces (USB, Ethernet, optionally RS232/485), 128 MB internal memory, external SD card and USB stick. The Field Data Manager (FDM) software supports data analysis at the PC, the device can be configured with FieldCare or the integrated Web server.

## Input

### Measured variable

- Flow velocity of liquid media (calorimetric measuring principle)
- Temperature (RTD), optionally for two switch outputs or additional analog output

### Measuring range

<b>Flow</b>	0.03 to 3 m/s (0.1 to 9.84 ft/s), as relative value between 0 to 100%; maximum display resolution: 1%
<b>Temperature</b>	-20 to +85 °C (-4 to +185 °F); display resolution: 1 °C (1 °F)

## Output

### Output signal

DC voltage version (short-circuit proof version):

- 1x PNP switch output (flow) or
- 2x PNP switch outputs (flow or temperature, configurable) or
- 1x PNP switch output and 1x 4 to 20 mA output, active (flow or temperature, configurable)

 The analog output reports the measured flow as a relative value expressed as a percentage of the set measuring range.

### Signal on alarm

Analog output: signal on alarm according to NAMUR NE43

<b>Underranging</b>	Linear drop to 3.8 mA
<b>OVERRANGING</b>	Linear rise to 20.5 mA
<b>Sensor breakage; sensor short-circuit</b>	≤3.6 mA or ≥ 21.0 mA (output 21.7 mA is guaranteed for setting ≥ 21.0 mA)
<b>Switch outputs</b>	In the safe state (switch open)

### Load

Max.  $(V_{\text{power supply}} - 6.5 \text{ V}) / 0.022 \text{ A}$  (current output)

### Range of adjustment

<b>Switch output</b>	Switch point (SP) and switchback point (RSP) in increments of 1% with min. hysteresis of 5%
<b>Damping</b>	User-configurable 0 = off (no damping) or 10 to 40 s in increments of 1 s
<b>Unit</b>	%, optionally °C, °F (with two outputs and temperature monitoring)

### Switching capacity

DC voltage version:

<b>Switch status ON</b>	$I_a \leq 250 \text{ mA}$
<b>Switch status OFF</b>	$I_a \leq 1 \text{ mA}$
<b>Switching cycles</b>	$> 10,000,000$
<b>Voltage drop PNP</b>	$\leq 2 \text{ V}$
<b>Overload protection</b>	Switching current checked automatically; switched off in event of overcurrent, switching current checked again every 0.5 s; max. capacitive load: 14 $\mu\text{F}$ for max. supply voltage (without resistive load); periodic disconnection from a protective circuit in event of overcurrent ( $f = 2 \text{ Hz}$ ) and "Warning" displayed

**Inductive load**

To prevent electrical interference, only operate an inductive load (relays, contactors, solenoid valves) with a direct protective circuit (free-wheeling diode or capacitor).

## Power supply

**Electrical connection**

**Plug connector**

**i** DTT35: According to the 3-A Sanitary Standard and EHEDG electrical connecting cables must be smooth, corrosion-resistant and easy to clean.

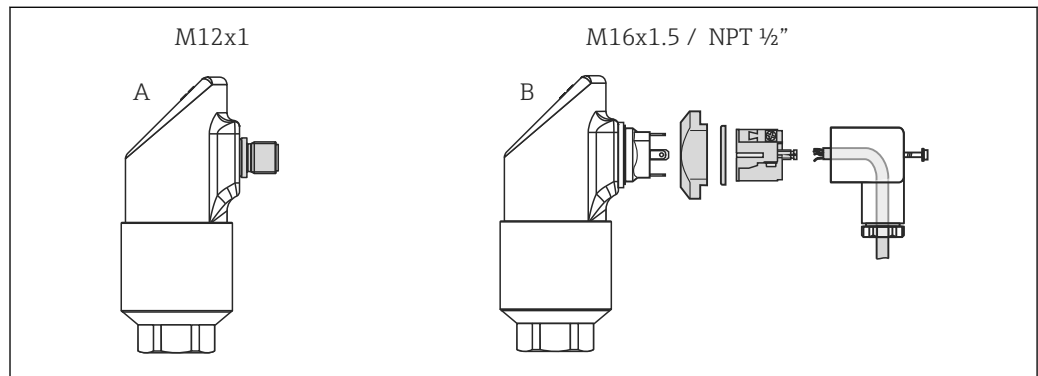

A0023196

- A M12x1 connector
- B Valve connector M16x1.5 or NPT 1/2"

**Device connection**

DC voltage version with M12x1 connector

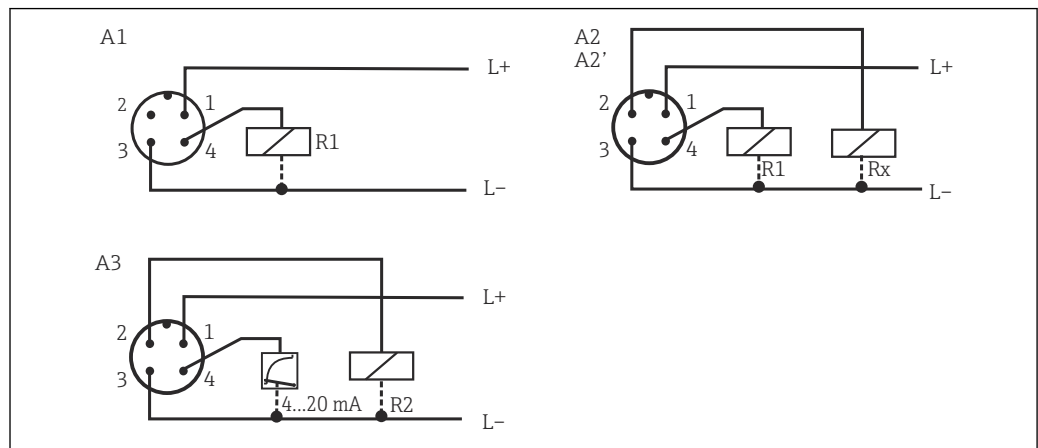

A0006818

**1** Flowphant T with M12x1 connector

Item no.	Output setting
A1	1x PNP switch output
A2	A2 2x PNP switch output R1 and Rx (R2)
A2'	2x PNP switch output R1 and Rx (diagnostics/NC contact with "DESINA" setting)
A3	1x PNP switch output and 1x analog output (4 to 20 mA)

DC voltage version with M16x1.5 valve connector or NPT 1/2"

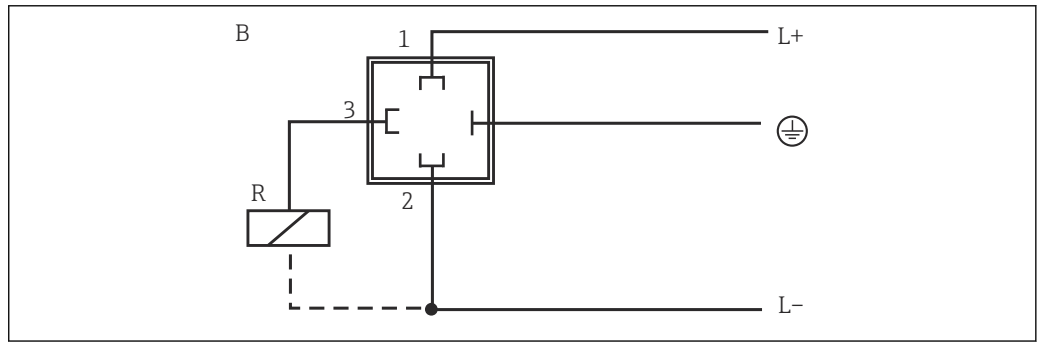

A0035798

Item no.	Output setting
B	1x PNP switch output

**Supply voltage**

DC voltage version: 18 to 30 V<sub>DC</sub> (reverse polarity protection)

Behavior in the event of overvoltage (>30 V)

- The device works continuously up to 34 V<sub>DC</sub> without any damage
- No damage in event of transient overvoltage up to 1 kV (according to EN 61000-4-5)
- If the supply voltage is exceeded, the specified characteristics are no longer guaranteed

Behavior in the event of undervoltage

If the supply voltage falls below the minimum value, the device switches off in a defined manner (status as if not supplied with power = switch open)

 The device may be powered only by a power supply unit that operates using a limited energy circuit in accordance with UL/EN/IEC 61010-1, Section 9.4 and the requirements in Table 18.

**Current consumption**

< 100 mA (no-load) at 24 V<sub>DC</sub>, max. 150 mA (no-load); with reverse polarity protection

**Performance characteristics**

The percentages in the "Performance characteristics" section refer to the full scale value or the set maximum value (100% value) of the monitoring range.

**Reference operating conditions**

As per DIN IEC 60770 or DIN IEC 61003

T = 25 °C (77 °F) ± 5 °C (9 °F)

- Relative humidity 45 to 75%
- Ambient air pressure 860 to 1 060 kPa (124 to 153 psi), water testing medium
- Supply voltage U = 24 V<sub>DC</sub>

**Maximum measured error**

**Flow**

The device records flow velocities relatively in relation to a set flow monitoring range (0 to 100 % as the display value). Absolute measurement of the flow velocity or the mass flow is not possible. The sensitivity of the calorimetric flow sensor changes with the flow velocity of the medium. It increases with decreasing flow velocity (example: in the case of water, the greatest sensor sensitivity is in the range from 0.03 to 0.5 m/s).



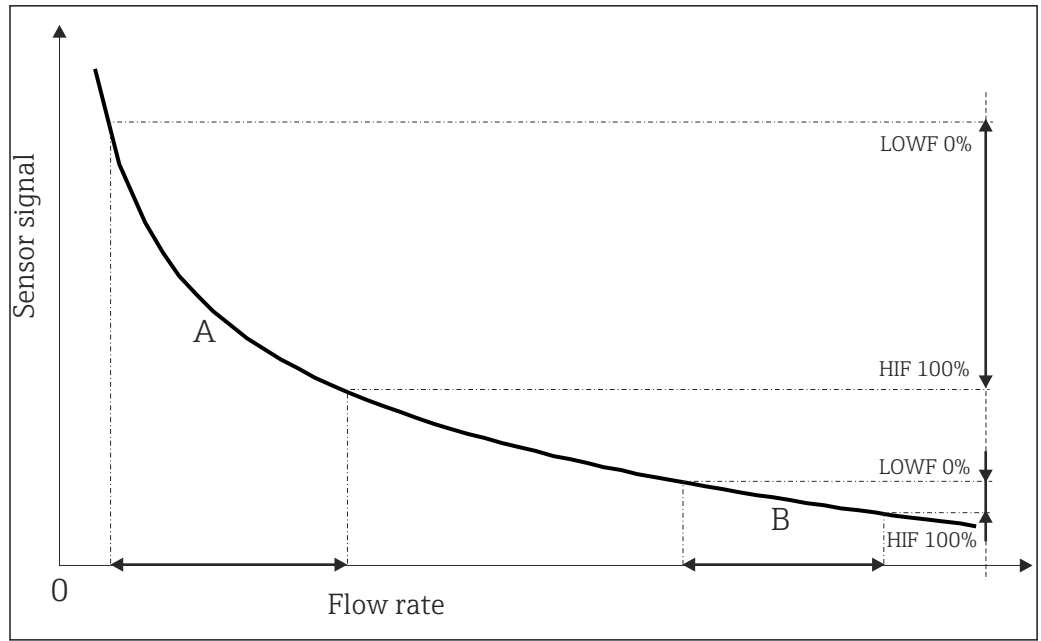

2 Standard characteristic

A, B Configured flow monitoring ranges (example)

LOWF 0%: Setting for the minimum flow velocity occurring in monitoring range A or B (0% value)

HIF 100%: Setting for the maximum flow velocity occurring in monitoring range A or B (100% value)

#### Temperature

- Accuracy 2 K (3.6 °F)
- Reproducibility 1 K (1.8 °F)
- Influence of ambient temperature 0.05%/K of full scale value

**Switch point non-reproducibility**



The values indicated only apply to the device itself without factoring in the temperature-dependent change in the thermophysical properties of the medium. For this reason, it is advisable to commission the device and set the switch points at the process temperature  
→ 17

Measuring range (water as medium)	% of maximum value	Influence of medium temperature	Influence of ambient temperature
0.03 to 0.5 m/s (0.1 to 1.6 ft/s)	≤ 2 % <sup>1)</sup>	0.05 %/K	0.04 %/K
0.03 to 1 m/s (0.1 to 3.28 ft/s)	≤ 3 % <sup>2)</sup>	0.10 %/K	0.05 %/K
0.03 to 2 m/s (0.1 to 6.56 ft/s)	≤ 5 % <sup>2)</sup>	0.15 %/K	0.10 %/K
0.03 to 3 m/s (0.1 to 9.84 ft/s)	≤ 10 % <sup>2)</sup>	0.20 %/K	0.30 %/K

1) For a Reynolds number > 10,000

**Temperature gradient**

If the medium experiences a temperature change of ≥ 0.5 K/min, temporary display drifts are possible which can exceed the specified non-reproducibility values of the switch point.

**Sensor response time**

6 to 12 s

**Long-term drift**

< 0.5% per year under reference operating conditions

**Long-term reliability**

Mean time between failure (MTBF) calculated according to SN29500 (at 40 °C)	
Low stress environment: < 0.1G	227 years
High stress environment: < 0.1G	48 years

**Switch output response time**

100 ms

**Analog output**

<b>Maximum measured error</b>	Switch point and display deviation + 0.1%
<b>Rise time t<sub>90</sub></b>	≤ 200 ms
<b>Settling time t<sub>99</sub></b>	≤ 500 ms

## Installation

### Orientation

No restrictions. However, self-draining in the process must be guaranteed. If there is an opening to detect leaks at the process connection, this opening must be at the lowest possible point.

### Installation instructions

- The sensor tip should be completely surrounded by the medium.
- Position the sensor tip in the area of maximum flow velocity (pipe center).
- Minimum sensor immersion length:  
 $L_i \geq 10 \text{ mm (0.4 in.)}$

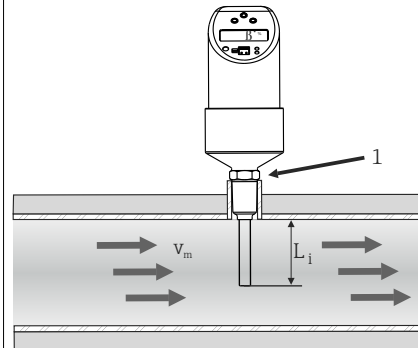

A0006976

3 Installation instructions (example)

### Orientation

- For horizontal pipes: lateral installation. Installation from above only if the pipe is completely filled with medium
- For vertical pipes: installation in the ascending pipe
- For DDT35: install at an angle of at least  $3^\circ$  to guarantee self-draining

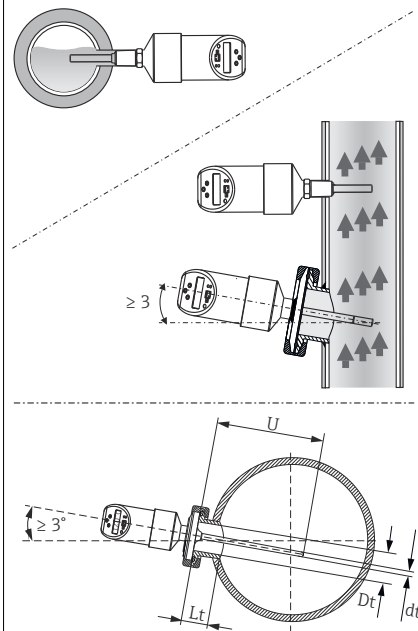

A0044425

4 Correct orientation



Do not install in down pipes open towards the end. The sensor tip should never touch the pipe wall.

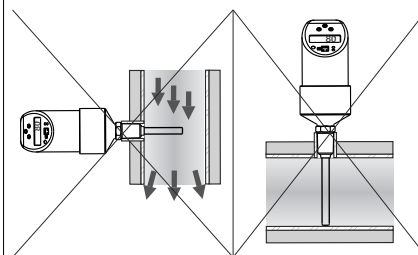

A0006978

5 Incorrect installation!

- The display can be rotated electronically by  $180^\circ$ .
- The top housing section can be rotated mechanically by up to  $310^\circ$ .

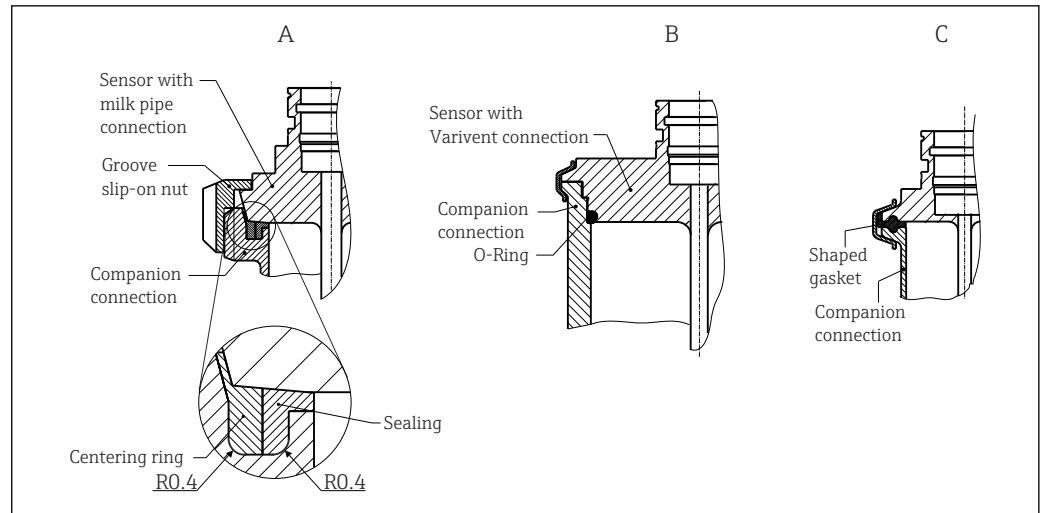

**6** Detailed installation instructions for hygiene-compliant installation

- A Milk pipe connection according to DIN 11851 (PL, PG, PH connection), only in conjunction with EHEDG-certified and self-centering sealing ring
- B Varivent® and APV-Inline (LB, LL, HL connection)
- C Clamp as per ISO 2852 (DB, DL connection), EHEDG-certified only in conjunction with seal as per EHEDG position paper

**i** The requirements of the EHEDG and the 3-A Sanitary Standard must be adhered to.

Installation instruction EHEDG/cleanability:  $Lt \leq (Dt-dt)$

Installation instruction 3-A/cleanability:  $Lt \leq 2(Dt-dt)$

In the case of weld-in connections, exercise the necessary degree of care when performing the welding work on the process side:

1. Use suitable welding material.
2. Flush-weld or weld with welding radius  $\geq 3.2$  mm (0.13 in).
3. Avoid crevices, folds or gaps.
4. Ensure the surface is honed and polished,  $Ra \leq 0.76$   $\mu\text{m}$  (30  $\mu\text{in}$ ).

Pay attention to the following when installing the thermometer to ensure that the cleanability is not affected:

1. The installed sensor is suitable for CIP (cleaning in place). Cleaning is carried out in combination with tubing/piping or tank/vessel. In the case of internal tank fixtures using process connection nozzles, it is important to ensure that the cleaning assembly sprays this area directly so that it is cleaned properly.
2. The Varivent® connections enable flush-mounted installation.

**NOTICE**

**The following action must be taken if a sealing ring (O-ring) or seal fails:**

- ▶ The thermometer must be removed.
- ▶ The thread and the O-ring joint/sealing surface must be cleaned.
- ▶ The sealing ring or seal must be replaced.
- ▶ CIP must be performed after installation.

**Inlet and outlet runs**

**i** The thermal measuring principle is sensitive to disturbed flow conditions.

- As a general rule, install the measuring device as far away as possible from any flow disturbances. For further information → ISO 14511.
- If possible, install the sensor upstream from fittings such as valves, T-pieces, elbows etc.
- To attain the specified level of accuracy of the measuring device, the inlet and outlet runs mentioned below must be maintained at the very minimum.
- If several flow disturbances are present, maintain the longest specified inlet run.

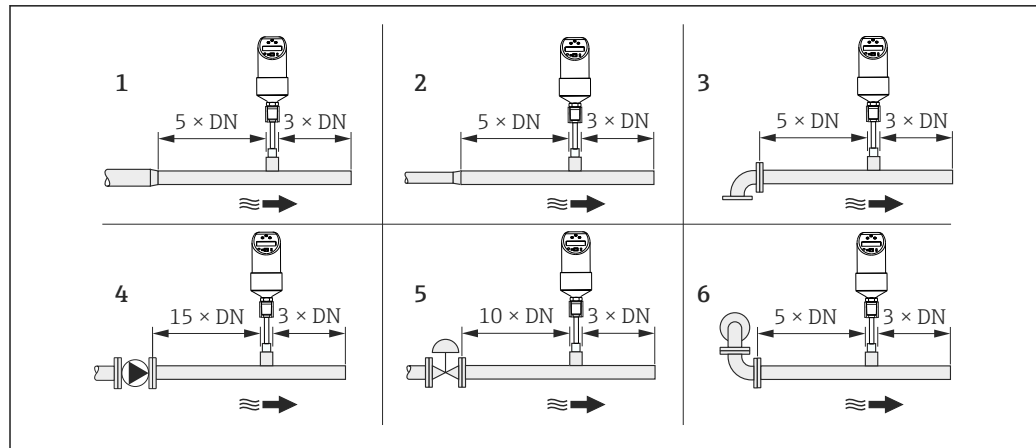

- 1 Reduction
- 2 Expansion
- 3 90° elbow or T-piece
- 4 Pump
- 5 Control valve
- 6 2x 90° elbow, 2- or 3-dimensional

## Environment

**Ambient temperature range** -40 to +85 °C (-40 to +185 °F)

**Storage temperature** -40 to +85 °C (-40 to +185 °F)

**Operating altitude** Up to 4 000 m (13 123.36 ft) above sea level

<b>Degree of protection</b>	<b>IP65</b>	M16 x 1.5 or NPT ½", valve connector
	<b>IP66</b>	M12 x 1 connector

**Shock resistance** 50 g as per DIN IEC 68-2-27 (11 ms)

**Vibration resistance**

- 20 g as per DIN IEC 68-2-6 (10-2000 Hz)
- 4 g as per marine approval

**Electromagnetic compatibility (EMC)** EMC to all relevant requirements of the IEC/EN 61326-series and NAMUR Recommendation EMC (NE21). For details, refer to the Declaration of Conformity.

Maximum fluctuations during EMC-tests: < 1 % of measuring span.

Interference immunity to IEC/EN 61326-series, requirements for industrial areas

Interference emission to IEC/EN 61326-series, electrical equipment Class B

**Electrical safety**

- Protection class III
- Overvoltage category II
- Pollution level 2

## Process

**Process temperature range** -20 to +85 °C (-4 to +185 °F)

The sensor can be exposed to process temperatures up to 130 °C (266 °F) without being damaged. The monitoring system switches off automatically at  $T \geq 85 \text{ °C}$  (185 °F) and starts again at  $T \leq 85 \text{ °C}$  (185 °F).

<b>Process pressure range</b>	Maximum permissible process pressure $P_{\max} \leq 10 \text{ MPa} = 100 \text{ bar}$ (1450 psi)  The maximum process pressure for the conical metal-metal process connection (MB option) for the device is 1.6 MPa = 16 bar (232 psi).
<b>Flow limit</b>	Liquids: 0 to 3.0 m/s (0 to 9.84 ft/s)
<b>Operational range</b>	Liquids: 0.03 to 3.0 m/s (0.1 to 9.84 ft/s)

## Mechanical construction

### Design, dimensions

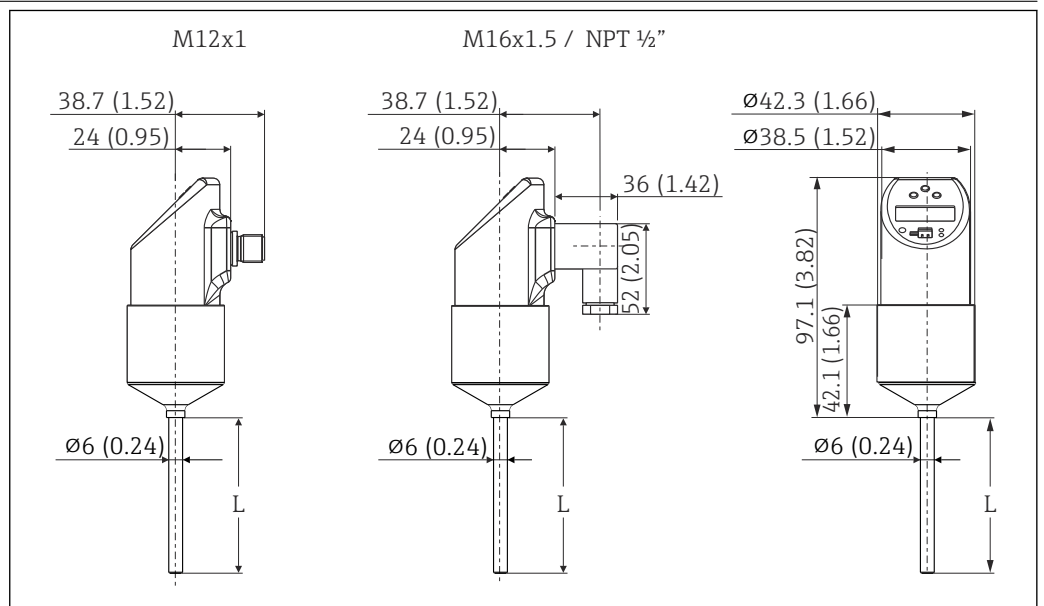

A0005279

All dimensions in mm (in)

L = insertion length

M12x1 connector as per IEC 60947-5-2

Valve connector M16x1.5 or NPT 1/2" as per DIN 43650A/ISO 4400

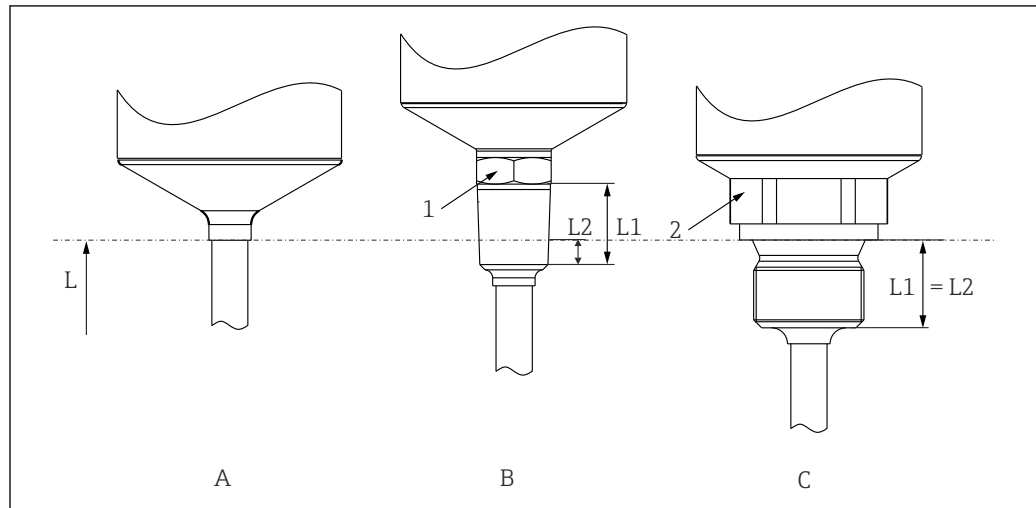
**DTT31 design, dimensions of process connections**

A0007101

**7** Process connection versions

*L* Insertion length

Item no.	Version	Thread length $L_1$	Screw-in length $L_2$
A	Without process connection. Suitable welding bosses and compression fittings. → 22	-	-
B	Threaded process connection: ANSI NPT ¼" (1 = AF14) ANSI NPT ½" (1 = AF27)	<ul style="list-style-type: none"> <li>■ 14.3 mm (0.56 in)</li> <li>■ 19 mm (0.75 in)</li> </ul>	<ul style="list-style-type: none"> <li>■ 5.8 mm (0.23 in)</li> <li>■ 8.1 mm (0.32 in)</li> </ul>
C	Threaded process connection, inches, cylindrical as per ISO 228: G ¼" (2 = AF14) G ½" (2 = AF27)	<ul style="list-style-type: none"> <li>■ 12 mm (0.47 in)</li> <li>■ 14 mm (0.55 in)</li> </ul>	-

**DTT35 design, dimensions of process connections**

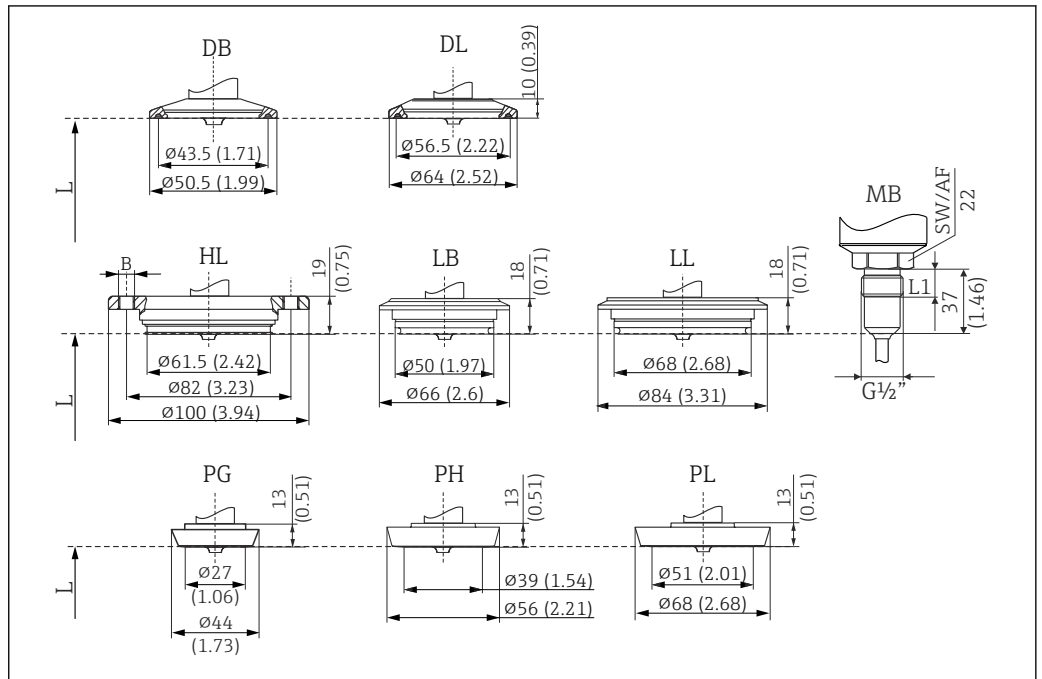

A0011776

**8** Process connection versions

All dimensions in mm (in).  
L = insertion length L

Item no.	Process connection versions DTT35	Hygiene standard
DB	Clamp 1" to 1½" (ISO 2852) or DN 25 to 40 (DIN 32676)	3-A marked and EHEDG certified (only in conjunction with self-centering seal according to EHEDG position paper)
DL	Clamp 2" (ISO 2852) or DN 50 (DIN 32676)	
HL	APV Inline, DN50, PN40, 316L, B = bores 6 x $\varnothing 8.6$ mm (0.34 in) + 2 x M8 thread	With 3-A symbol and EHEDG certification
LB	Varivent F DN25-32, PN 40, 316L	
LL	Varivent N DN40-162, PN 40, 316L	
MB	Metal sealing system for hygienic processes, $G\frac{1}{2}$ " thread, thread length $L_1 = 14$ mm (0.55 in). Suitable welding boss available as an accessory. 316L	-
PG	DIN 11851, DN25, PN40 (including coupling nut), 316L	3-A marked and EHEDG certified (only in conjunction with self-centering seal according to EHEDG position paper)
PH	DIN 11851, DN40, PN40 (including coupling nut), 316L	
PL	DIN 11851, DN50, PN40 (including coupling nut), 316L	

**i** The VARINLINE® housing connection flange is suitable for welding into the conical or torispherical head in tanks or vessels with a small diameter ( $\leq 1.6$  m (5.25 ft)) and up to a wall thickness of 8 mm (0.31 in). The Varivent type F cannot be used for installations in pipes in combination with the VARINLINE housing connection flange.

**Weight** approx. 300 g (10.58 oz), depends on process connection and sensor length



**Materials**

- Process connection AISI 316L  
Surfaces in contact with the process in hygienic version with surface quality  $R_a \leq 0.76 \mu\text{m}$  (30  $\mu\text{in}$ )
- Coupling nut AISI 304
- AISI 316L housing, with surface quality  $R_a \leq 0.76 \mu\text{m}$  (30  $\mu\text{in}$ )  
O-ring between housing and sensor module: EPDM
- Electrical connection
  - M12 connector, exterior AISI 316L, interior polyamide (PA)
  - Valve connector, polyamide (PA)
  - M12 connector, exterior 316L
  - Cable sheath polyurethane (PUR)
  - O-ring between electrical connection and housing: FKM
- Display, polycarbonate PC-FR (Lexan®)  
Seal between display and housing: SEBS THERMOPLAST K®  
Keys, polycarbonate PC-FR (Lexan®)

## Operability

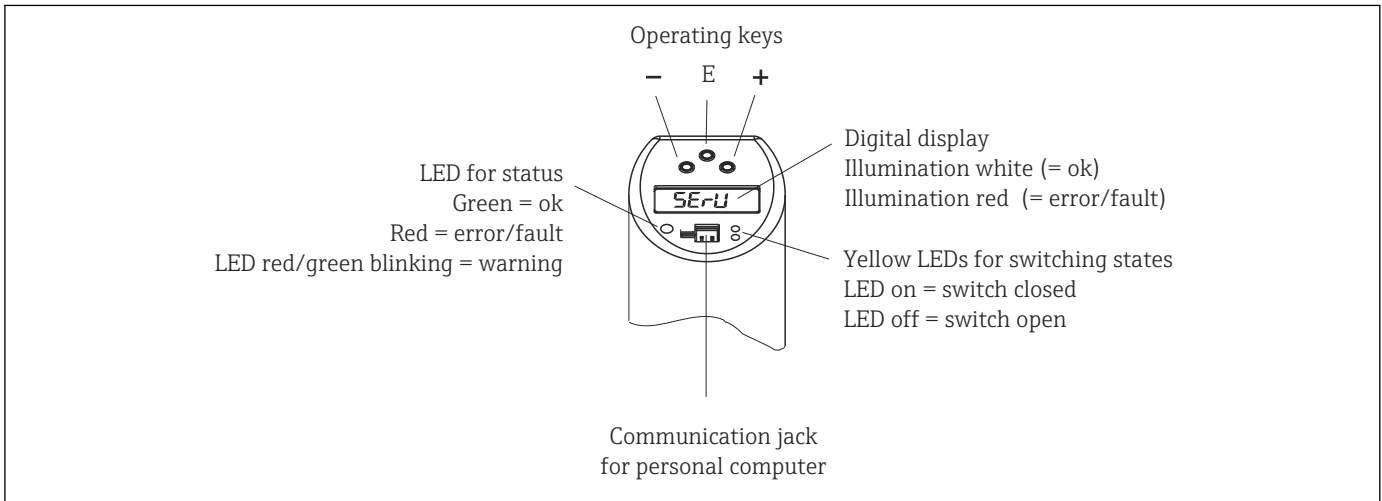

**Operating concept** Position of the display and operating elements





A0020825-EN

 To prevent damage to the keys, do not operate them with a pointed object!

**Local operation** Menu-guided operation using operating keys.

Function group	Function (display)		Description
<b>BASE</b> (basic functions)	<b>DISP</b>	Display	Display assignment: <ul style="list-style-type: none"> <li>▪ OFF</li> <li>▪ Display of current measured value or of configured switch point (switch 1)</li> <li>▪ Display of current measured value or of configured switch point (switch 1) rotated by 180°</li> <li>▪ Display of current medium temperature</li> <li>▪ Display of current medium temperature rotated by 180°</li> <li>▪ Factory setting: <b>current measured value</b></li> </ul>
	<b>UNIT</b>	Technical unit	Medium temperature displayed in the unit °C or °F Factory setting: °C  Only visible if the current medium temperature TMP is selected in the DISP mode.
	<b>TAU</b>	Damping	Measured value damping with regard to display value and output: 0 (no damping) or 9 to 40 s (in increments of 1 s) Factory setting: <b>0 s</b>
	<b>DESI</b>	DESINA Only for 2 x PNP switch outputs	Behavior as per DESINA: The PIN assignment of the M12 connector is in accordance with the DESINA Guidelines (DESINA = distributed and standardized installation technology for machine tools and manufacturing systems) Factory setting: <b>NO</b>
<b>CAL</b> Calibration	<b>HIF</b>	Learn High Flow	Setting for the maximum flow rate that occurs. 100% value
	<b>LOWF</b>	Learn Low Flow	Setting for the maximum flow rate that occurs. 0% value
Switch outputs OUT (setting for the 1st output) OUT2 (setting for the 2nd output) <b>OUT</b> Output 2	<b>MODE</b>	Switching mode	Process value for analog output: flow or temperature Factory setting: <b>flow</b>
	<b>UNIT</b>	Technical unit	Temperature unit selection (°C or °F)  Function is only visible if the switching mode MODE is set to temperature TEMP in the 2nd output. Factory setting: °C

Function group	Function (display)		Description
	<b>FUNC</b> <b>FNC2</b>	Function 1 Function 2, optional	Switch output function: Hysteresis function NC contact or NO contact (see the following diagram)
	<b>SP</b> <b>SP2</b>	Switch point Switch point 2, optional	Enter value 5 to 100% in increments of 1%, only if High and Low Flow (HIF and LOWF) have been configured beforehand. Factory setting: <b>50 %</b>  <b>or optionally for SP2:</b> Enter value -15 to +85 °C (-5 to +185 °F) in increments of 1 °C (1 °F) if the switching mode MODE is set to temperature TEMP. Factory setting: <b>55 °C</b>
	<b>SPL</b> <b>SP2L</b>	Switch point learn Switch point learn 2, optional	Take current flow rate as SP.
	<b>RSP</b> <b>RSP2</b>	Switchback point Switchback point 2, optional	Enter value 0 to 95% in increments of 1%. Factory setting: <b>40%</b>  Value must be at least 5% less than switch point 2 (SP2).  <b>or optionally for RSP2:</b> Enter value -20 to +80 °C (-4 to +176 °F) in increments of 1 °C (1 °F) if the switching mode MODE is set to temperature TEMP. Factory setting: <b>50 °C</b>  Value must be at least 5 °C (9 °F) less than switch point SP2.
	<b>TSP</b> <b>TSP2</b>	Switch point delay Switch point 2 delay, optional	Can be configured as required from 0 to 99 s in increments of 1 s Factory setting: <b>0 s</b>
	<b>TRSP</b> <b>TRSP2</b>	Switchback point delay Switchback point 2 delay, optional	Can be configured as required from 0 to 99 s in increments of 1 s Factory setting: <b>0 s</b>
Analog output 4-20 (setting for the analog output, optional)	<b>MODE</b>	Output mode	Process value for analog output: flow or temperature Factory setting: <b>flow</b>
	<b>FCUR</b>	Failure current	Specify the failure current: Choice of MIN = ≤3.6 mA MAX = ≥21.7 mA HOLD = last current value Factory setting: <b>MAX</b>
<b>SERV</b> (service functions)	<b>PRES</b>	Reset	Reset all entries to the delivery settings.
	<b>REVC</b>	Static revision counter	Configuration counter, incremented each time the configuration is changed.
	<b>LOCK</b>	Locking code	Enter the device locking code.
	<b>Code</b>	Edit locking code	Locking, only visible if the locking code is valid.
	<b>STAT</b>	Device status	
	<b>LSTA</b>	Last error	Displays the last error to occur.
Simulation: Version 2 x switch output	<b>SIMU</b> <b>SIM2</b>	Simulation 1 Simulation 2, optional	Simulation switch output 1: on/off with display, optionally corresponding to switch output 2.
Simulation: Version 1 x analog output and 1 x switch output	<b>SIM</b> <b>SIMA</b>	Simulation 1 - switch output Simulation 2 - analog output	Simulation switch output 1: on/off with display Simulation values for analog output in mA.

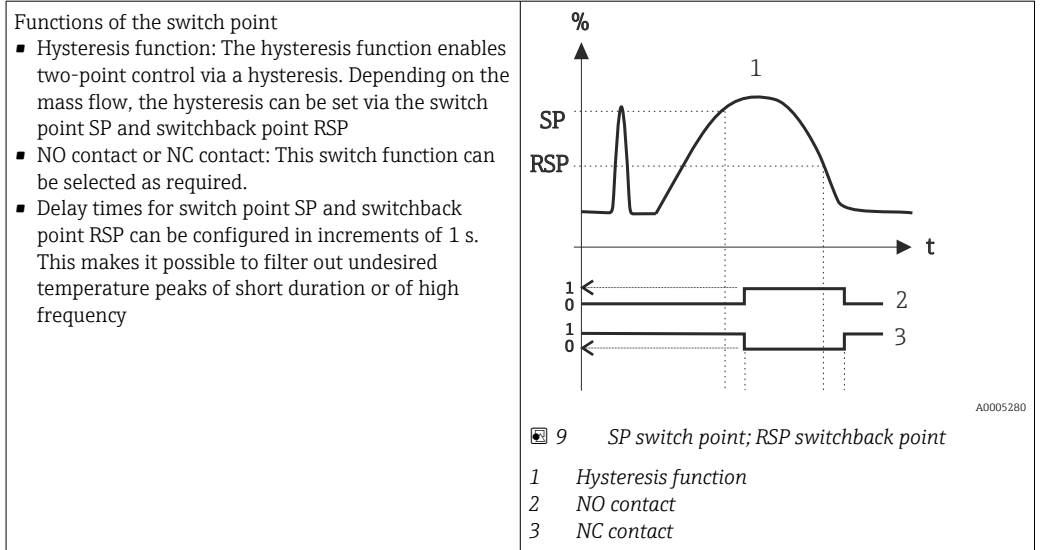

**Remote operation with PC**

Operation, visualization and maintenance with PC and FieldCare PC configuration software.

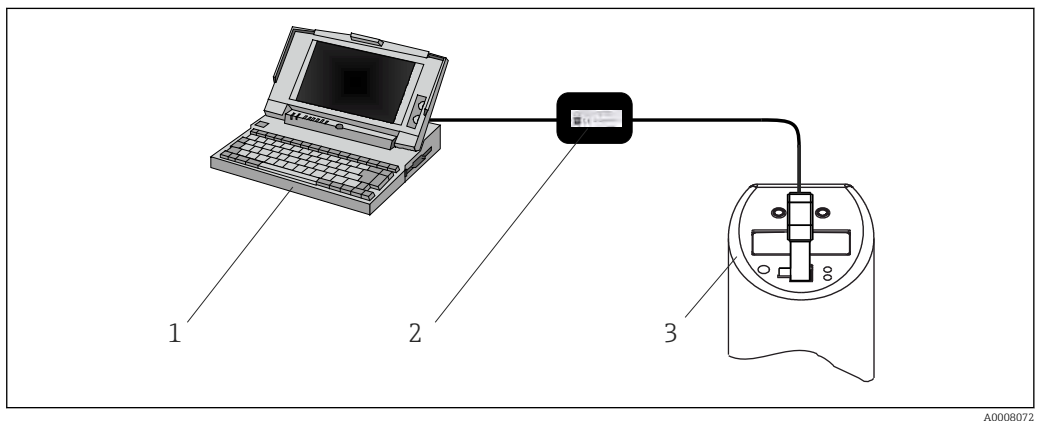

10 Operation, visualization and maintenance with PC and configuration software

- 1 PC with FieldCare configuration software
- 2 Configuration kit TXU10-AA or FXA291 with USB port
- 3 Flow switch

In addition to the operating options listed in the previous "Local operation" section, further information about the Flowphant T is available via the FieldCare configuration software:

Function group	Function (display)	Description
SERV (service function)	Switching operations 1 Switching operations 2, optional	Number of changes in the switching state for switch output 1; optionally for switch output 2
INFO (device information)	TAG 1 TAG 2, optional	Tagging, 18-digit
	Order code	Order code
	Serial number	Device serial number
	Sensor serial number	Sensor serial number
	Electronics serial number	Electronics serial number
	Device version	Displays overall version
	Hardware revision	Hardware version
	Software revision	Software version

## Certificates and approvals

<b>CE mark</b>	The product meets the requirements of the harmonized European standards. As such, it complies with the legal specifications of the EC directives. The manufacturer confirms successful testing of the product by affixing to it the CE-mark.
<b>Other standards and guidelines</b>	<ul style="list-style-type: none"> <li>■ IEC 60529: Degrees of protection provided by enclosures (IP code)</li> <li>■ IEC/EN 61010-1: Protection Measures for Electrical Equipment for Measurement, Control, Regulation and Laboratory Procedures</li> <li>■ IEC/EN 61326 series: Electromagnetic compatibility (EMC requirements)</li> <li>■ NAMUR: International user association of automation technology in process industries (</li> <li>■ NEMA: United States National Electrical Manufacturers Association.</li> </ul>
<b>UL approval</b>	More information under UL Product iq™, search for keyword "E225237")
<b>Hygiene standard</b>	<ul style="list-style-type: none"> <li>■ EHEDG certification, type EL CLASS I. EHEDG certified/tested process connections → 📄 14</li> <li>■ 3-A Authorization No. 1144, 3-A Sanitary Standard 74-07. Listed process connections → 📄 15</li> </ul>
<b>Materials in contact with food/product (FCM)</b>	<p>The materials of the thermometer in contact with food/product (FCM) comply with the following European regulations:</p> <ul style="list-style-type: none"> <li>■ (EC) No. 1935/2004, Article 3, Paragraph 1, Articles 5 and 17 on materials and articles intended to come into contact with food.</li> <li>■ (EC) No. 2023/2006 on good manufacturing practice (GMP) for materials and articles intended to come into contact with food.</li> <li>■ (EC) No. 10/2011 on plastic materials and articles intended to come into contact with food.</li> <li>■ All surfaces in contact with the medium are free from materials derived from bovine animals or other livestock (ADI/TSE)</li> </ul>
<b>Marine approval</b>	Information on the Type Approval Certificates currently available (DNVGL, BV, etc.) can be obtained from the sales organization.
<b>Material certification</b>	The material certificate 3.1 (according to standard EN 10204) can be requested separately. The "short form" certificate includes a simplified declaration with no enclosures of documents related to the materials used in the construction of the single sensor and guarantees the traceability of the materials through the identification number of the thermometer. The data related to the origin of the materials can subsequently be requested by the client if necessary.

## Ordering information

1. Click Corporate
2. Select the country
3. Click Products
4. Select the product using the filters and search field
5. Open the product page

The Configuration button to the right of the product image opens the Product Configurator.



**Product Configurator - the tool for individual product configuration**

- Up-to-the-minute configuration data
- Depending on the device: Direct input of measuring point-specific information such as measuring range or operating language
- Automatic verification of exclusion criteria
- Automatic creation of the order code and its breakdown in PDF or Excel output format
-

## Accessories

### Device-specific accessories

#### Welding boss with sealing taper

- Collar welding boss movable with sealing taper, washer and pressure screw G $\frac{1}{2}$ "
- Material of parts in contact with the process: 316L, PEEK
- Max. process pressure 10 bar (145 psi)
- Order number with pressure screw 51004751
- Order number without pressure screw 51004752

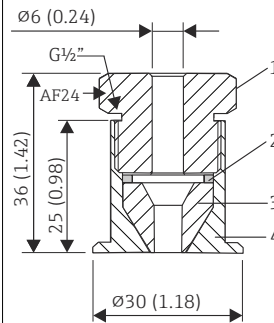

A0020709-EN

11 Dimensions in mm (in)

- 1 Pressure screw, 303/304
- 2 Washer, 303/304
- 3 Sealing taper, PEEK
- 4 Collar welding boss, 316L

#### Collar welding boss

- Collar welding boss movable with sealing taper and washer
- Material of parts in contact with the process: 316L, PEEK
- Max. process pressure 10 bar (145 psi)
- Order number without pressure screw: 51004752

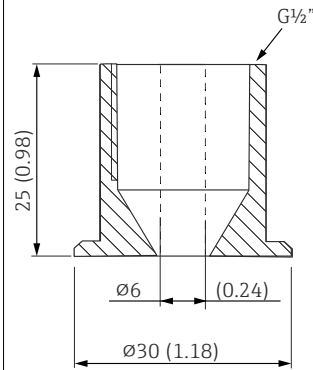

A0020710

12 Dimensions in mm (in)

#### Compression fitting

- Movable clamping ring, various process connections
- Material of compression fitting and parts in contact with the process: 316L
- Order number: TA50-..... (depending on the process connection)

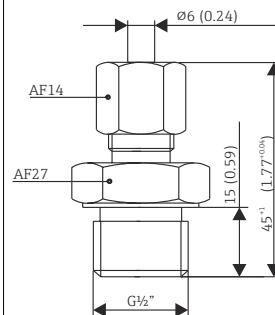

A0020174-EN

13 Dimensions in mm (in)

Version	F in mm (in)		L ~ in mm (in)	C in mm (in)	B in mm (in)	Clamping ring material	Max. process temperature	Max. process pressure
TA50	G½"	SW/AF 27	47 (1.85)	-	15 (0.6)	SS316 <sup>1)</sup>	800 °C (1472 °F)	40 bar at 20 °C (580 psi at 68 °F)
						PTFE <sup>2)</sup>	200 °C (392 °F)	5 bar at 20 °C (72.5 psi at 68 °F)
	G¾"	SW/AF 32	63 (2.48)	-	20 (0.8)	SS316 <sup>1)</sup>	800 °C (1472 °F)	40 bar at 20 °C (580 psi at 68 °F)
						PTFE <sup>2)</sup>	200 °C (392 °F)	5 bar at 20 °C (72.5 psi at 68 °F)
	G1"	SW/AF 41	65 (2.56)	-	25 (0.98)	SS316 <sup>1)</sup>	800 °C (1472 °F)	40 bar at 20 °C (580 psi at 68 °F)
						PTFE <sup>2)</sup>	200 °C (392 °F)	5 bar at 20 °C (72.5 psi at 68 °F)
	NPT½"	SW/AF 22	50 (1.97)	-	20 (0.8)	SS316 <sup>1)</sup>	800 °C (1472 °F)	40 bar at 20 °C (580 psi at 68 °F)
R½"	SW/AF 22	52 (2.05)	-	20 (0.8)	PTFE <sup>2)</sup>	200 °C (392 °F)	5 bar at 20 °C (72.5 psi at 68 °F)	
R¾"	SW/AF 27	52 (2.05)	-	20 (0.8)	PTFE <sup>2)</sup>	200 °C (392 °F)	5 bar at 20 °C (72.5 psi at 68 °F)	

- 1) SS316 clamping ring: can only be used once. Once released the compression fitting cannot be repositioned on the thermowell. Fully adjustable immersion length on initial installation
- 2) PTFE/Elastosil® clamping ring: reusable; once loosened, the compression fitting can be moved up or down on the thermowell. Fully adjustable immersion length

**Communication-specific accessories**

**Coupling; connecting cable**

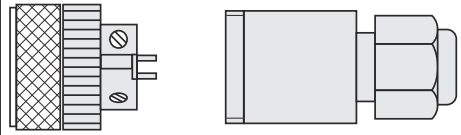
<ul style="list-style-type: none"> <li>▪ Coupling M12x1; straight</li> <li>▪ Connection to M12x1 housing connector</li> <li>▪ Materials: body PA, coupling nut CuZn, nickel-plated</li> <li>▪ Degree of protection (connected): IP 67</li> <li>▪ Order number: 52006263</li> </ul>	 <p style="text-align: right; font-size: small;">A0035843</p>
--	--

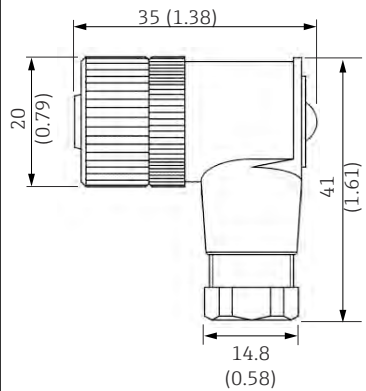
<ul style="list-style-type: none"> <li>▪ M12x1 coupling; elbowed, for termination of connecting cable by user</li> <li>▪ Connection to M12x1 housing connector</li> <li>▪ Materials: body PBT/PA,</li> <li>▪ Coupling nut GD-Zn, nickel-plated</li> <li>▪ Degree of protection (connected): IP 67</li> <li>▪ Order number: 51006327</li> </ul>	 <p style="text-align: right; font-size: small;">A0020722</p>
--	--

14 Dimensions in mm (in)

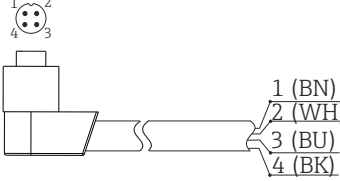

<ul style="list-style-type: none"> <li>▪ PVC cable (terminated), 4 x 0.34 mm<sup>2</sup> with M12x1 coupling, elbowed, screw plug, length 5 m (16.4 ft)</li> <li>▪ Degree of protection: IP67</li> <li>▪ Order number: 51005148</li> </ul> <p>Core colors:</p> <ul style="list-style-type: none"> <li>▪ 1 = BN brown</li> <li>▪ 2 = WH white</li> <li>▪ 3 = BU blue</li> <li>▪ 4 = BK black</li> </ul>	 <p style="text-align: right;">A0020723</p>
--	---

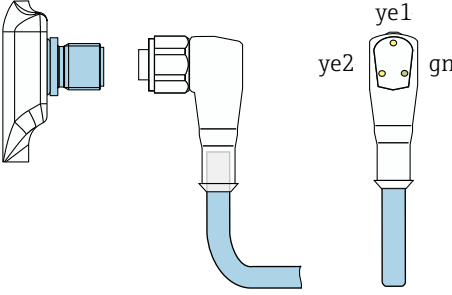
<ul style="list-style-type: none"> <li>▪ PVC cable, 4x 0.34 mm<sup>2</sup> with M12x1 coupling, with LED, elbowed,</li> <li>▪ 316L screw plug, length 5 m (16.4 ft), specially for hygiene applications,</li> <li>▪ Degree of protection (connected): IP69K</li> <li>▪ Order number: 52018763</li> </ul> <p>Display:</p> <ul style="list-style-type: none"> <li>▪ gn: device is operational</li> <li>▪ ye1: switch status 1</li> <li>▪ ye2: switch status 2</li> </ul> <p> Not suitable for 4 to 20 mA analog output!</p>	 <p style="text-align: right;">A0035844</p>
--	---

### Configuration kit

<ul style="list-style-type: none"> <li>▪ Configuration kit for PC-programmable transmitters; Configuration software and interface cable for PC with USB port and 4-pin post connector Order code: TXU10-AA</li> <li>▪</li> </ul>
--

### Technical Information

- Easy Analog RNB130: TI120R/09/en
- Process display unit RIA452: TI113R/09/en
- Universal data manager Ecograph T: TI01079R/09/en
- Data logger Minilog B: TI089R/09/en

### Operating Instructions

Flow switch Flowphant T DTT31, DTT35: BA00235R/09/en

## По вопросам продаж и поддержки обращайтесь:

Алматы (7273)495-231  
Ангарск (3955)60-70-56  
Архангельск (8182)63-90-72  
Астрахань (8512)99-46-04  
Барнаул (3852)73-04-60  
Белгород (4722)40-23-64  
Благовещенск (4162)22-76-07  
Брянск (4832)59-03-52  
Владивосток (423)249-28-31  
Владикавказ (8672)28-90-48  
Владимир (4922)49-43-18  
Волгоград (844)278-03-48  
Вологда (8172)26-41-59  
Воронеж (473)204-51-73  
Екатеринбург (343)384-55-89

Иваново (4932)77-34-06  
Ижевск (3412)26-03-58  
Иркутск (395)279-98-46  
Казань (843)206-01-48  
Калининград (4012)72-03-81  
Калуга (4842)92-23-67  
Кемерово (3842)65-04-62  
Киров (8332)68-02-04  
Коломна (4966)23-41-49  
Кострома (4942)77-07-48  
Краснодар (861)203-40-90  
Красноярск (391)204-63-61  
Курск (4712)77-13-04  
Курган (3522)50-90-47  
Липецк (4742)52-20-81

Магнитогорск (3519)55-03-13  
Москва (495)268-04-70  
Мурманск (8152)59-64-93  
Набережные Челны (8552)20-53-41  
Нижний Новгород (831)429-08-12  
Новокузнецк (3843)20-46-81  
Ноябрьск (3496)41-32-12  
Новосибирск (383)227-86-73  
Омск (3812)21-46-40  
Орел (4862)44-53-42  
Оренбург (3532)37-68-04  
Пенза (8412)22-31-16  
Петрозаводск (8142)55-98-37  
Псков (8112)59-10-37  
Пермь (342)205-81-47

Ростов-на-Дону (863)308-18-15  
Рязань (4912)46-61-64  
Самара (846)206-03-16  
Санкт-Петербург (812)309-46-40  
Саратов (845)249-38-78  
Севастополь (8692)22-31-93  
Саранск (8342)22-96-24  
Симферополь (3652)67-13-56  
Смоленск (4812)29-41-54  
Сочи (862)225-72-31  
Ставрополь (8652)20-65-13  
Сургут (3462)77-98-35  
Сыктывкар (8212)25-95-17  
Тамбов (4752)50-40-97  
Тверь (4822)63-31-35

Тольятти (8482)63-91-07  
Томск (3822)98-41-53  
Тула (4872)33-79-87  
Тюмень (3452)66-21-18  
Ульяновск (8422)24-23-59  
Улан-Удэ (3012)59-97-51  
Уфа (347)229-48-12  
Хабаровск (4212)92-98-04  
Чебоксары (8352)28-53-07  
Челябинск (351)202-03-61  
Череповец (8202)49-02-64  
Чита (3022)38-34-83  
Якутск (4112)23-90-97  
Ярославль (4852)69-52-93

Россия +7(495)268-04-70

Казахстан +7(7172)727-132

Киргизия +996(312)96-26-47

эл.почта: [ehr@nt-rt.ru](mailto:ehr@nt-rt.ru) || сайт: <https://endcounters.nt-rt.ru/>