

Датчики уровня

Liquiphant S FDL70, Liquiphant S FDL71

Техническая информация

По вопросам продаж и поддержки обращайтесь:

Алматы (7273)495-231
Ангарск (3955)60-70-56
Архангельск (8182)63-90-72
Астрахань (8512)99-46-04
Барнаул (3852)73-04-60
Белгород (4722)40-23-64
Благовещенск (4162)22-76-07
Брянск (4832)59-03-52
Владивосток (423)249-28-31
Владикавказ (8672)28-90-48
Владимир (4922)49-43-18
Волгоград (844)278-03-48
Вологда (8172)26-41-59
Воронеж (473)204-51-73
Екатеринбург (343)384-55-89

Иваново (4932)77-34-06
Ижевск (3412)26-03-58
Иркутск (395)279-98-46
Казань (843)206-01-48
Калининград (4012)72-03-81
Калуга (4842)92-23-67
Кемерово (3842)65-04-62
Киров (8332)68-02-04
Коломна (4966)23-41-49
Кострома (4942)77-07-48
Краснодар (861)203-40-90
Красноярск (391)204-63-61
Курск (4712)77-13-04
Курган (3522)50-90-47
Липецк (4742)52-20-81

Магнитогорск (3519)55-03-13
Москва (495)268-04-70
Мурманск (8152)59-64-93
Набережные Челны (8552)20-53-41
Нижний Новгород (831)429-08-12
Новокузнецк (3843)20-46-81
Ноябрьск (3496)41-32-12
Новосибирск (383)227-86-73
Омск (3812)21-46-40
Орел (4862)44-53-42
Оренбург (3532)37-68-04
Пенза (8412)22-31-16
Петрозаводск (8142)55-98-37
Псков (8112)59-10-37
Пермь (342)205-81-47

Ростов-на-Дону (863)308-18-15
Рязань (4912)46-61-64
Самара (846)206-03-16
Санкт-Петербург (812)309-46-40
Саратов (845)249-38-78
Севастополь (8692)22-31-93
Саранск (8342)22-96-24
Симферополь (3652)67-13-56
Смоленск (4812)29-41-54
Сочи (862)225-72-31
Ставрополь (8652)20-65-13
Сургут (3462)77-98-35
Сыктывкар (8212)25-95-17
Тамбов (4752)50-40-97
Тверь (4822)63-31-35

Тольятти (8482)63-91-07
Томск (3822)98-41-53
Тула (4872)33-79-87
Тюмень (3452)66-21-18
Ульяновск (8422)24-23-59
Улан-Удэ (3012)59-97-51
Уфа (347)229-48-12
Хабаровск (4212)92-98-04
Чебоксары (8352)28-53-07
Челябинск (351)202-03-61
Череповец (8202)49-02-64
Чита (3022)38-34-83
Якутск (4112)23-90-97
Ярославль (4852)69-52-93

Россия +7(495)268-04-70

Казахстан +7(7172)727-132

Киргизия +996(312)96-26-47

эл.почта: ehr@nt-rt.ru || сайт: <https://endcounters.nt-rt.ru/>

Technical Information

Liquiphant S FTL70, FTL71

Vibronic



High-temperature point level switch for all types of liquids

Application

The Liquiphant S is a point level switch for use in all types of liquids

- for process temperatures between $-60\text{ }^{\circ}\text{C}$ and $280\text{ }^{\circ}\text{C}$ ($-76\text{ }^{\circ}\text{F}$ to $540\text{ }^{\circ}\text{F}$) ($300\text{ }^{\circ}\text{C}$ ($572\text{ }^{\circ}\text{C}$) for max. 50 cumulative hours; without thermal shock restriction)
- for pressures up to 100 bar (1450 psi)
- for viscosities up to $10,000\text{ mPa}\cdot\text{s}$ (cSt)
- for density $\geq 0.5\text{ g/cm}^3$ (SGU) or $\geq 0.7\text{ g/cm}^3$ (SGU), other configurations on request
- Foam detection on request

The function is not affected by flow, turbulence, bubbles, foam, vibration, solids content or buildup, making the Liquiphant an ideal substitute for float switches.

FTL70: Compact design, for pipes also

FTL71: Extension pipe up to 3 m (9.8 ft) and up to 6 m (20 ft) on request

For use in very aggressive liquids, the fork and process connection are available in the highly corrosion-resistant material AlloyC22 (2.4602).

EEx ia, EEx de and EEx d protection enable it to be used in hazardous areas.

Your benefits

- Use in safety systems requiring functional safety to SIL2 in accordance with IEC 61508/IEC 61511-1
- Welded, gas-tight feed-through ensures maximum safety, even in the event of damage to sensor
- With process connections from $\frac{3}{4}$ " and small fork dimensions, it is also suitable where space is tight.
- A wide range of process connections allows for universal application.
- The right connection for every process control system: e.g. NAMUR, relay, DC-PMP,
- PROFIBUS PA interface
- No adjustment: quick, low-cost startup
- No mechanical moving parts: maintenance-free

Table of contents

Application	4	Electronic insert FEL57 (PFM)	13
Point level detection	4	Power supply	13
Function and system design	4	Electrical connection	13
Measuring principle	4	Output signal	14
Modularity	4	Signal on alarm	14
Electronic versions	5	Connectable load	14
Galvanic isolation	5	Electronic insert FEL50A (PROFIBUS PA)	15
Design	5	Power supply	15
Input	5	Electrical connection	15
Measured variable	5	Output signal	16
Measuring range (detection range)	5	Signal on alarm	16
Process density	5	Connection and function	16
Electronic insert FEL51 (AC 2-wire)	6	Connecting cables	16
Power supply	6	Safety mode	16
Electrical connection	6	Switching time	16
Output signal	6	Switch-on behavior	16
Signal on alarm	6	Accuracy	16
Connectable load	6	Reference operating conditions	16
Electronic insert FEL52 (DC PNP)	8	Maximum measured error	17
Power supply	8	Repeatability	17
Electrical connection	8	Hysteresis	17
Output signal	8	Influence of process temperature	17
Signal on alarm	8	Influence of process density	17
Connectable load	8	Influence of process pressure	17
Electronic insert FEL54 (AC/DC with relay output)	9	Switching delay	17
Power supply	9	Operating conditions	17
Electrical connection	9	Installation	17
Output signal	9	Examples of mounting	17
Signal on alarm	9	Orientation	19
Connectable load	9	Environment	20
Electronic insert FEL55 (8/16 mA)	10	Ambient temperature range	20
Power supply	10	Ambient temperature limits	20
Electrical connection	10	Storage temperature	20
Output signal	10	Installation height as per IEC61010-1 Ed.3	20
Signal on alarm	10	Climate class	20
Connectable load	10	Degree of protection	20
Electronic insert FEL56 (NAMUR L-H edge)	11	Vibration resistance	20
Power supply	11	Electromagnetic compatibility	21
Electrical connection	11	Process conditions	21
Output signal	11	Process temperature	21
Signal on alarm	11	Thermal shock	21
Connectable load	11	Process pressure pe	21
Electronic insert FEL58 (NAMUR H-L edge)	12	Test pressure	21
Power supply	12	State of aggregation	21
Electrical connection	12	Density	21
Output signal	12	Viscosity	21
Signal on alarm	12	Solids content	21
Connectable load	12	Lateral loading	21
		Medium conditions	21

Mechanical construction	22
Design	22
Dimensions	23
Weights	26
Materials	26
Process connections	27
Operability	27
Electronic inserts	27
Operating concept	28
Certificates and approvals	28
CE mark	28
RoHS	28
RCM-tick mark	28
Other certificates	28
EAC conformity	28
CRN approval	28
Process seal according to ANSI/ISA 12.27.01	29
Pressure Equipment Directive 2014/68/EU (PED)	29
Use in hazardous zones	29
ASME B 31.3	29
Combinations of housing and electronic inserts	30
Ordering information	31
Ordering information Liquiphant S FTL70, FTL71	31
Accessories	34
Lap joint flange	34
Lap joint flanges	34
Weather protection cover	35
Sliding sleeves for unpressurized operation	35
High pressure sliding sleeves	36
Cover with sight glass	37
Cover with sight glass	37
Documentation	37
Operating Instructions	37
Technical Information	38
Functional safety (SIL)	38
Safety Instructions (ATEX)	39
Safety Instructions (NEPSI)	39
Control Drawings	39

Application

Point level detection

Maximum or minimum detection in tanks or pipes with all types of cold to very hot liquids. The devices are also suitable for use in hazardous areas and for applications involving high pressure.

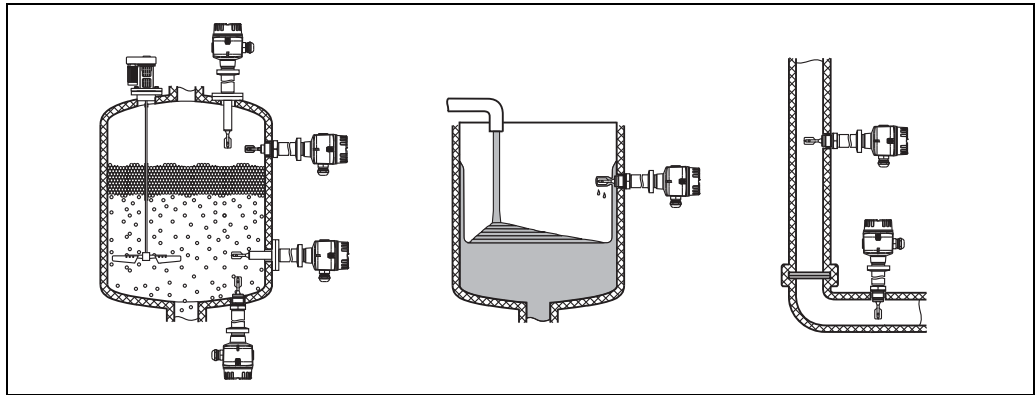

L00-FTL7xxxx-11-05-xx-xx-001

Function and system design

Measuring principle

The sensor's fork vibrates at its intrinsic frequency. This frequency is reduced when covered with liquid. This change in frequency causes the point level switch to switch.

Modularity

Point level switch

Liquiphant S FTL7x with electronic inserts
FEL51, FEL52, FEL54

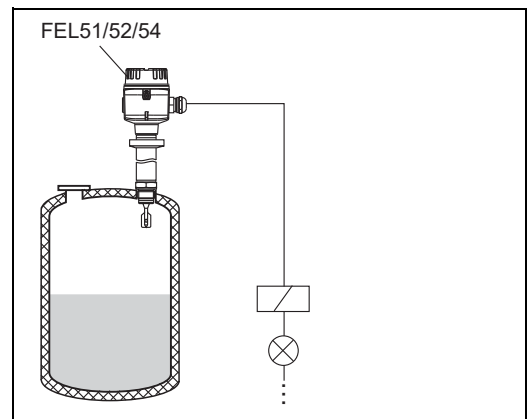

L00-FTL7xxxx-15-05-xx-xx-000

Point level switch

Liquiphant S FTL7x with electronic inserts
FEL55, FEL56, FEL57, FEL58, FEL50A
for connecting to a separate switching unit,
an isolating amplifier or for connecting
to a PROFIBUS PA segment coupler

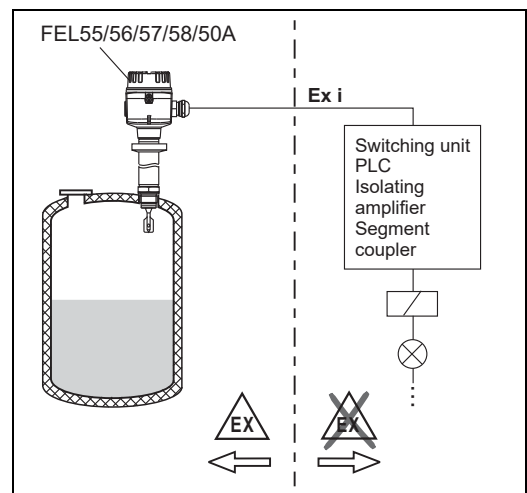

L00-FTL7xxxx-15-05-xx-en-000

Electronic versions	<p>FEL51: Two-wire AC version; Switches the load directly into the power supply circuit via an electronic switch.</p> <p>FEL52: Three-wire DC version; Switches the load via the transistor (PNP) and separate connection e.g. in conjunction with programmable logic controllers (PLCs), DI modules as per EN 61131-2.</p> <p>FEL54: Universal current version with relay output; Switches the loads via 2 floating change-over contacts.</p> <p>FEL55: Signal transmission 16/8 mA on two-wire cabling e.g. in conjunction with programmable logic controllers (PLCs), AI modules 4 to 20 mA as per EN 61131-2.</p> <p>FEL56: For separate switching unit; signal transmission L-H edge 0.6 to 1.0 / 2.2 to 2.8 mA to EN 50227 (NAMUR) on two-wire cabling.</p> <p>FEL58: For separate switching unit; signal transmission H-L edge 2.2 to 3.5 / 0.6 to 1.0 mA to EN 50227 (NAMUR) on two-wire cabling. Checking of connecting cabling and other devices by pressing a key on the electronic insert.</p> <p>FEL57: For separate switching unit; PFM signal transmission; Current pulses superposed on the power supply along the two-wire cabling. Proof test from the switching unit without changing levels.</p> <p>FEL50A: For connecting to PROFIBUS PA; Cyclic and acyclic data exchange acc. to PROFIBUS-PA Profile 3.0 Discrete Input</p>
----------------------------	--

Galvanic isolation	<p>FEL51, FEL52, FEL50A: between sensor and power supply</p> <p>FEL54: between sensor and power supply and load</p> <p>FEL55, FEL56, FEL57, FEL58, FEL50D: see connected switching unit</p>
---------------------------	---

Design	<p>FTL70: Compact</p> <p>FTL71: With extension pipe</p>
---------------	---

Input

Measured variable	Level (limit value)
Measuring range (detection range)	<p>FTL70: dependent on mounting point</p> <p>FTL71: dependent on mounting point and the extension pipe ordered. Standard extension pipe up to 3 m (9.8 ft) and up to 6 m (20 ft) on request.</p>
Process density	Setting on the electronic insert > 0.5 g/cm ³ (SGU) or > 0.7 g/cm ³ (SGU) (others on request)

Electronic insert FEL51 (AC 2-wire)

Power supply

Supply voltage: AC 19 to 253 V
 Power consumption: < 0.83 W
 Residual current consumption: < 3.8 mA
 Short-circuit protection
 Overvoltage protection FEL51: overvoltage category III

Electrical connection

Two-wire AC connection

Switches the load directly into the power supply circuit via an electronic switch.

Always connect in series with a load!

Check the following:

- The residual current in blocked state (up to 3.8 mA)
- That for low voltage
 - the voltage drop across the load is such that the minimum terminal voltage at the electronic insert (19 V) when blocked is not undershot.
 - the voltage drop across the electronics when switched through is observed (up to 12 V)
- That a relay cannot de-energize with holding power below 3.8 mA.
 If this is the case, a resistor should be connected parallel to the relay. An RC module is available under the part number: 71107226
- When selecting the relay, pay attention to the holding power / rated power (see "Connectable load")

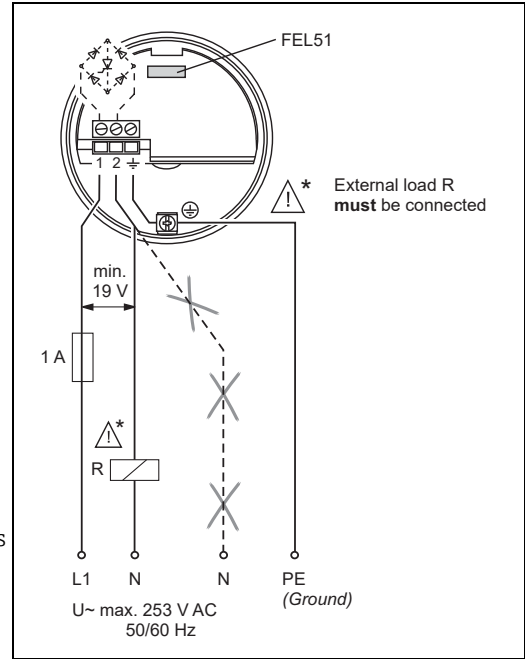

L00-FTL5xxxx-04-05-xx-en-007

Output signal

I_L = load current (switched through)

< 3.8 mA = residual current (blocked)

= lit

= unlit

L00-FTL2xxxx-07-05-xx-xx-000

Safety mode	Level	Output signal	LEDs	
			green	red
MAX		1 I_L 2		
		1 < 3.8 mA 2		
MIN		1 I_L 2		
		1 < 3.8 mA 2		

L00-FTL5xxxx-04-05-xx-xx-003

Signal on alarm

Output signal on power failure or in the event of damaged sensor: < 3.8 mA

Connectable load

- Voltage drop via FEL51 \leq 12 V
- Residual current if electrical switch is blocked: \leq 3.8 mA
- Load switched directly into the power supply circuit via the thyristor.
 Transient (40 ms) \leq 1.5 A, \leq 375 VA at 253 V or \leq 36 VA at 24 V (not short-circuit-proof)

The load is switched via an electronic switch directly in the power circuit.

Always connect in series with a load!

Not suitable for connection to low-voltage PLC inputs!

Selection guide for relays

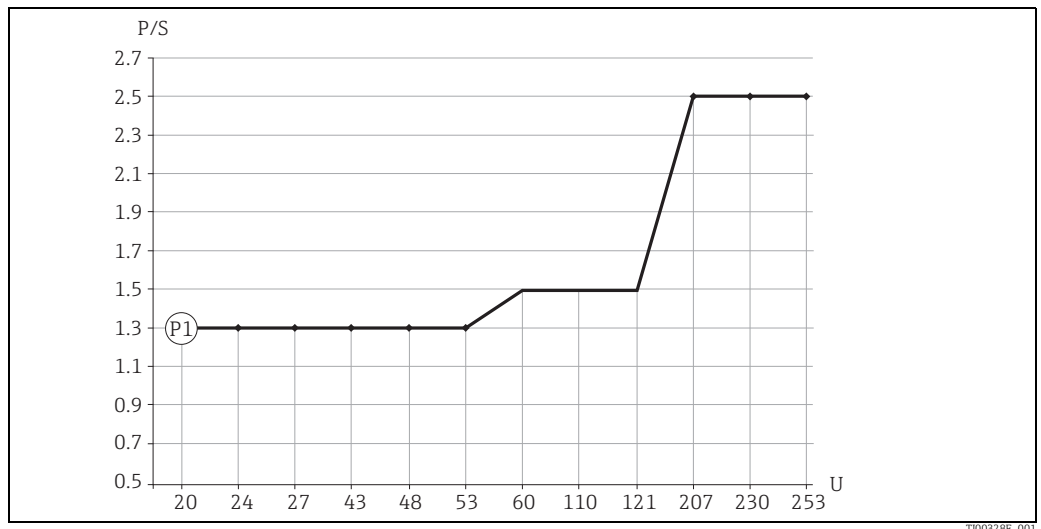

Minimum nominal power of load
P/S nominal power in [W] / [VA]
U operating voltage in [V]

Position	Operating voltage	Nominal power	
		min.	max.
P1	24 V	> 1.3 VA	< 8.4 VA
AC operation	110 V	> 1.5 VA	< 38.5 VA
	230 V	> 2.5 VA	< 80.5 VA

Relays with less nominal power can be operated via an RC module connected in parallel (optional).

Electronic insert FEL52 (DC PNP)

Power supply

Supply voltage: DC 10 to 55 V
 Ripple: ≤ 1.7 V, 0 to 400 Hz
 Current consumption: ≤ 15 mA
 Power consumption: ≤ 0.83 W
 Reverse polarity protection
 Overvoltage protection FEL52: overvoltage category III

Electrical connection

Three-wire DC connection

Switches the load via the transistor (PNP) and separate connection.
 Preferably used with programmable logic controllers (PLC),
 DI modules as per EN 61131-2.
 Positive signal at switching output of the electronics (PNP); Output blocked on reaching point level.

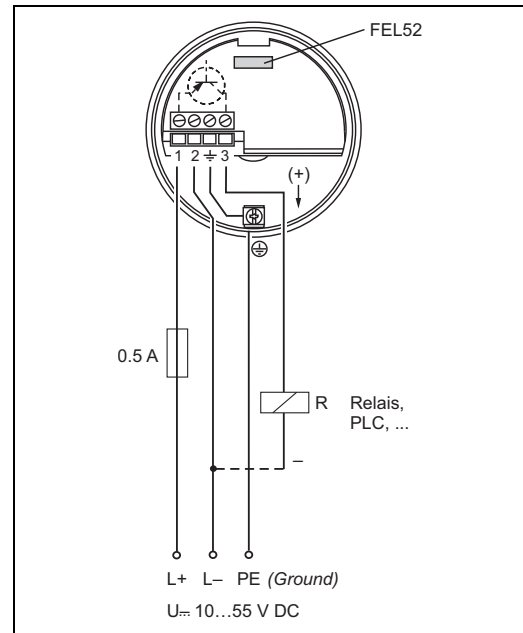

L00-FTL5xxxx-04-05-xx-xx-030

Output signal

I_L = load current (switched through)

$< 100 \mu A$ = residual current (blocked)

= lit

= unlit

L00-FTL2xxxx-07-05-xx-xx-000

Safety mode	Level	Output signal	LEDs	
			green	red
MAX		$L+ \xrightarrow{I_L} +$ 1 → 3		
		$< 100 \mu A$ 1 - - - - -> 3		
MIN		$L+ \xrightarrow{I_L} +$ 1 → 3		
		$< 100 \mu A$ 1 - - - - -> 3		

L00-FTL5xxxx-04-05-xx-xx-004

Signal on alarm

Output signal on power failure or in the event of damaged sensor: $< 100 \mu A$

Connectable load

- Load switched via transistor and separate PNP connection, \leq DC 55 V
- Load current ≤ 350 mA (pulsed overload and short-circuit protection)
- Residual current $< 100 \mu A$ (with transistor blocked)
- Capacitance load $\leq 0.5 \mu F$ at 55 V, $1.0 \mu F$ at 24 V
- Residual voltage < 3 V (with transistor switched through);

Electronic insert FEL54 (AC/DC with relay output)

Power supply

Supply voltage: AC 19 to 253 V, 50/60 Hz or DC 19 to 55 V
 Power consumption: ≤ 1.3 W
 Reverse polarity protection
 Overvoltage protection FEL54: overvoltage category III

Electrical connection

Universal current connection with relay output

Power supply:
 Please note the different voltage ranges for AC and DC.

Output:
 When connecting an instrument with high inductance, provide a spark arrester to protect the relay contact.
 A fine-wire fuse (depending on the load connected) protects the relay contact on short-circuiting.
 Both relay contacts switch simultaneously.

* When jumpered, the relay output works with NPN logic.

** See "Connectable load"

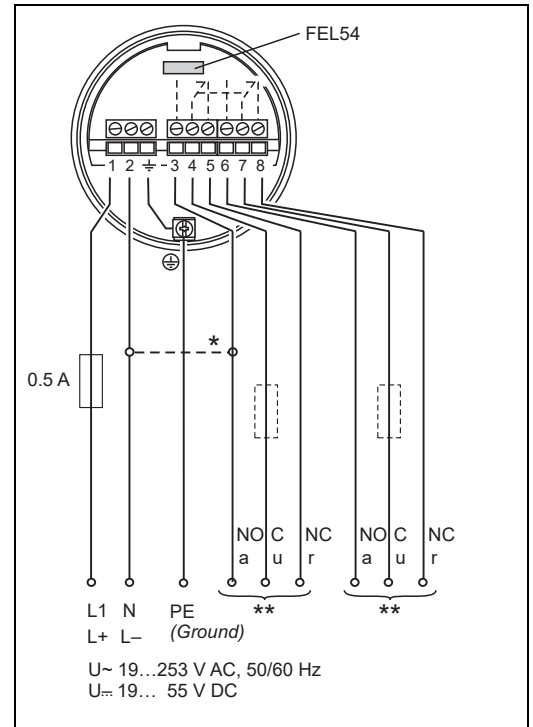

Output signal

= relay energized
 = relay de-energized
 = lit
 = unlit

L00-FTL2xxxx-07-05-xx-xx-001

Safety mode	Level	Output signal		LEDs	
		3 4 5	6 7 8	green	red
MAX					
MIN					

L00-FTL5xxxx-04-05-xx-xx-003

Signal on alarm

Output signal on power failure or in the event of damaged sensor: relay de-energized

Connectable load

- Loads switched via 2 floating change-over contacts (DPDT).
- $I_{\sim} \leq 6 \text{ A}$ (Ex de 4 A), $U_{\sim} \leq \text{AC } 253 \text{ V}$; $P_{\sim} \leq 1500 \text{ VA}$, $\cos \varphi = 1$, $P_{\sim} \leq 750 \text{ VA}$, $\cos \varphi > 0.7$
- $I_{\text{DC}} \leq 6 \text{ A}$ (Ex de 4 A) to DC 30 V, $I_{\text{DC}} \leq 0.2 \text{ A}$ to 125 V
- When connecting a low-voltage circuit with double insulation according to IEC 1010, the following applies: the sum of the voltages of the relay output and power supply is ≤ 300 V
- The electronic insert FEL52 DC-PNP is preferred for low DC load currents (e.g. when connecting to a PLC)
- Relay contact material: silver/nickel AgNi 90/10

Electronic insert FEL55 (8/16 mA)

Power supply

Supply voltage: DC 11 to 36 V
 Power consumption: < 600 mW
 Reverse polarity protection
 Overvoltage protection FEL55: overvoltage category III

Electrical connection

Two-wire connection for separate switching unit

For separate switching unit.
 Signal transmission 16/8 mA on two-wire cabling.
 For connection to programmable logic controllers (PLC) for example, AI modules 4 to 20 mA to EN 61131-2.
 Output signal jump from high to low current on point level.

Fuse required for non-Ex applications!
 Only use power units with safe galvanic isolation (e.g. SELV).

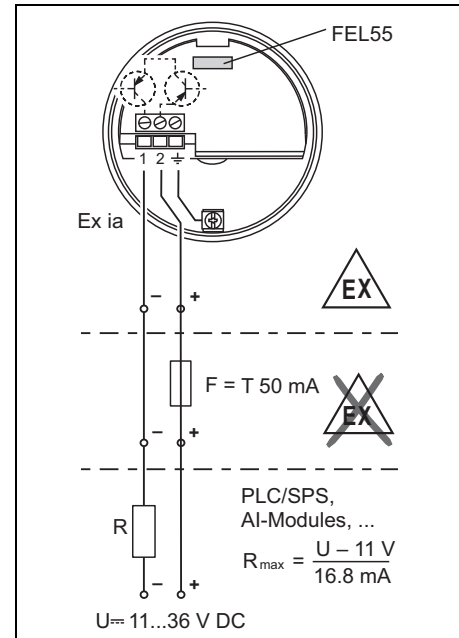

L00-FTL5xxxx-04-05-xx-xx-000

Output signal

$$\sim 16 \text{ mA} = 16 \text{ mA} \pm 5 \%$$

$$\sim 8 \text{ mA} = 8 \text{ mA} \pm 6 \%$$

= lit

= unlit

L00-FTL2xxxx-07-05-xx-xx-000

Safety mode	Level	Output signal	LEDs	
			green	red
MAX		+ ~16 mA → 1		
		+ ~8 mA → 1		
MIN		+ ~16 mA → 1		
		+ ~8 mA → 1		

L00-FTL5xxxx-04-05-xx-xx-000

Signal on alarm

Output signal on power failure or in the event of damaged sensor: < 3.6 mA

Connectable load

- $R = (U - 11 \text{ V}) : 16.8 \text{ mA}$
- $U = \text{connection voltage: DC 11 to 36 V (in wet environments DC 11 to 35 V)}$

Example: PLC with 250 Ω with 2-wire version

$$250 \Omega = (U - 11 \text{ V}) / 16.8 \text{ mA}$$

$$4.2 [\Omega / \text{A}] = U - 11 \text{ V}$$

$$U = 15.2 \text{ V}$$

Electronic insert FEL56 (NAMUR L-H edge)

Power supply

Supply voltage: DC 8.2 V \pm 20 %
 Power consumption: < 6 mW at I < 1 mA; < 38 mW at I = 2.8 mA
 Connection data interface: IEC 60947-5-6

Electrical connection

Two-wire connection for separate switching unit

For connecting to isolating amplifiers according to Output signal jump from low to high current on point level.

(L-H edge)

Connecting to multiplexer:
 Set clock time to min. 2 s.

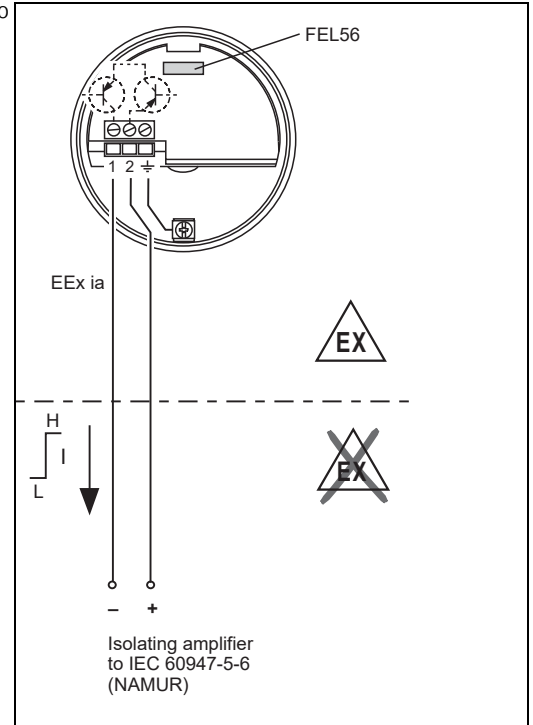

L00-FTL5xxxx-04-05-xx-en-004

Output signal

☀ = lit
 ⚡ = flashes
 ● = unlit

L00-FTL5xxxx-07-05-xx-xx-002

Safety mode	Level	Output signal	LEDs	
			green	red
MAX		+ 0.6 ... 1.0 mA 2 → 1	⚡	●
		+ 2.2 ... 2.8 mA 2 → 1	☀	☀
MIN		+ 0.6 ... 1.0 mA 2 → 1	⚡	●
		+ 2.2 ... 2.8 mA 2 → 1	⚡	☀

L00-FTL5xxxx-04-05-xx-xx-003

Signal on alarm

Output signal in the event of damaged sensor: > 2.2 mA

Connectable load

- See Technical Data of the isolating amplifier connected according to IEC 60947-5-6 (NAMUR)

Electronic insert FEL58 (NAMUR H-L edge)

Power supply

Supply voltage: DC 8.2 V \pm 20 %
 Power consumption: < 6 mW at I < 1 mA; < 38 mW at I = 3.5 mA
 Connection data interface: IEC 60947-5-6

Electrical connection

Two-wire connection for separate switching unit

For connecting to isolating amplifiers as per NAMUR (IEC 60947-5-6), e.g. FTL325N, FTL375N from Output signal jump from high to low current on point level.

(H-L edge)

Additional function:
 Test key on the electronic insert.
 Pressing the key breaks the connection to the isolating amplifier.





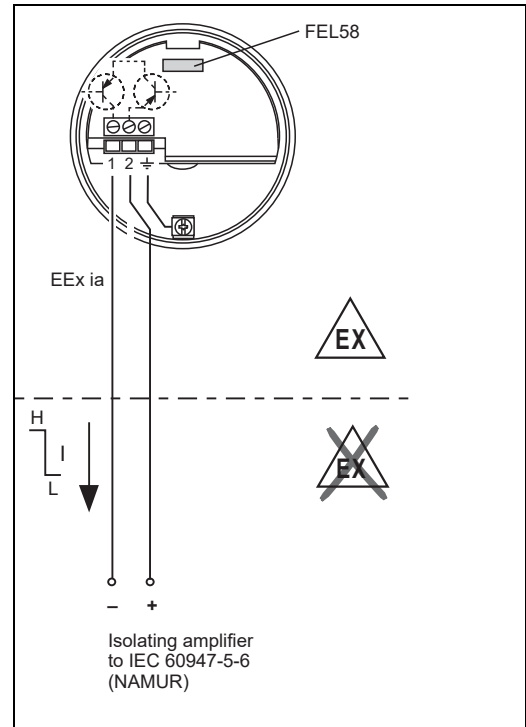



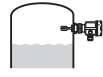

 **Note!**
 In Ex-d applications, the additional function can only be used if the housing is not exposed to an explosive atmosphere.

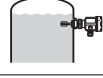

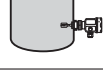
Connecting to multiplexer:
 Set clock time to min. 2 s.



L00-FTL5xxxx-04-05-xx-en-002

Output signal

Safety mode	Level	Output signal	LEDs green yellow
MAX		+ 2.2 ... 3.5 mA → 1	 
		+ 0.6 ... 1.0 mA → 1	 
MIN		+ 2.2 ... 3.5 mA → 1	 
		+ 0.6 ... 1.0 mA → 1	 

 = lit
 = flashes
 = unlit

L00-FTL5xxxx-07-05-xx-xx-002

L00-FTL5xxxx-04-05-xx-xx-007

Signal on alarm

Output signal in the event of damaged sensor: < 1.0 mA

Connectable load

- See Technical Data of the isolating amplifier connected according to IEC 60947-5-6 (NAMUR)
- Connection also to isolating amplifiers which have special safety circuits (I > 3.0 mA)

Electronic insert FEL57 (PFM)

Power supply

Supply voltage: DC 9.5 to 12.5 V
 Current consumption: 10 to 13 mA
 Power consumption: < 150 mW
 Reverse polarity protection

Electrical connection

Two-wire connection for separate switching unit

For connecting to switching units Nivotester FTL320, FTL325P, FTL370, FTL372, FTL375P (also with proof test).

Output signal jump of the PFM signal from high to low frequency when sensor is covered. Switching between minimum/maximum safety in the Nivotester.

Additional function "proof test":

After interruption of the power supply, a test cycle is activated which checks the sensor and electronics without any change in level.

Approved for overfill protection acc. to WHG (German Water Resources Act).

The following can be switched at the electronic insert:

– **Standard (STD):**

Corrosion of the fork unlikely; simulation approx. 8 s
 tuning fork exposed – covered – exposed.
 For proof testing, the Nivotester tests the sensor's level notification function.

– **Extended (EXT):**

Corrosion of the fork possible; simulation approx. 41 s: tuning fork exposed – covered – corroded – exposed.
 For proof testing, the Nivotester tests the sensor's level notification function and fault notification (alarm) function.

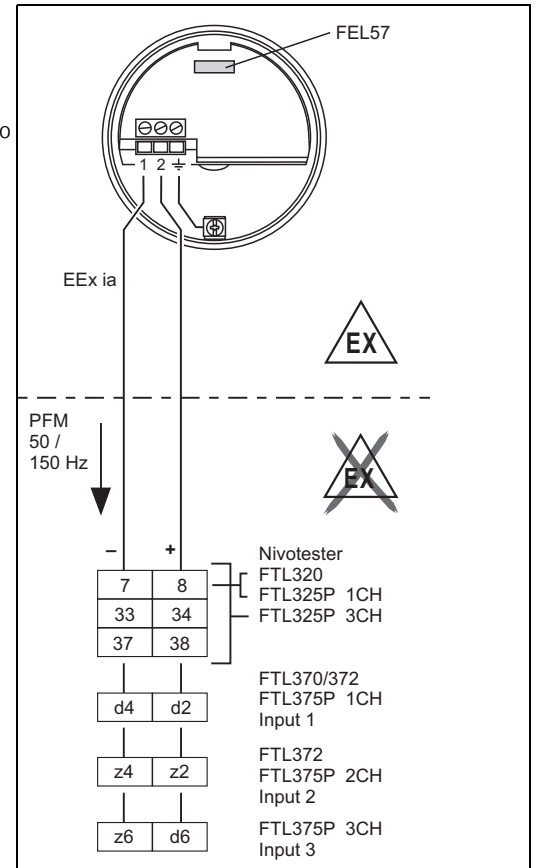

The check is activated and monitored at the switching unit.

The twin-core connecting cable (instrument cable) with a cable resistance of $\leq 25\Omega$ per core is connected to the screw terminals (conductor cross-sections 0.5 to 2.5 mm / 0.02 to 0.1 in) in the connection compartment. Protective circuits against reverse polarity, HF influences and overvoltage peaks are installed.

Maximum cable length up to 1000 m (3281 ft).

A shielded connecting cable is recommended in the event of strong electromagnetic interference. Here the shielding must be connected to the sensor and the power supply.

Switching behavior of the connected device:

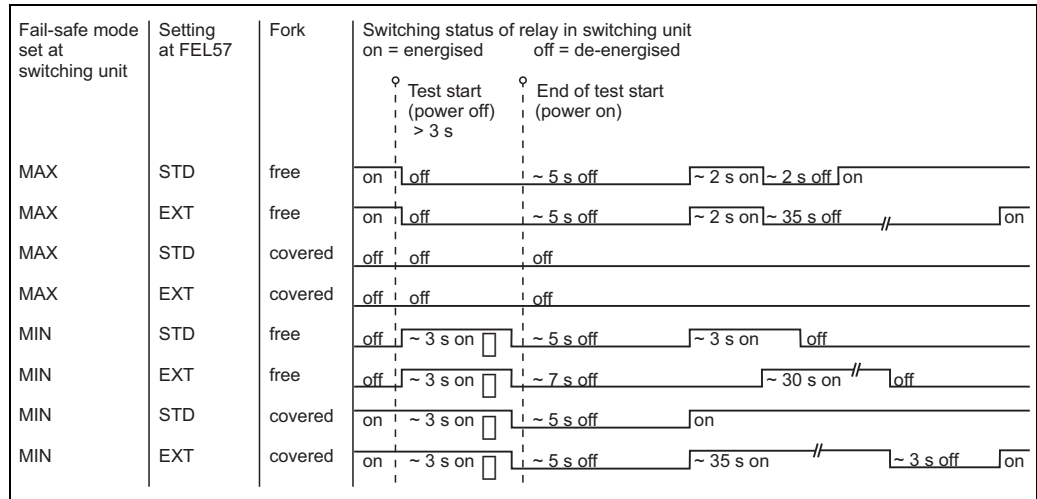

* De-energised on power supply failure

Please note this switching response and function of the plant especially when replacing a Liquiphant incorporating electronic insert EL17Z or FEL37 with a Liquiphant M incorporating electronic insert FEL57.

Output signal

☀ = lit
● = unlit

L00-FTL2xxxx-07-05-xx-xx-000

Safety mode	Level	Output signal (PFM)	LEDs green	LEDs yellow
		150 Hz	☀	☀
		50 Hz	☀	●

L00-FTL5xxxx-04-05-xx-xx-000

Signal on alarm

Output signal on power failure or in the event of damaged sensor: 0 Hz

Connectable load

- Floating relay contacts in the connected switching unit Nivotester FTL325P, FTL375P
- For contact load, see the Technical Data of the switching unit.

Electronic insert FEL50A (PROFIBUS PA)

Power supply

Bus voltage: DC 9 to 32 V

Bus current:

- 12.5 mA +/- 1.0 mA (software version: 01.03.00, hardware version: 02.00)
- 10.5 mA +/- 1.0 mA (software version: 01.03.00, hardware version: 01.00)

Electrical connection

Two-wire connection for power supply and data transfer

For connecting to PROFIBUS PA

Additional functions:

- Digital communication enables the representation, reading and editing of the following parameters:
Fork frequency, switch-on frequency, switch-off frequency, switch-on time and switch-off time, status, measured value, density change
- Matrix locking possible
- Switch to WHG mode possible (WHG approval)
- For a detailed description, see BA00198F

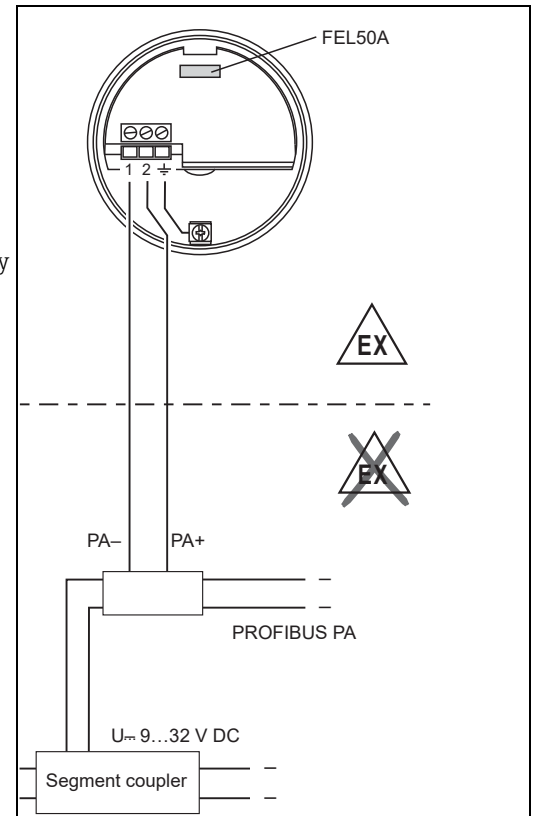

L00-FTL5xxxx-04-05-xx-en-005

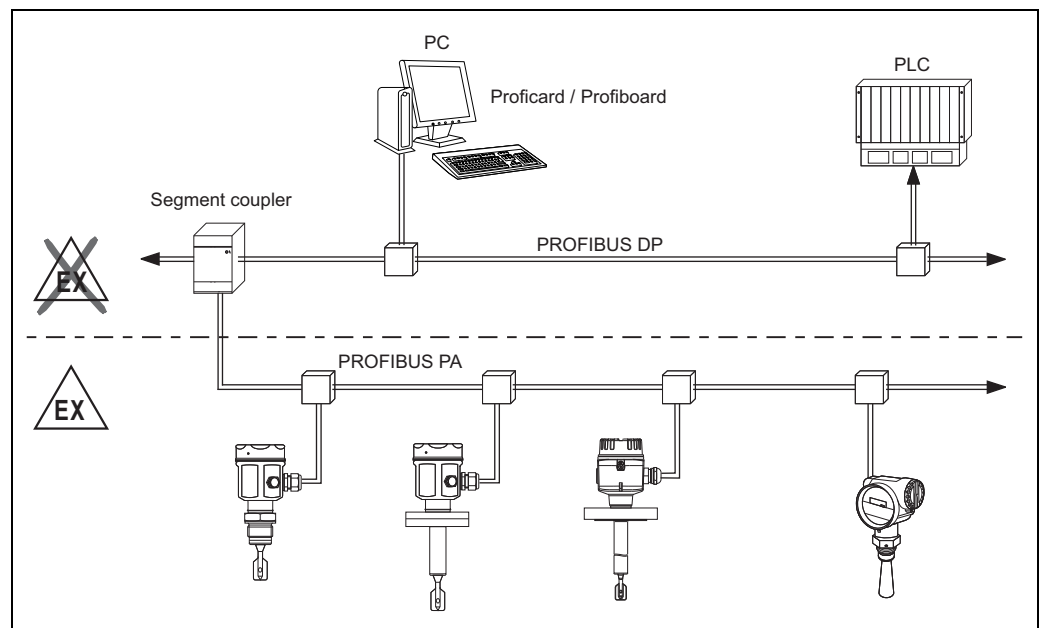

L00-FTL5xxxx-04-05-xx-xx-100

Output signal

☀ = lit
● = unlit

L00-FTL2xxxx-07-05-
xx-xx-000

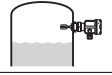
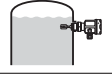
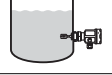
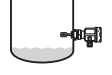
Setting	Level	LEDs		FEL50A
		green	yellow	
not inverted		☀	●	OUT_D = 0 PA bus signal
		☀	☀	OUT_D = 1 PA bus signal
inverted		☀	☀	OUT_D = 0 PA bus signal
		☀	●	OUT_D = 1 PA bus signal

L00-FTL5xxxx-04-05-xx-xx-009

Signal on alarm

- Failure information can be opened using the following interfaces:
Yellow LED flashing, status code, diagnostic code; see BA00198F

Connection and function

Connecting cables

- Electronic inserts: cross-section $\leq 2.5 \text{ mm}^2$ (14 AWG); strand in ferrule as per DIN 46228
- Protective ground in housing: cross-section $\leq 2.5 \text{ mm}^2$ (14 AWG)
- External equipotential bonding connection on housing: cross-section $\leq 4 \text{ mm}^2$ (12 AWG)

Safety mode

Minimum/maximum residual current safety selectable on electronic insert
(with FEL57 on Nivotester only)

MAX = maximum safety:

The output switches to the power fail response when the fork is covered
For use with overfill protection for example

MIN = minimum safety:

The output switches to the power fail response when the fork is exposed
For use with dry running protection for example

Switching time

When fork is covered: approx. 0.5 s
When fork is exposed: approx. 1.0 s
Additionally configurable for PROFIBUS PA:
0.5 to 60 s

Other switching times available on request.

Switch-on behavior

When switching on the power supply, the output assumes the alarm signal.
After $\leq 3 \text{ s}$ it assumes the correct switching mode (exception: FEL57)

Accuracy

Reference operating conditions

Ambient temperature: 23 °C (73 °F)
Medium temperature: 23 °C (73 °F)
Medium density (water): 1 g/cm³ (SGU)
Medium viscosity: 1 mm²/s (cSt)
Medium pressure p_e : 0 bar (0 psi)
Sensor mounting: vertical from above
Density switch: to $> 0.7 \text{ g/cm}^3$ (SGU)

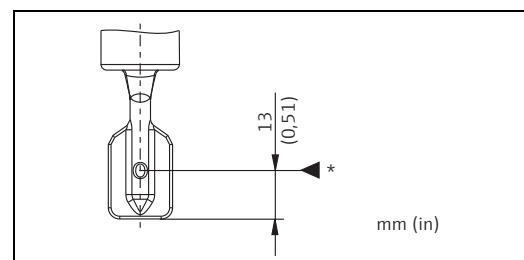

L00-FTL5xxxx-06-05-xx-xx-031

* Switch point under reference operating conditions

Maximum measured error	Under reference operating conditions: max. +/-1 mm (0.04 in)
Repeatability	0.1 mm (0.004 in)
Hysteresis	approx. 2 mm (0.08 in)
Influence of process temperature	max. +1.4 to -5.5 mm (-60 to +280 °C) max. +0.06 to -0.22 in
Influence of process density	max. +4.8 to -3.5 mm ((0.5 to 1.5 g/cm ³ (SGU)) max. +0.19 to -0.14 in
Influence of process pressure	max. 0 to -3.9 mm (-1 to 100 bar (-14.5 to 1450 psi)) max. 0 to -0.15 in
Switching delay	<ul style="list-style-type: none"> ■ When fork is covered: 0.5 s ■ When fork is exposed: 1.0 s ■ Available on request: 0.2 s; 1.5 s or 5 s (when the tuning fork is covered or exposed)

Operating conditions

Installation

Installation instructions

Switch points \pm on the sensor depend on the mounting position, with reference to water, Density 1 g/cm³ (SGU), 23 °C (73 °F), p_e 0 bar (0 psi).

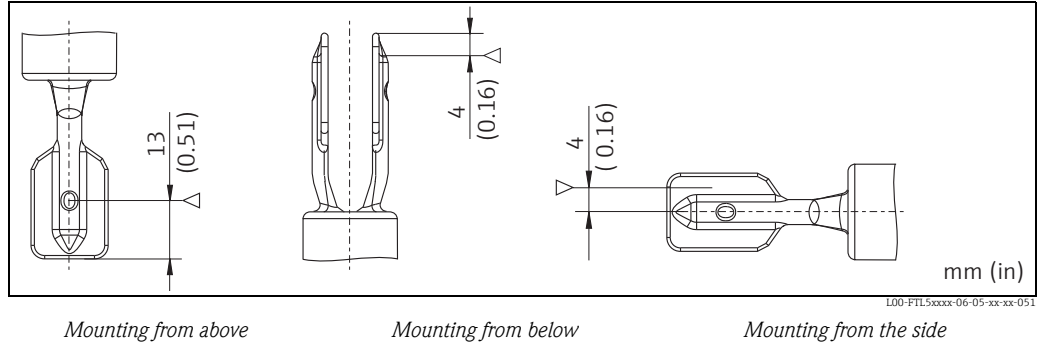

Examples of mounting

Depending on the viscosity ν of the liquid and the tendency to form buildup

Optimum mounting, without problem even with high viscosity:

Position the fork so that the narrow edge of the tines is vertical to ensure that the liquid can run off easily.

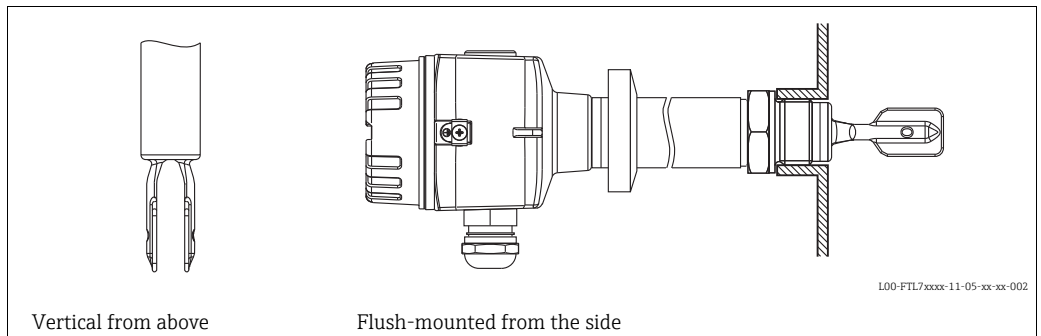

With buildup on the tank walls:

* Ensure that there is sufficient distance between the buildup expected on the tank wall and the fork.

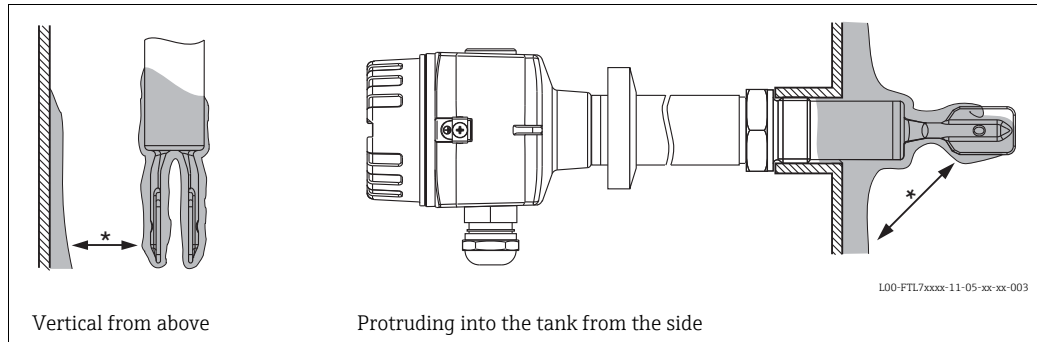

Mounting positions in the case of low viscosity (up to 2000 mm²/s (cSt)):

* Deburr the nozzle surfaces

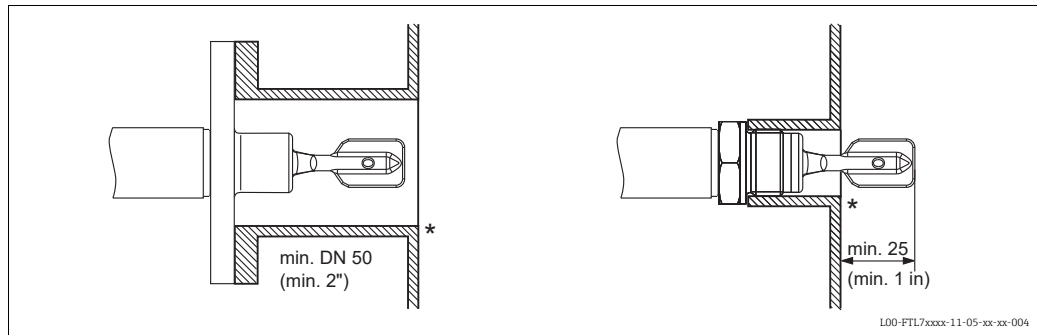

Installation in pipes from 2":

Flow velocities up to 5 m/s (16.4 ft/s) for viscosity of 1 mm²/s (cSt) and density 1 g/cm³ (SGU).
(Check the function for other medium conditions.)

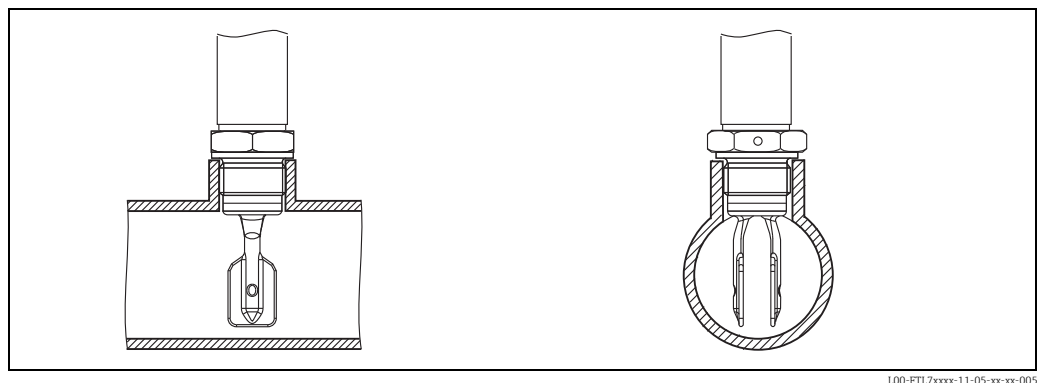

Dynamic load

Support the Liquiphant S FTL71 in the event of a severe dynamic load.

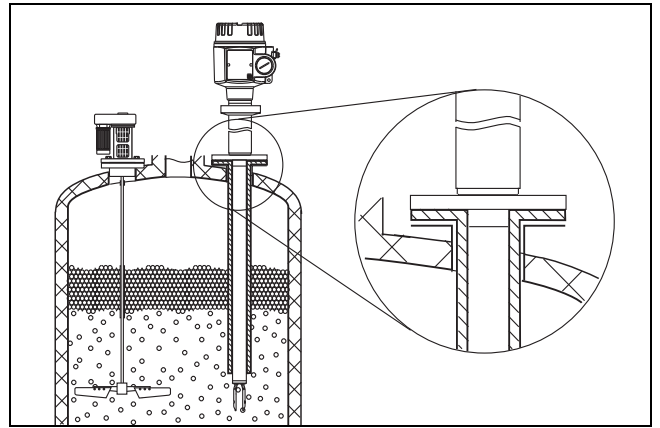

L00-FTL7xxxx-11-05-xx-xx-006

Space outside the tank

Ensure that there is adequate space outside the tank for mounting, connection and configuration.

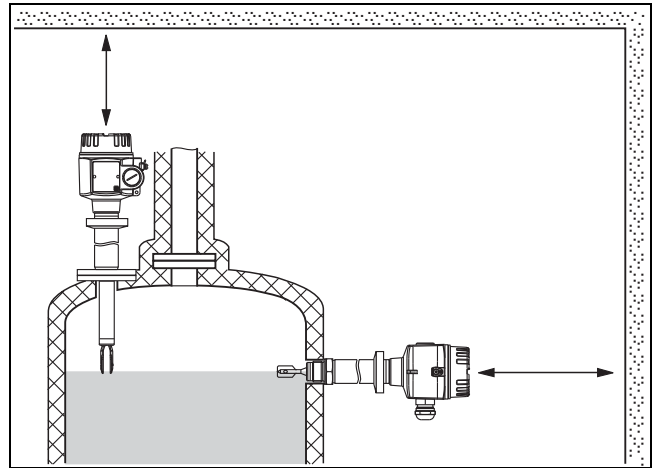

L00-FTL7xxxx-11-05-xx-xx-007

Orientation

FTL70, and FTL71 with short pipe up to approx. 500 mm (19.7 in): in any position,
FTL71 with long pipe: vertical

Environment

Ambient temperature range Permitted ambient temperature T_a at the housing depending on the process temperature T_p in the vessel:

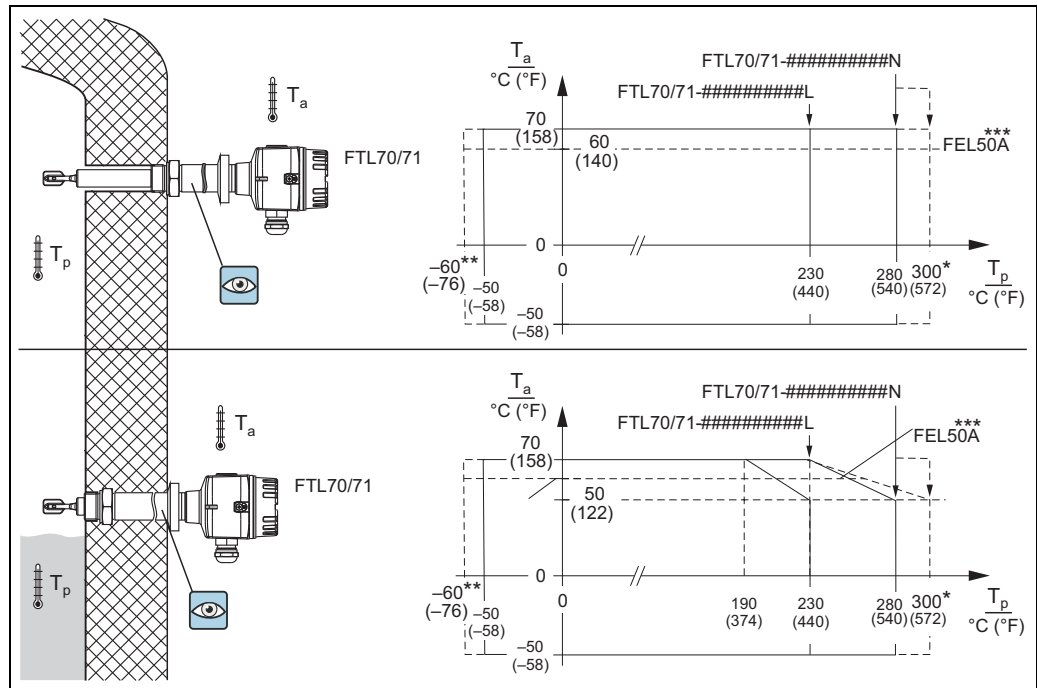

* Maximum of 50 cumulative hours
 ** -60 °C for ATEX and CSA certificates only
 *** FEL50A maximum +60 °C ambient temperature (T_a) in hazardous areas

Ambient temperature limits -50 to +70 °C (-58 to 158 °F)

Storage temperature -50 to +80 °C (-58 to 176 °F)

Installation height as per IEC61010-1 Ed.3 Up to 2000 m (6600 ft) above sea level.

Can be extended up to 3000 m (9800 ft) above sea level if overvoltage protection is used, for example HAW562 or HAW569.

Climate class Climate protection to IEC 68, Part 2-38, Fig. 2a

Degree of protection

Types of housing	IP65	IP66*	IP67*	IP68*	IP69	NEMA4X**
Polyester housing F16	-	X	X	-	-	X
Stainless steel housing F15	-	X	X	-	-	X
Aluminum housing F17	X	X	X	-	-	X
Aluminum housing F13****	X	X	-	X***	-	X
Stainless steel housing F27	-	X	-	X	-	4X/6P
Aluminum housing T13 with separate connection compartment (EEx d)	X	X	-	X***	-	4X/6P

* As per EN60529
 ** As per NEMA 250
 *** Only with M20 cable entry or G1/2 thread
 **** F13 housing only in conjunction with XP or Ex d approval

Vibration resistance As per IEC 68, parts 2-6 (10 to 55 Hz, 0.15 mm (0.01 in), 100 cycles)

Electromagnetic compatibility Interference emission to EN 61326, Electrical Equipment Class B
Interference immunity to EN 61326; Annex A (Industrial) and NAMUR Recommendation NE 21 (EMC)

Process conditions

Process temperature -60 to +280 °C (-76 to 536 °F) and 300 °C (572 °C) for max. 50 cumulative hours

Thermal shock Without restriction within the process temperature range.

Process pressure p_e

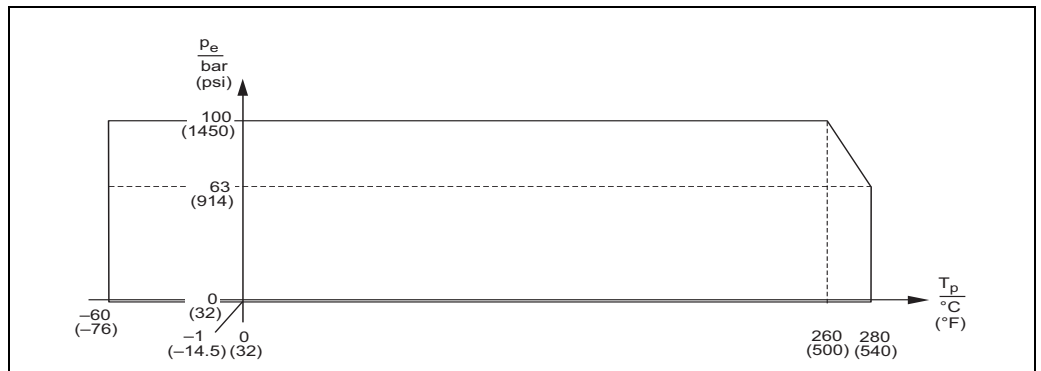

For the pressure values permitted for the flanges in the case of higher temperatures, please refer to the following standards:

- pR EN 1092-1: 2005
With regard to their stability-temperature property, the materials 1.4435 and 1.4404 are identical and are grouped together in EN1092-1 Tab. 18 under 13E0. The chemical composition of the two materials can be identical.
- ASME B 16.5a - 1998 Tab. 2-2.2 F316
- ASME B 16.5a - 1998 Tab. 2.3.8 N10276
- JIS B 2220

The lowest value from the derating curves of the device and selected flange applies in each case.

Test pressure max. 150 bar (2175 psi) at 20 °C (68 °F). The function is not available during test pressure.
Burst pressure of diaphragm 400 bar (5800 psi)

State of aggregation Liquid

Density $\geq 0.7 \text{ g/cm}^3$ (SGU) = delivery status
 $\geq 0.5 \text{ g/cm}^3$ (SGU) can be adjusted via switches

Viscosity $\leq 10,000 \text{ mm}^2/\text{s}$ (cSt)

Solids content $\leq \varnothing 5 \text{ mm}$ (0.2 in)

Lateral loading $\leq 75 \text{ Nm}$

Medium conditions The service life of the device can be affected in applications involving an increased h level of hydrogen diffusion through the metal process isolating diaphragm of the sensor.
Typical conditions: temperature $> 180 \text{ °C}$ ($> 356 \text{ °F}$) and pressure $> 64 \text{ bar}$ ($> 928 \text{ psi}$)



Mechanical construction

Note!

2D and 3D drawings containing individual dimensions can be generated and downloaded in the Configurator on the product pages of the Liquiphant FTL7x at

Design

Summary of all electrical and mechanical versions

Plug-in electronic inserts to mount in the housing

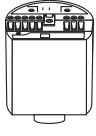
 <small>L00-FTL5xxxx-03-05-xx-xx-000</small>	FEL51:	Two-wire AC connection
	FEL52:	Three-wire DC connection PNP
	FEL54:	Universal current connection, 2 relay outputs
	FEL55:	Output 16/8 mA for separate switching unit
	FEL56:	Output 0.6 to 1.0 / 2.2 to 2.8 mA for separate switching unit (NAMUR)
	FEL58:	Output 2.2 to 3.5 / 0.6 to 1.0 mA for separate switching unit (NAMUR)
	FEL57:	Output 150/50 Hz, PFM, for separate switching unit (Nivotester)
FEL50A:	Digital communication PROFIBUS PA	

Housing

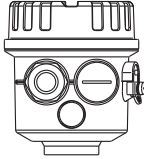
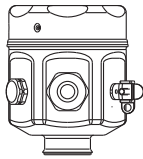
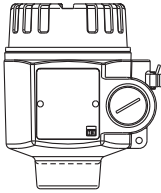
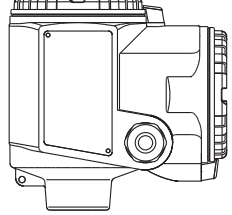
 <small>L00-FTL5xxxx-03-05-xx-xx-001</small>	 <small>L00-FTL5xxxx-03-05-xx-xx-002</small>	 <small>L00-FTL5xxxx-03-05-xx-xx-003</small>	 <small>L00-FTL5xxxx-03-05-xx-xx-004</small>
F16 Polyester (PBT)	F15 Stainless steel (316L)	F13 Aluminum, coated (also for Ex d) F17 Aluminum, coated F27 Stainless steel (316L), (also for Ex d)	T13 Aluminum with separate connection compartment (also Ex de and Ex d), coated

Temperature spacer and pressure-tight feedthrough

Temperature spacer with gas-tight, welded feed-through (standard version)

approx. 160 mm (6.3 in) to 230 °C (446 °F)

Order code ("L")

approx. 200 mm (7.87 in) to 280 °C (536 °F)

Order code ("N")

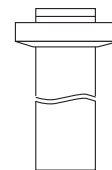

L00-FTL7xxxx-03-05-xx-xx-002

Pressure-tight feedthrough (optional)

Protects the housing from pressures up to 100 bar (1450 psi) if the sensor is damaged. Provides sealed insulation for the vessel and normal ambient temperatures for the housing.

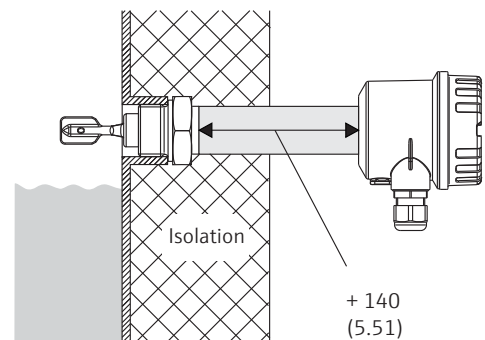

L00-FTL5xxxx-06-05-xx-xx-091

Process connections

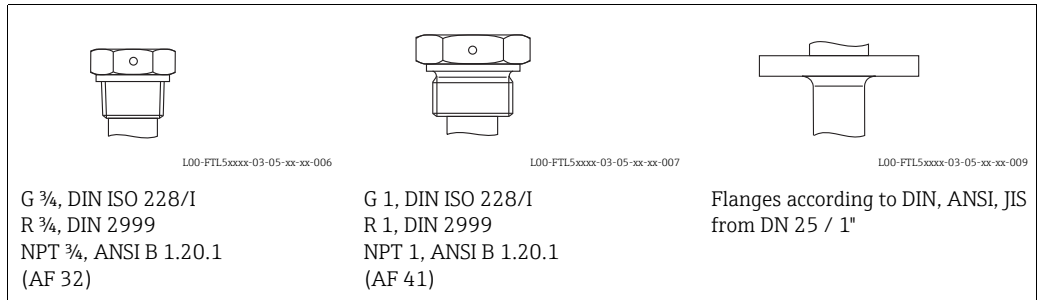

Sensors

Compact or with extension pipe up to 3 m (9.8 in)
(6 m (20 in) on request)

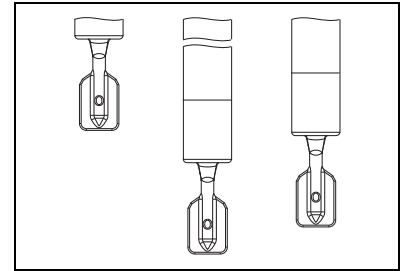

L00-FTL5xxxx-03-05-xx-xx-018

Dimensions

Dimensions in mm (in)!

Housing and sensor FTL70/71

Polyester housing F16

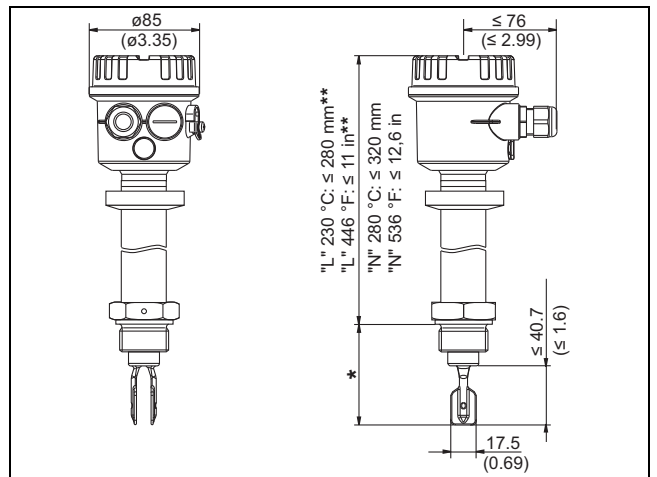

Stainless steel housing F15

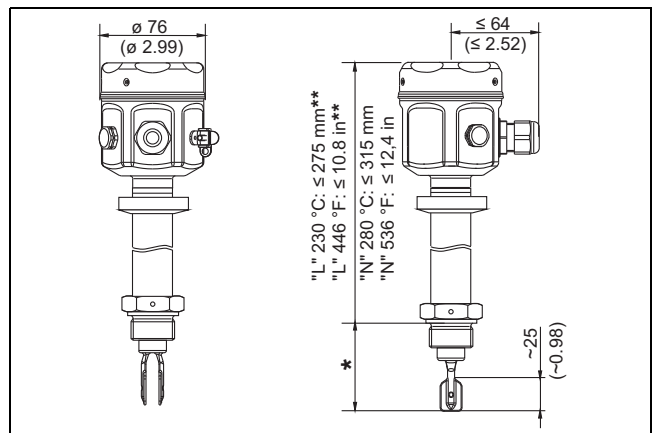

* See process connections

** "L" = version FTL70/71 - ##### L for 230 °C (446 °F)

"N" = version FTL70/71 - ##### N for 280 °C (536 °F)

Aluminum housing F17/F13
 Stainless steel housing (316L) F27
 (F13 also for Ex d)

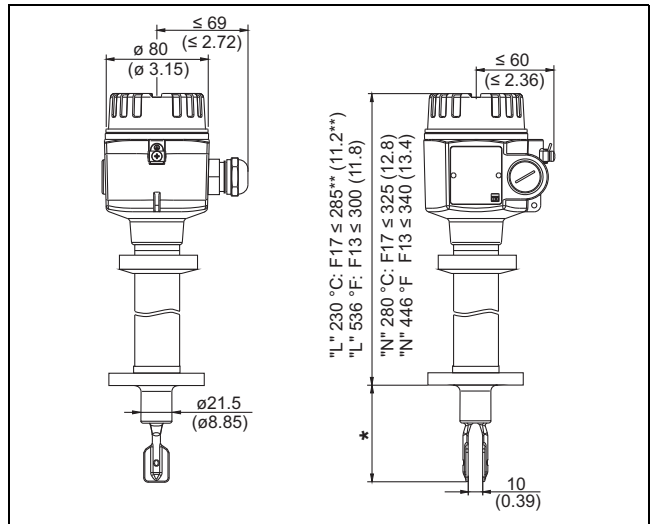

L00-FTL7xxxx-06-05-xx-xx-002

Aluminum housing T13
 with separate connection
 compartment

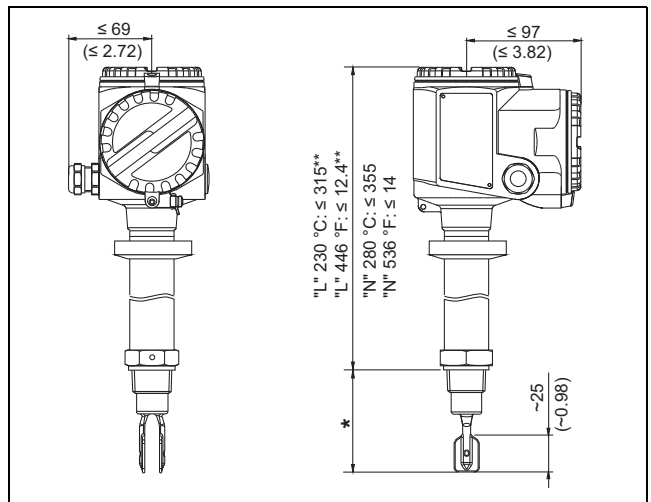

L00-FTL7xxxx-06-05-xx-xx-003

* See process connections

** "L" = version FTL70/71 - ##### L for 230 °C (446 °F)

"N" = version FTL70/71 - ##### N for 280 °C (536 °F)

The dimensions apply to process connections with G, R, NPT threads;
 for versions with flanges, the dimensions may be up to 30 mm (1.18 in) greater.

Process connections

Process connection		Dimensions	Accessories	Pressure Temperature
G 3/4 DIN ISO 228/1	GQ2 GQ6	<p>L00-FTL5xxxx-06-05-xx-xx-092</p>	Flat seal as per DIN 7603; installed on site	≤ 100 bar (≤ 1450 psi) ≤ 280 °C (≤ 536 °F)
G 1 DIN ISO 228/1	GR2 GR6	<p>L00-FTL5xxxx-06-05-xx-xx-094</p>	Flat seal as per DIN 7603; installed on site	≤ 100 bar (≤ 1450 psi) ≤ 280 °C (≤ 536 °F)

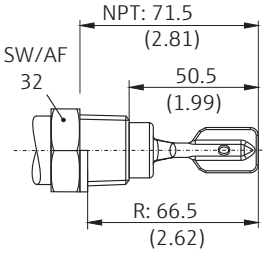
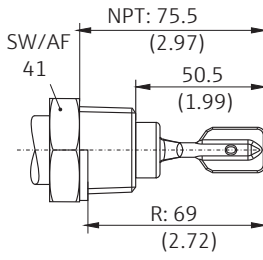
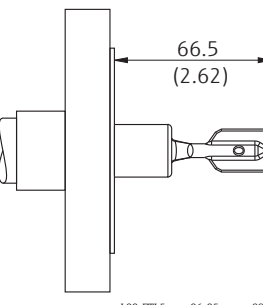
Process connection		Dimensions	Accessories	Pressure Temperature
<p>NPT ¾ ANSI B 1.20.1</p> <p>or</p> <p>R ¾ DIN 2999</p>	<p>GM2 GM6</p> <p>GE2 GE6</p>			<p>≤ 100 bar (≤ 1450 psi)</p> <p>≤ 280 °C (≤ 536 °F)</p>
<p>NPT1 ANSI B 1.20.1</p> <p>or</p> <p>R 1 DIN 2999</p>	<p>GN2 GN6</p> <p>GF2 GF6</p>			<p>≤ 100 bar (≤ 1450 psi)</p> <p>≤ 280 °C (≤ 536 °F)</p>
<p>Flanges ANSI B 16.5 EN 1092-1 (DIN 2527 B) JIS B2220</p>	<p>A## B## C## K##</p>		<p>Seal depending on design; installed on site</p>	<p>See nominal pressure of flange, however ≤ 100 bar (≤ 1450 psi)</p> <p>≤ 280 °C (≤ 536 °F)</p> <p>At high temperatures, note pressure loading capacity of flange depending on temperature!</p>
<p>For higher chemical-resistance, AlloyC22-plated flanges are available. The flange carrier material is made of 316L and is welded with a 2 to 3 mm (0.08 to 0.12 in) thick AlloyC22 disk.</p>				

Sensor length L for FTL71

The sensor length L depends on the process connection.

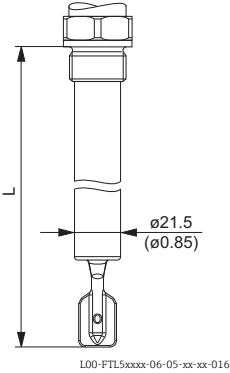
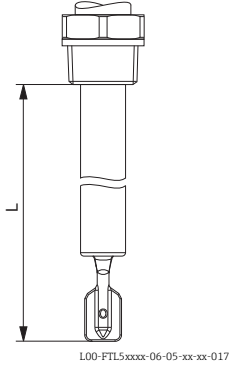
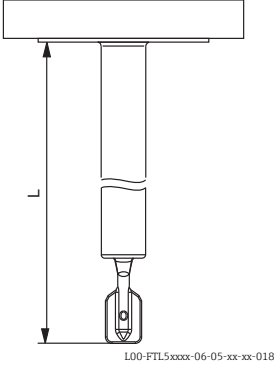
Thread: G ¾ G 1	Thread: NPT ¾ NPT1 R ¾ R 1	Flanges and flange-like process connections
		
From seal surface of thread	From lower edge of thread	

Any length L:

148 mm to 3000 mm (6 to 115 in); special version (TSP) on request up to 6000 mm (235 in)

Weights

See ordering information: → 31

Materials

Material specifications as per AISI and DIN-EN.

Parts in contact with process

- Process connection and extension pipe: 316L (1.4435) optional 2.4602 (AlloyC22)
- Tuning fork: S31803 (1.4462) optional 2.4602 (AlloyC22)
- Flanges: 316L (1.4404)
- Flange plating: AlloyC22

Parts with no process contact

- Tuning fork/housing seal: EPDM
- Temperature spacer: 316 L (1.4435)
- Pressure-tight feedthrough: 316L (1.4435)
- Ground terminals at housing (external): 304 (1.4301)
- Nameplate on housing (external): 304 (1.4301)
- Cable glands
 - Housing F13, F15, F16, F17: polyamide (PA)
 - With B or C approval (→ 31 ordering information): nickel-plated brass
 - Housing F27: 316L (1.4435)
 - Housing T13: nickel-plated brass
- Polyester housing F16: PBT-FR with PBT-FR cover or with PA12 transparent cover,
 - Cover seal: EPDM
 - Nameplate glued: polyester film (PET)
 - Pressure compensation filter: PBT-GF20
- Stainless steel housing F15: 316L (1.4404)
 - Cover seal: silicone
 - Safety claw: 304 (1.4301)
 - Pressure compensation filter: PBT-GF20, PA
- Aluminum housing F17/F13: EN-AC-ALSi10Mg, plastic-coated,
 - Cover seal: EPDM
 - Safety claw: nickel-plated brass
 - Pressure compensation filter: silicone
- Stainless steel housing F27: 316L (1.4435)
 - Cover seal: FVMQ (optional: EPDM seal available as spare part)
 - Safety claw: 316L (1.4435)

- Aluminum housing T13: EN-AC-ALSi10Mg, plastic-coated,
 - Cover seal: EPDM
 - Safety claw: nickel-plated brass

Process connections

- Parallel thread G ¾, G 1 as per DIN ISO 228/1, flat seal as per DIN 7603, installed on site
- Tapered thread R ¾, R 1 as per DIN 2999 Part 1
- Tapered thread ¾ -14 NPT, 1 - 1½ NPT as per ANSI B 1.20.1
- Flanges (for standards, see also Ordering information → 31+):
 - as per EN/DIN from DN 25
 - as per ANSI B16.5 from 1"
 - as per JIS B2220 (RF)

Operability

Electronic inserts

With FEL51, FEL52, FEL54, FEL55:

- 2 switches for fail-safe circuit and density change,
- green LED to indicate operational status,
- red LED to indicate switching status, flashes in the event of corrosion damage on sensor or if the electronics are defective

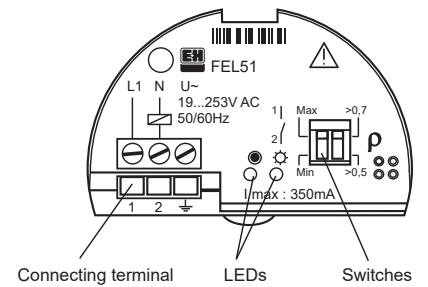

L00-FTL5xxxx-03-05-xx-en-001

With FEL56:

- 2 switches for fail-safe circuit and density change,
- green LED flashes to indicate operational status,
- red LED to indicate switching status, flashes in the event of corrosion damage on sensor or if the electronics are defective

With FEL57:

- 2 switches for density change and proof testing,
- green LED to indicate operational status,
- yellow LED to indicate covered status, flashes in the event of corrosion damage on sensor or if the electronics are defective



L00-FTL5xxxx-03-05-xx-xx-013

With FEL58:

- 2 switches for fail-safe circuit and density change,
- green LED
 - flashes quickly to indicate operational status
 - flashes slowly in the event of corrosion damage on sensor or if the electronics are defective,
- yellow LED to indicate switching status, test key
 - breaks cable connection

With FEL50A:

- 8 switches for configuring device address
- green LED to indicate operational status, pulsing to indicate communication;
- yellow LED to indicate switching status, flashes in the event of corrosion damage on sensor or if the electronics are defective

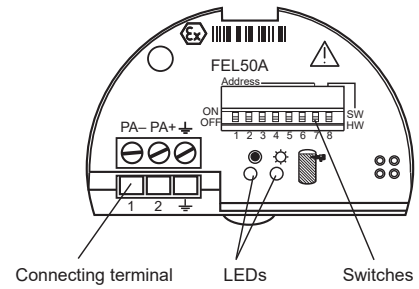

L00-FTL5xxxx-03-05-xx-en-002

Operating concept

Onsite configuration

Certificates and approvals

CE mark	The measuring system meets the legal requirements of the applicable EC Directives. These are listed in the corresponding EC Declaration of Conformity along with the standards applied. confirms successful testing of the device by affixing to it the CE mark.
RoHS	The measuring system complies with the substance restrictions of the EU Directive on the restriction of the use of certain hazardous substances 2011/65/EU (RoHS 2).
RCM-tick mark	The product or measuring system supplied complies with the regulations of the Australian Communications and Media Authority (ACMA) for network integrity, performance characteristics and health and safety requirements. The specifications for electromagnetic compatibility, in particular, are observed. The products bear the RCM-tick mark on their nameplate.



A0029561

Other certificates	<ul style="list-style-type: none"> ■ See Ordering information Liquiphant S FTL70 FTL71 → 31 ■ Leak-detection system in conjunction with WHG approval Approval number: Z-65.40-446 (See also "Ordering information" → 31) ■ TSE Certificate of Suitability The following applies to wetted device components: <ul style="list-style-type: none"> - They do not contain any materials derived from animals. - No additives or operating materials derived from animals are used in production or processing. <p> Note! Wetted device components are listed in the "Mechanical construction" (→ 22+) and "Ordering information" (→ 31) sections.</p>
---------------------------	--

EAC conformity	<p>The measuring system meets the legal requirements of the applicable EAC Directives. These are listed in the corresponding EAC Declaration of Conformity along with the standards applied.</p> <p>confirms successful testing of the device by affixing to it the EAC mark.</p>
-----------------------	---

CRN approval	Device versions available with CRN approval: 0F10904.5C (Canadian Registration Number) are marked with a "*" in feature 20 "Process connection" under Ordering information (31+). Further details on maximum pressure values are available in the Download area of the product pages
---------------------	--

Process seal according to ANSI/ISA 12.27.01

Practice in North America for the installation of process seals devices are designed as either single seal or dual seal devices with an alarm in accordance with ANSI/ISA 12.27.01. This means that the user does need to install for an external secondary process seal in the thermowell which is required in ANSI/NFPA 70 (NEC) and CSA 22.1 (CEC). These devices comply with installation practice in North America and enable very safe, low-cost installation in pressurized applications with hazardous media.

Further information is provided in the Safety Instructions (XA) for the specific device → 39 ff.

Product	Listing	Type	Max. process pressure	Marking
Liquiphant M	CSA	FTL70-S/T##...	64/100 bar	Single Seal
	FM	FTL70-P/Q/R##...	(928/1450 psi)	
	CSA	FTL71-S/T##...	64/100 bar	Single Seal
	FM	FTL71-P/Q/R##...	(928/1450 psi)	

Pressure Equipment Directive 2014/68/EU (PED)**Pressure instruments with permitted pressure ≤ 200 bar (2 900 psi)**

Pressure instruments with permitted pressure ≤ 200 bar (2 900 psi) Pressure instruments with a flange and threaded boss that do not have a pressure-bearing housing do not fall within the scope of the Pressure Equipment Directive, irrespective of the maximum permitted pressure.

Reason:

According to Article 2, point 5 of EU Directive 2014/68/EU, pressure accessories are defined as "devices with an operational function and having pressure-bearing housings".

If a pressure instrument does not have a pressure-bearing housing (no identifiable pressure chamber of its own), there is no pressure accessory present within the meaning of the Directive.

Use in hazardous zones

Pay particular attention to the information provided in the documentation: Safety Instructions, Control Drawings etc. → 39

ASME B 31.3

Design and materials in accordance with ASME B31.3 The welding seals are through-penetration welded and comply with ASME Boiler and Pressure Vessel Code Section IX and EN ISO 15614-1.

Combinations of housing and electronic inserts

For permitted combinations of housing versions and electronic inserts, see the safety instructions for ATEX, NEPSI etc.. A list of available documents can be found on  39+. The actual documents are available on the product pages at

Abbreviations used:

Housing	Electronic inserts
Polyester housing F16	FEL50A Profibus PA
Aluminum housing F17 (plug-in)	FEL51 SIL 2-wire 19-253VDC
Aluminum housing F13 (thread)	FEL52 3-wire PNP
Aluminum housing T13 (separate connection compartment)	FEL54 relay DPDT 19-253VAC/19-55VDC
Stainless steel housing F15 (for hygiene applications)	FEL55 8/16mA, 11-36VDC
Stainless steel housing F27 (precision casting)	FEL56 NAMUR (L-H signal)
	FEL57 2-wire PFM
	FEL58 NAMUR+test key (H-L signal)

A:	Non-hazardous area	F16, F17, F13, T13, F15, F27	FEL51/52/54 FEL50A/55/56/57/58
B:	ATEX/NEPSI II 3G EEx nC II T6, WHG	F16, F17, F13, T13, F15, F27	FEL54
C:	ATEX/NEPSI II 3G EEx nA II T6, WHG	F16, F17, F13, T13, F15, F27	FEL51/52 FEL50A/55/56/57/58
D:	Non-hazardous area, WHG	F16, F17, F13, T13, F15, F27	FEL51/52/54 FEL50A/55/56/57/58
E:	ATEX II 1/2G EEx de IIC T6, WHG/ IEC Zone 0/1	T13	FEL51/52/54 FEL50A/55/56/57/58
F:	ATEX II 1/2GD Ex ia IIC T6, WHG/ IEC	F17, F13, T13, F15, F27	FEL50A/55/56/57/58
L:	ATEX II 1/2G EEx d IIC T6, WHG/ IECE Zone 0/1	F13, T13, F27	FEL51/52/54 FEL50A/55/56/57/58
M:	NEPSI Ex ia IIC T6	F16, F17, F13, T13, F15, F27	FEL50A/55/56/57/58
N:	NEPSI Ex d IIC T6	F13, T13, F27	FEL51/52/54 FEL50A/55/56/57/58
P:	FM IS Cl.I, II, III Div.1 Gr.A-G, Zone 0, 1, 2, 20, 21, 22	F16, F17, F13, T13, F15, F27 (with NPT cable entry)	FEL50A/55/56/57/58
Q:	FM XP Cl.I, II, III Div.1 Gr.A-G, Zone 1, 2, 21, 22	F13, T13, F27	FEL51/52/54 FEL50A/55/56/57/58
R:	FM NI Cl.I Div.2 Gr.A-D, Zone 2	F16, F17, F13, T13, F15, F27	FEL51/52/54 FEL50A/55/56/57/58
S:	CSA IS Cl I, II, III Div.1 Gr.A-G, Zone 0, 1, 2	F16, F17, F13, T13, F15, F27 (with NPT cable entry)	FEL50A/55/56/57/58
T:	CSA XP Cl I, II, III Div.1 Gr.A-G, Zone 1, 2	F13, T13, F27	FEL51/52/54 FEL50A/55/56/57/58
U:	CSA General Purpose	F16, F17, F13, T13, F15, F27	FEL51/52/54 FEL50A/55/56/57/58
V:	TIIS Ex ia IIC T2	F16, F17, F13, T13, F15, F27	FEL50A/55/56/57/58
W:	TIIS Ex d IIC T2	F13, T13, F27	FEL51/52/54 FEL50A/55/56/57/58
Y:	Other certificate (for non-hazardous areas)		



Note! Polyester housing F16 (PBT)

Electrical connecting cables run in pipes:

- Do not screw cable entries firmly to the piping. Use flexible connections (e.g. with armored hose).
- If piping is used for grounding, ensure that there is a continuous electrical connection.

Ordering information

Detailed ordering information is available from the following sources:

- In the Product Configurator on the website: → Click "Corporate"
→ Select your country → Click "Products" → Select the product using the filters and search mask → Open the product page → The "Configuration" button to the right of the product image opens the Product Configurator.
Product Configurator - the tool for individual product configuration
- Up-to-the-minute configuration data
- Depending on the device: direct input of information specific to measuring point, such as measuring range or operating language
- Automatic verification of exclusion criteria
- Automatic creation of the order code and its breakdown in PDF or Excel output format
- Ability to order directly from the

Versions that are mutually exclusive are not indicated in this table.

Ordering information Liquiphant S FTL70 FTL71

Design:				<i>Basic weight</i>
FTL70	Compact			0.7 kg
FTL71	With extension pipe			0.7 kg
10	Approval:			
A	Non-hazardous area			
B	ATEX/NEPSI II 3 G	EEx nC II T6	Overfill protection as per WHG	
C	ATEX/NEPSI II 3 G	EEx nA II T6	Overfill protection as per WHG	
D	Non-hazardous area			Overfill protection as per WHG
E	ATEX II 1/2 G	EEx de IIC T6	Overfill protection as per WHG, IEC Ex Zone 0/1	
F	ATEX II 1/2 G	EEx ia IIC T6	Overfill protection as per WHG, IEC Ex Zone 0/1	
	ATEX II 1/2 D	T 80°C*		
L	ATEX II 1/2 G	EEx d IIC T6	Overfill protection as per WHG, IEC Ex Zone 0/1	
M	NEPSI	Ex ia IIC T6		
N	NEPSI	Ex d IIC T6		
P	FM	IS, Class I, II, III	Division 1, Group A-G	
Q	FM	XP, Class I, II, III	Division 1, Group B-G, for E5 housing Group A-G	
R	FM	NI, Class I	Division 2, Group A-D	
S	CSA	IS, Class I, II, III	Division 1, Group A-G	
T	CSA	XP, Class I, II, III	Division 1, Group A-G	
U	CSA	General Purpose		
V	TIIS	Ex ia IIC T2		
W	TIIS	Ex d IIC T2		
Y	Special version			
	*) not for PBT			
20	Process connection:			<i>Additional weight</i>
	Threaded connection			
GO2	G ¾		316L	Thread ISO 228
GO6	G ¾		AlloyC22	Thread ISO 228
GR2	G 1		316L	Thread ISO 228
GR6	G 1		AlloyC22	Thread ISO 228
GE2	R ¾		316L	Thread DIN 2999
GE6	R ¾		AlloyC22	Thread DIN 2999
GF2	R 1		316L	Thread DIN 2999
GF6	R 1		AlloyC22	Thread DIN 2999
GM2*	NPT ¾		316L	Thread ANSI
GM6	NPT ¾		AlloyC22	Thread ANSI
GN2*	NPT 1		316L	Thread ANSI
GN6	NPT 1		AlloyC22	Thread ANSI
	EN flanges			
B82	DN25	PN25/40 A	316L	Flange EN 1092-1 (DIN 2527 B)
C82	DN25	PN25/40 B1	316L	Flange EN 1092-1 (DIN 2527 C)

20	Process connection:					Additional weight
	C86	DN25	PN25/40 B1	AlloyC22 >1.4462	Flange EN 1092-1 (DIN 2527)	1.3 kg
	D82	DN25	PN40 B1	316L	Flange EN 1092-1 (DIN 2526 D)	1.4 kg
	BB2	DN32	PN25/40 A	316L	Flange EN 1092-1 (DIN 2527 B)	2.0 kg
	BD2	DN40	PN25/40 A	316L	Flange EN 1092-1 (DIN 2527 B)	2.4 kg
	CF2	DN50	PN10/16 B1	316L	Flange EN 1092-1 (DIN 2527 C)	2.5 kg
	BG2	DN50	PN25/40 A	316L	Flange EN 1092-1 (DIN 2527 B)	3.2 kg
	CG2	DN50	PN25/40 B1	316L	Flange EN 1092-1 (DIN 2527 C)	2.9 kg
	DG2	DN50	PN40 B1	316L	Flange EN 1092-1 (DIN 2526 D)	2.9 kg
	CG6	DN50	PN25/40 B1	AlloyC22 >1.4462	Flange EN 1092-1 (DIN 2527)	2.9 kg
	BI2	DN50	PN63 A	316L	Flange EN 1092-1 (DIN 2527 B)	4.5 kg
	CI2	DN50	PN63 B2	316L	Flange EN 1092-1 (DIN 2527 E)	4.5 kg
	CI6	DN50	PN63 B1	AlloyC22 >1.4462	Flange EN 1092-1 (DIN 2527)	4.5 kg
	BJ2	DN50	PN100 A	316L	Flange EN 1092-1	5.5 kg
	CJ2	DN50	PN100 B2	316L	Flange EN 1092-1	5.5 kg
	BK2	DN65	PN25/40 A	316L	Flange EN 1092-1 (DIN 2527 B)	4.3 kg
	CM2	DN80	PN10/16 B1	316L	Flange EN 1092-1 (DIN 2527 C)	4.8 kg
	BN2	DN80	PN25/40 A	316L	Flange EN 1092-1 (DIN 2527 B)	5.9 kg
	CN2	DN80	PN25/40 B1	316L	Flange EN 1092-1 (DIN 2527 C)	5.2 kg
	DN2	DN80	PN40 B1	316L	Flange EN 1092-1 (DIN 2526 D)	5.2 kg
	CN6	DN80	PN25/40 B1	AlloyC22 >1.4462	Flange EN 1092-1 (DIN 2527)	5.2 kg
	B02	DN80	PN63 A	316Ti	Flange EN 1092-1 (DIN 2527 B)	6.9 kg
	C02	DN80	PN63 B2	316L	Flange EN 1092-1 (DIN 2527 E)	6.9 kg
	C06	DN80	PN63 B1	AlloyC22 >1.4462	Flange EN 1092-1 (DIN 2527)	6.9 kg
	B12	DN80	PN100 A	316L	Flange EN 1092-1	8.0 kg
	C12	DN80	PN100 B2	316L	Flange EN 1092-1	8.0 kg
	CO2	DN100	PN10/16 B1	316L	Flange EN 1092-1 (DIN 2527 C)	5.3 kg
	BR2	DN100	PN25/40 A	316L	Flange EN 1092-1 (DIN 2527 B)	7.5 kg
	BU2	DN100	PN63 A	316L	Flange EN 1092-1 (DIN 2527 B)	10.1 kg
	CU2	DN100	PN63 B2	316L	Flange EN 1092-1 (DIN 2527 E)	10.1 kg
	CU6	DN100	PN63 B1	AlloyC22 >1.4462	Flange EN 1092-1 (DIN 2527)	10.1 kg
	ANSI flanges					
	A82*	1"	150 lbs	RF 316/316L	Flange ANSI B16.5	1.0 kg
	AB2*	1¼"	300 lbs	RF 316/316L	Flange ANSI B16.5	2.0 kg
	AC2*	1½"	150 lbs	RF 316/316L	Flange ANSI B16.5	1.5 kg
	AD2*	1½"	300 lbs	RF 316/316L	Flange ANSI B16.5	2.7 kg
	AE2*	2"	150 lbs	RF 316/316L	Flange ANSI B16.5	2.4 kg
	AE6	2"	150 lbs	RF AlloyC22 >1.4462	Flange ANSI B16.5	2.4 kg
	AF2*	2"	300 lbs	RF 316/316L	Flange ANSI B16.5	3.2 kg
	AF6	2"	300 lbs	RF AlloyC22 >1.4462	Flange ANSI B16.5	3.2 kg
	AG2*	2"	600 lbs	RF 316/316L	Flange ANSI B16.5	4.2 kg
	AG6	2"	600 lbs	RF AlloyC22 >1.4462	Flange ANSI B16.5	4.2 kg
	AL2*	3"	150 lbs	RF 316/316L	Flange ANSI B16.5	4.9 kg
	AM2*	3"	300 lbs	RF 316/316L	Flange ANSI B16.5	6.8 kg
	AN2*	3"	600 lbs	RF 316/316L	Flange ANSI B16.5	8.5 kg
	AN6	3"	600 lbs	RF AlloyC22 >1.4462	Flange ANSI B16.5	8.5 kg
	AP2*	4"	150 lbs	RF 316/316L	Flange ANSI B16.5	7.0 kg

20		Process connection:					Additional weight
	AQ2*	4"	300 lbs	RF	316/316L	Flange ANSI B16.5	11.5 kg
	AR2*	4"	600 lbs	RF	316/316L	Flange ANSI B16.5	17.3 kg
		JIS flanges					
	KF2	20 K 50		RF	316L	Flange JIS B2220	1.9 kg
	KF6	20 K 50		RF	AlloyC22 >316L	Flange JIS B2220	1.9 kg
	YY9	Special version					
	* With CRN approval.						
30		Probe length:					
	FTL70						
	AB	Compact version			Ra < 3.2 µm/80 grit,	316L	
		Fork: 318L					
	AE	Compact version			Ra < 3.2 µm/80 grit,	Alloy	
	FTL71						
	BB mm L			Ra < 3.2 µm/80 grit,	316L	
		Fork: 318L					0.9 kg/m
	BE mm L			Ra < 3.2 µm/80 grit,	Alloy	0.9 kg/m
	CB inch L			Ra < 3.2 µm/80 grit,	316L	
		Fork: 318L					2.3 kg/100 in
	CE inch L			Ra < 3.2 µm/80 grit,	Alloy	2.3 kg/100 in
	YY	Special version					
40		Electronics; output:					
	A	FEL50A;	PROFIBUS PA				
	1	FEL51;	SIL 2-wire		19 to 253 V AC		
	2	FEL52;	SIL 3-wire PNP		10 to 55 V DC		
	4	FEL54;	SIL relay DPDT		19 to 253 V AC/19 to 55 V DC		
	5	FEL55;	SIL 8/16 mA		11 to 36 V DC		
	6	FEL56;	SIL NAMUR (L-H signal)				
	7	FEL57;	SIL 2-wire PFM				
	8	FEL58;	SIL NAMUR + test keys (H-L signal)				
	9	Special version					
50		Housing; cable entry:					
	E1*	F27 316L		NEMA6P;		Thread NPT ¾	
	E4	F16 Polyester		NEMA4X;		Thread NPT ½	
	E5	F17 Alu		NEMA4X;		Thread NPT ¾	0.5 kg
	E7	T13 Alu		coated IP66;		Thread NPT ¾	
		Separate connection compartment					1.1 kg
	E8	F13 Alu		NEMA4X;		Thread NPT ¾	
		suitable for EEx d/XP					0.5 kg
	F1*	F27 316L		IP68		Thread G1/2	
	F4	F16 Polyester		IP66;		Thread G ½	
	F5	F17 Alu		IP66;		Thread G ½	0.5 kg
	F7	T13 Alu		coated IP66;		Thread G ½	
		Separate connection compartment					1.1 kg
	F8	F13 Alu		IP68;		Thread G ½	
		suitable for EEx d/XP					0.5 kg
	G1*	F27 316L		IP68;		M20 threaded joint	
	G4	F16 Polyester		IP66;		M20 threaded joint	
	G5	F17 Alu		IP66;		M20 threaded joint	0.5 kg
	G7	T13 Alu		coated IP66;		M20 threaded joint	
		separate connection compartment (EEx d > M20 thread)					1.1 kg
	G8	F13 Alu		IP68;		M20 threaded joint	
		suitable for EEx d/XP					0.5 kg
	N4	F16 Polyester		IP66;		M12 connector	
	N4	F16 Polyester		IP66;		M12 connector	
	N5	F17 Alu		IP66;		M12 connector	
	Y9	Special version					
	* F27 housing under development.						

60	Additional option:								
	A	Basic version							
	C	EN 10204 - 3.1 material (316L/318L wetted) Inspection certificate							
	N	EN 10204 - 3.1 material, NACE MR0175 (316L wetted) inspection certificate							
	S	GL/ABS marine certificate							
	Y	Special version							
70	Application:								
	L	230 °C, gas-tight feed-through							
	N	280 °C, gas-tight feed-through							0.2 kg
	Y	Special version							
FTL7x-									Complete product designation



Note!
The basic weight comprises:

- Sensor (compact)
- Thread G 3/4
- Electronic insert
- Polyester housing

Accessories

Lap joint flange

Order number: 918158-0000
with G 1 thread for mounting a
Liquiphant 51 with GR2 process connection
Pressure up to 40 bar (580 psi)
Material: corrosion-resistant steel
1.4301 (AISI 304)
Weight: 0.54 kg (1.19 lbs)

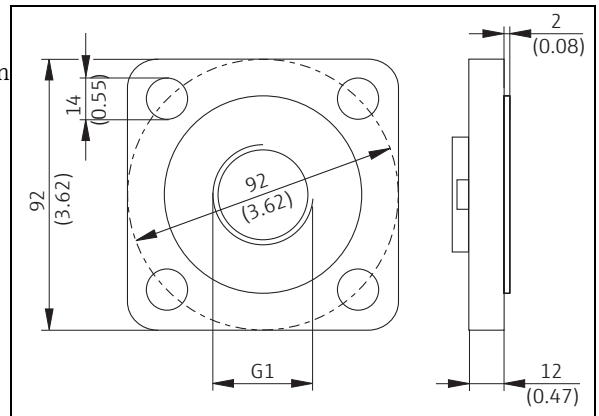

L00-FTL5xxxx-06-05-xx-xx-108

Lap joint flanges

With G 1 thread for mounting
a Liquiphant S FTL70/71
with GR2 process connection.
Material: corrosion-resistant steel
1.4571 (AISI 113Ti)

- Order number: 918143-0000
Flange DN50 PN40, EN 1092-1
Weight: 3.11 kg (6.86 lbs)
- Order number: 918144-0000
Flange ASME 2", 150 psi, RF
Weight: 2.38 kg (5.25 lbs)

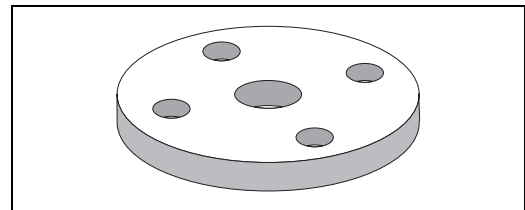

L00-FTL5xxxx-03-05-xx-xx-015

Weather protection cover

For F16 housing

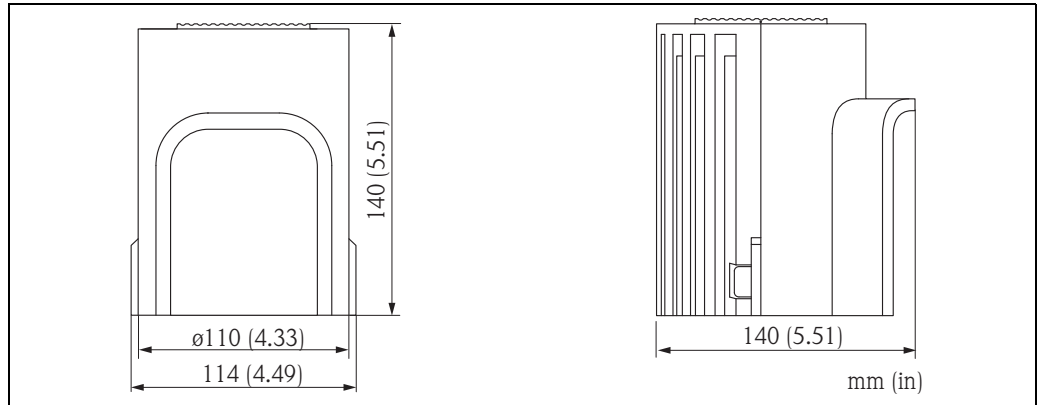

A0018225

Material	Order No.	Weight
PBT, gray	71127760	240 g (8.46 oz)

For F13, F17 and F27 housing

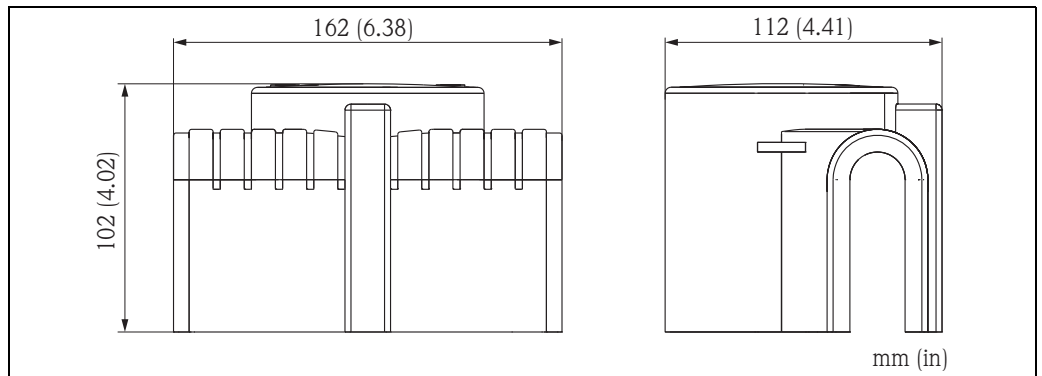

A0018226

Material	Order No.	Weight
PA6, gray	71040497	300 g (10.58 oz)

Sliding sleeves for unpressurized operation

Switch point infinitely variable for Liquiphant MFTL71

Material: corrosion-resistant steel 1.4435 (AISI 316 L)

Weight for G 1, NPT 1: 0.21 kg (0.46 lbs)

Weight for G 1½, NPT 1½: 0.54 kg (1.19 lbs)

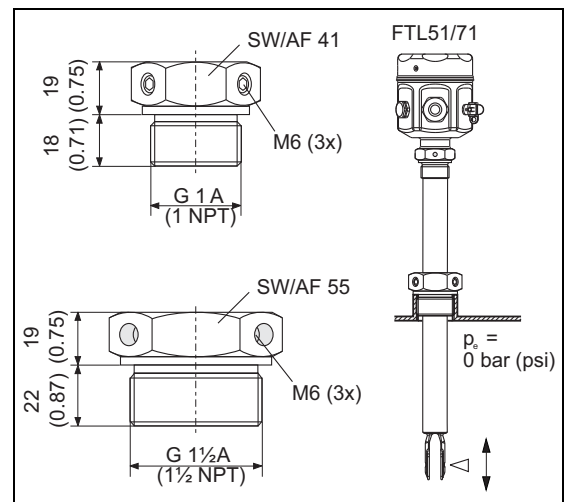

L00-FTL5xxxx-06-05-xx-xx-109

Thread	Standard	Material	Order number	Approval
G 1	DIN ISO 228/1	1.4435 (AISI 316 L)	52003978	
G 1	DIN ISO 228/1	1.4435 (AISI 316 L)	52011888	With inspection certificate EN 10204 - 3.1 material
NPT1	ASME B 1.20.1	1.4435 (AISI 316 L)	52003979	
NPT1	ASME B 1.20.1	1.4435 (AISI 316 L)	52011889	With inspection certificate EN 10204 - 3.1 material
G 1½	DIN ISO 228/1	1.4435 (AISI 316 L)	52003980	
G 1½	DIN ISO 228/1	1.4435 (AISI 316 L)	52011890	With inspection certificate EN 10204 - 3.1 material
NPT1½	ASME B 1.20.1	1.4435 (AISI 316 L)	52003981	
NPT1½	ASME B 1.20.1	1.4435 (AISI 316 L)	52011891	With inspection certificate EN 10204 - 3.1 material

High pressure sliding sleeves

For continuous adjustment of the switch point of a Liquiphant M FTL71.

Also for use in hazardous areas. For further information → 39ff. (ATEX, NEPSI).

Material: corrosion-resistant steel
1.4435 (AISI 316L) or AlloyC22

Weight for G 1, NPT 1: 1.13 kg (2.49 lbs)

Weight for G 1½, NPT 1½: 1.32 kg (2.91 lbs)

Seal package made of graphite.

For G1, G 1½:

Seal is included in the delivery.

Note!

For process pressures up to 100 bar (1450 psi).

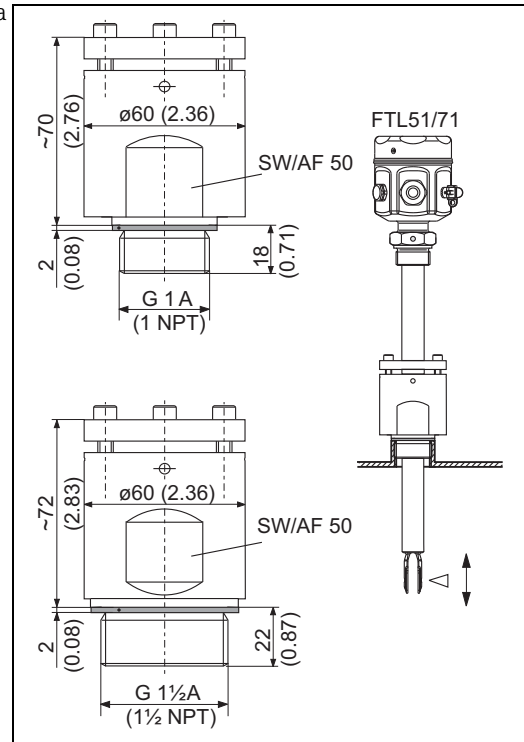

L00-FTL5xxxx-06-05-xx-xx-110

Thread	Standard	Material	Order number	Approval
G 1	DIN ISO 228/1	1.4435 (AISI 316 L)	52003663	
G 1	DIN ISO 228/1	1.4435 (AISI 316 L)	52011880	With inspection certificate EN 10204 - 3.1 material
G 1	DIN ISO 228/1	AlloyC22	71118691	With inspection certificate EN 10204 - 3.1 material
NPT1	ASME B 1.20.1	1.4435 (AISI 316 L)	52003667	
NPT1	ASME B 1.20.1	1.4435 (AISI 316 L)	52011881	With inspection certificate EN 10204 - 3.1 material
NPT1	ASME B 1.20.1	AlloyC22	71118694	With inspection certificate EN 10204 - 3.1 material
G 1½	DIN ISO 228/1	1.4435 (AISI 316 L)	52003665	

Thread	Standard	Material	Order number	Approval
G 1½	DIN ISO 228/1	1.4435 (AISI 316 L)	52011882	With inspection certificate EN 10204 - 3.1 material
G 1½	DIN ISO 228/1	AlloyC22	71118693	With inspection certificate EN 10204 - 3.1 material
NPT1½	ASME B 1.20.1	1.4435 (AISI 316 L)	52003669	
NPT1½	ASME B 1.20.1	1.4435 (AISI 316 L)	52011883	With inspection certificate EN 10204 - 3.1 material
NPT1½	ASME B 1.20.1	AlloyC22	71118695	With inspection certificate EN 10204 - 3.1 material

Pressure and temperature derating of high pressure sliding sleeves

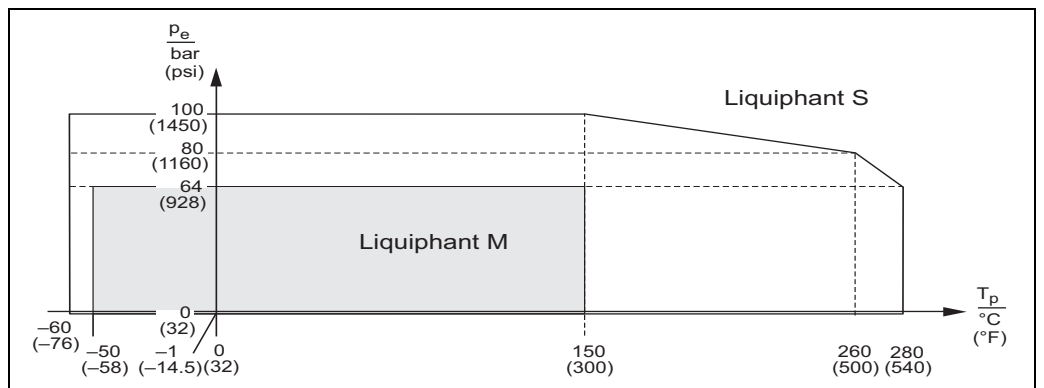

L00-FTL7xxxx-05-05-xx-xx-001

Cover with sight glass

Order number: 943461-0001
 for polyester housing F16
 Material: PA 12
 Weight: 0.04 kg (0.09 lbs)

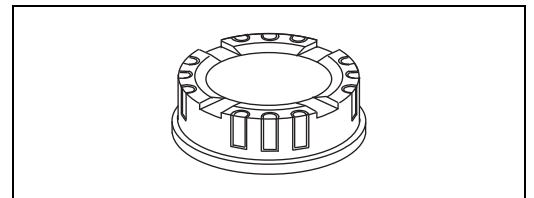

L00-FTL5xxxx-03-05-xx-xx-016

Cover with sight glass

For stainless steel housing F15
 Material: AISI 316L
 Weight: 0.16 kg (0.35 lbs)
 - Order number: 52027002
 With glass sight glass
 - Order number: 52028207
 With PC sight glass
 (Not for CSA, General Purpose)

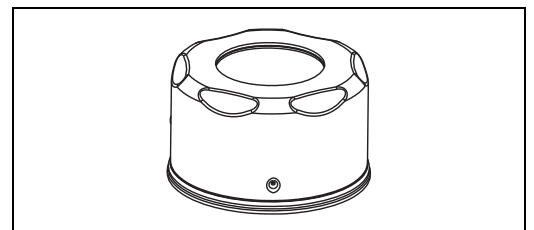

L00-FTL5xxxx-03-05-xx-xx-017

По вопросам продаж и поддержки обращайтесь:

Алматы (7273)495-231
Ангарск (3955)60-70-56
Архангельск (8182)63-90-72
Астрахань (8512)99-46-04
Барнаул (3852)73-04-60
Белгород (4722)40-23-64
Благовещенск (4162)22-76-07
Брянск (4832)59-03-52
Владивосток (423)249-28-31
Владикавказ (8672)28-90-48
Владимир (4922)49-43-18
Волгоград (844)278-03-48
Вологда (8172)26-41-59
Воронеж (473)204-51-73
Екатеринбург (343)384-55-89

Иваново (4932)77-34-06
Ижевск (3412)26-03-58
Иркутск (395)279-98-46
Казань (843)206-01-48
Калининград (4012)72-03-81
Калуга (4842)92-23-67
Кемерово (3842)65-04-62
Киров (8332)68-02-04
Коломна (4966)23-41-49
Кострома (4942)77-07-48
Краснодар (861)203-40-90
Красноярск (391)204-63-61
Курск (4712)77-13-04
Курган (3522)50-90-47
Липецк (4742)52-20-81

Магнитогорск (3519)55-03-13
Москва (495)268-04-70
Мурманск (8152)59-64-93
Набережные Челны (8552)20-53-41
Нижний Новгород (831)429-08-12
Новокузнецк (3843)20-46-81
Ноябрьск (3496)41-32-12
Новосибирск (383)227-86-73
Омск (3812)21-46-40
Орел (4862)44-53-42
Оренбург (3532)37-68-04
Пенза (8412)22-31-16
Петрозаводск (8142)55-98-37
Псков (8112)59-10-37
Пермь (342)205-81-47

Ростов-на-Дону (863)308-18-15
Рязань (4912)46-61-64
Самара (846)206-03-16
Санкт-Петербург (812)309-46-40
Саратов (845)249-38-78
Севастополь (8692)22-31-93
Саранск (8342)22-96-24
Симферополь (3652)67-13-56
Смоленск (4812)29-41-54
Сочи (862)225-72-31
Ставрополь (8652)20-65-13
Сургут (3462)77-98-35
Сыктывкар (8212)25-95-17
Тамбов (4752)50-40-97
Тверь (4822)63-31-35

Тольятти (8482)63-91-07
Томск (3822)98-41-53
Тула (4872)33-79-87
Тюмень (3452)66-21-18
Ульяновск (8422)24-23-59
Улан-Удэ (3012)59-97-51
Уфа (347)229-48-12
Хабаровск (4212)92-98-04
Чебоксары (8352)28-53-07
Челябинск (351)202-03-61
Череповец (8202)49-02-64
Чита (3022)38-34-83
Якутск (4112)23-90-97
Ярославль (4852)69-52-93

Россия +7(495)268-04-70

Казахстан +7(7172)727-132

Киргизия +996(312)96-26-47

эл.почта: ehr@nt-rt.ru || сайт: <https://endcounters.nt-rt.ru/>