

Датчики температуры MLTWS01

Техническая информация

По вопросам продаж и поддержки обращайтесь:

Алматы (7273)495-231
Ангарск (3955)60-70-56
Архангельск (8182)63-90-72
Астрахань (8512)99-46-04
Барнаул (3852)73-04-60
Белгород (4722)40-23-64
Брянск (4832)59-03-52
Владивосток (423)249-28-31
Владикавказ (8672)28-90-48
Владимир (4922)49-43-18
Волгоград (844)278-03-48
Вологда (8172)26-41-59
Воронеж (473)204-51-73
Екатеринбург (343)384-55-89

Иваново (4932)77-34-06
Ижевск (3412)26-03-58
Иркутск (395)279-98-46
Казань (843)206-01-48
Калининград (4012)72-03-81
Калуга (4842)92-23-67
Кемерово (3842)65-04-62
Киров (8332)68-02-04
Коломна (4966)23-41-49
Кострома (4942)77-07-48
Краснодар (861)203-40-90
Красноярск (391)204-63-61
Курск (4712)77-13-04
Курган (3522)50-90-47
Липецк (4742)52-20-81

Магнитогорск (3519)55-03-13
Москва (495)268-04-70
Мурманск (8152)59-64-93
Набережные Челны (8552)20-53-41
Нижний Новгород (831)429-08-12
Новокузнецк (3843)20-46-81
Ноябрьск (3496)41-32-12
Новосибирск (383)227-86-73
Омск (3812)21-46-40
Орел (4862)44-53-42
Оренбург (3532)37-68-04
Пенза (8412)22-31-16
Петрозаводск (8142)55-98-37
Псков (8112)59-10-37
Пермь (342)205-81-47

Ростов-на-Дону (863)308-18-15
Рязань (4912)46-61-64
Самара (846)206-03-16
Санкт-Петербург (812)309-46-40
Саратов (845)249-38-78
Севастополь (8692)22-31-93
Ставрополь (8652)20-65-13
Симферополь (3652)67-13-56
Смоленск (4812)29-41-54
Сочи (862)225-72-31
Ставрополь (8652)20-65-13
Сургут (3462)77-98-35
Сыктывкар (8212)25-95-17
Тамбов (4752)50-40-97
Тверь (4822)63-31-35

Тольятти (8482)63-91-07
Томск (3822)98-41-53
Тула (4872)33-79-87
Тюмень (3452)66-21-18
Ульяновск (8422)24-23-59
Улан-Удэ (3012)59-97-51
Уфа (347)229-48-12
Хабаровск (4212)92-98-04
Чебоксары (8352)28-53-07
Челябинск (351)202-03-61
Череповец (8202)49-02-64
Чита (3022)38-34-83
Якутск (4112)23-90-97
Ярославль (4852)69-52-93

Россия +7(495)268-04-70

Казахстан +7(7172)727-132

Киргизия +996(312)96-26-47

эл.почта: ehr@nt-rt.ru || сайт: <https://endcounters.nt-rt.ru/>

Technical Information

MLTWS01

Thermometer thermowell for use in the Oil & Gas industry

Thermowell fabricated from welded tubes
Flanged process connection



Application

The thermowell is designed for use in the Oil & Gas industry but can also be used for general applications. Modular configuration enables a use in all industrial processes with severe thermal and mechanical stresses.

Your benefits

- Thermowell fabricated from welded tubes.
- The process connection is flanged.
- Extension, immersion length and total length can be chosen according to process requirements.
- Special versions can be manufactured according to customer requirements.

Function and system design

Equipment architecture

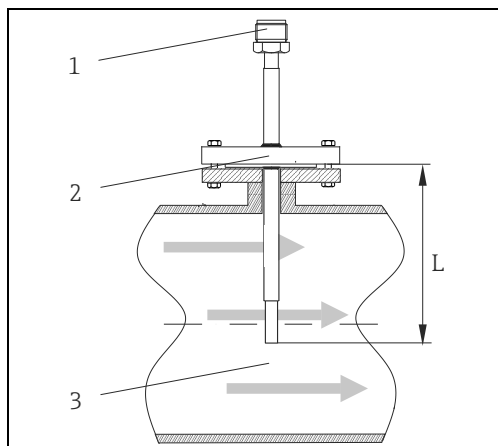

The device can guarantee a good level of resistance to the most typical and common industrial processes. It is made from a pipe with a diameter 16x3 mm (0.63x0.12 in). The thermowell with reduced tip will be fitted on the plant (pipe or vessel) using a flanged process connection.

Thermowell installation

- 1 Thread M24x1.5
 2 Process connection: flange
 3 Plant pipe with flowing process medium
 L Thermowell immersion length

Performance characteristics

Operating conditions

Process pressure

The pressure values to which the thermowell can be subjected at the various temperatures and maximum permitted flow velocity, can be calculated online in the thermowell calculation tool: 'Sizing Thermowell'. Occasionally, the pressure loading capacity of the process connection can be considerably lower. The maximum allowable process pressure for a specific thermometer is derived from the lower pressure value of the thermowell and process connection.

Maximum process pressure for the process connection:

Process connection	Standard	Maximum process pressure
Flange	EN1092-1	<ul style="list-style-type: none"> ▪ DN25 PN40 B1: 40 bar (580 psi) at 20 °C (68 °F) ▪ DN25 PN63 B2: 63 bar (914 psi) at 20 °C (68 °F)

Maximum flow velocity

The highest flow velocity tolerated by the thermowell diminishes with increasing immersion length exposed to the stream of the fluid. Detailed calculation of the flow velocity can be done online in the thermowell calculation tool: 'Sizing Thermowell'.

Material

Thermowell and process connections.

The temperatures for continuous operation specified in the following table are only intended as reference values for use of the various materials in air and without any significant compressive load. The maximum operation temperatures are reduced considerably in some cases where abnormal conditions such as high mechanical load occur or in aggressive media.

Material name	Short form	Recommended max. temperature for continuous use in air	Properties
AISI 316Ti/1.4571	X6CrNiMoTi17-12-2	700 °C (1292 °F)	<ul style="list-style-type: none"> ▪ Austenitic, stainless steel ▪ High corrosion resistance in general ▪ Particularly high corrosion resistance in chlorine-based and acidic, non-oxidizing atmospheres through the addition of molybdenum (e.g. phosphoric and sulfuric acids, acetic and tartaric acids with a low concentration) ▪ Increased resistance to intergranular corrosion and pitting ▪ Addition of titanium means increased resistance to intergranular corrosion even after welding ▪ Broad range of uses in the chemical, petrochemical and oil industries as well as in coal chemistry ▪ Can only be polished to a limited extent, titanium streaks can form

Mechanical construction

Design, dimensions

All dimensions in mm (in).

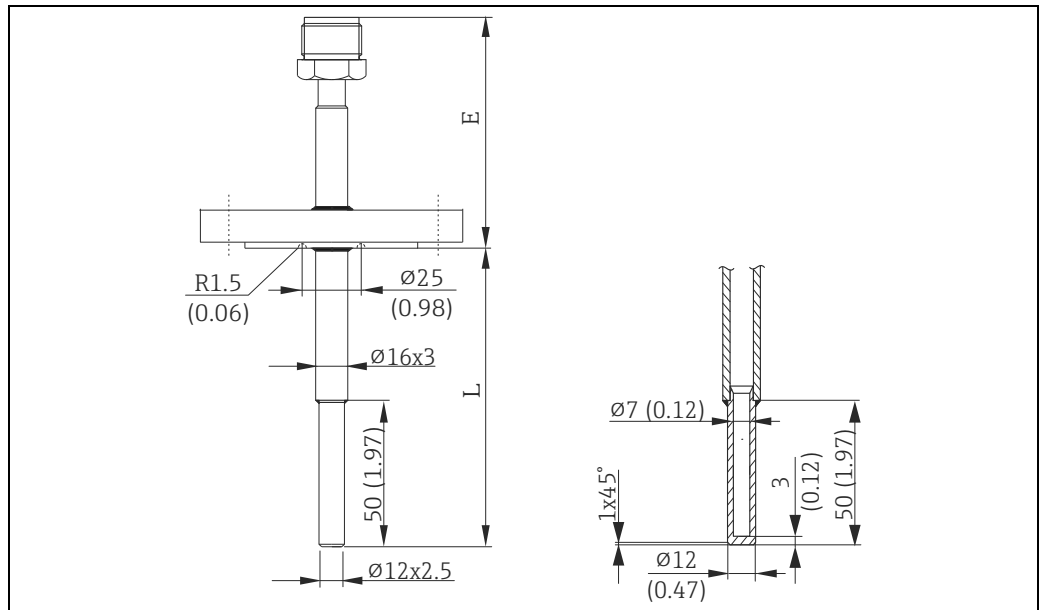

Thermowell dimensions and tip shape

E Neck length
 L Immersion length

Thermowell type	L in mm (in)	E in mm (in)	DN standard pipe sizes
1	235 (9.25)	135 (5.3)	100
2	265 (10.43)	155 (6.1)	150...250
3	325 (12.8)	145 (5.7)	300...500
4	445 (17.5)	125 (4.92)	600...1000

Weight

From 1 to 4 kg (2.2 to 8.8 lbs) for standard options.

Process connection

Available flange connections according to EN 1092-1:

- EN 1092-1, DN25 PN63
- EN 1092-1, DN25 PN40

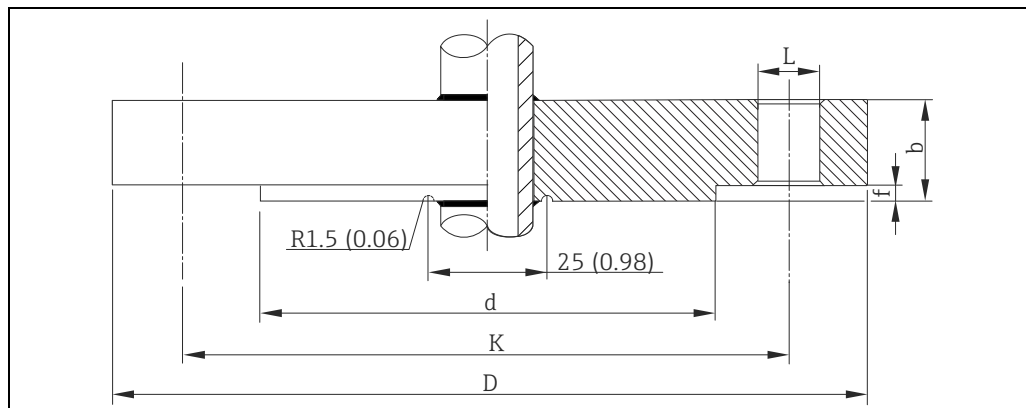

A0022401

Standard flange process connection. Basic dimensions of the available flanges.

Installation conditions**Orientation**

No restrictions.

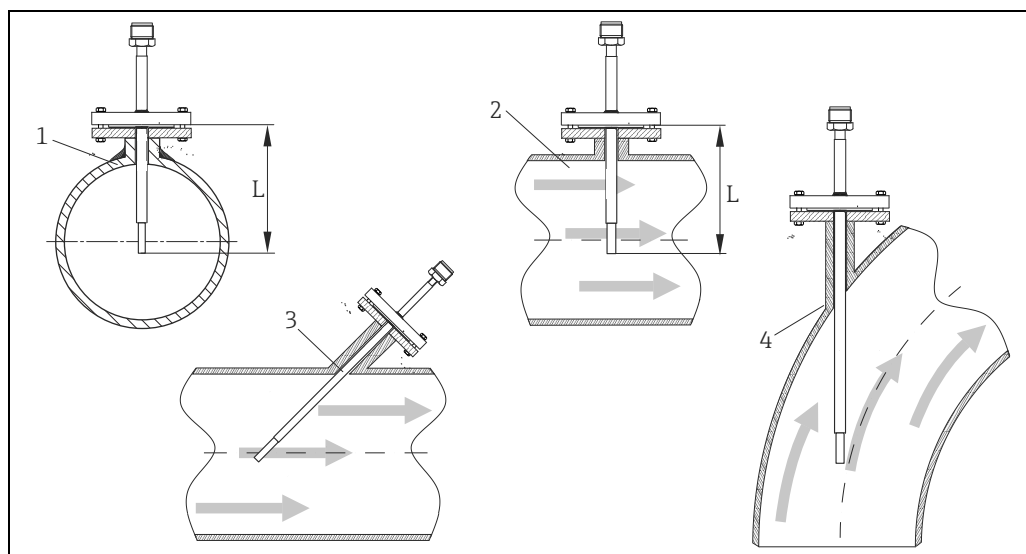
Installation instructions

A0022416

Installation examples

- 1 - 2: In pipes with a small cross section the sensor tip should reach or extend slightly past the center line of the pipe (= L)
 3 - 4: Tilted installation

The immersion length of the thermometer influences the accuracy. If the immersion length is too small then errors in the measurement are caused by heat conduction via the process connection and the container wall. If installing into a pipe then the immersion length should be half of the pipe diameter, if possible (see 1 and 2). A further solution could be an angled (tilted) installation (see 3 and 4). When determining the immersion length all thermometer parameters and the process to be measured must be taken into account (e.g. flow velocity, process pressure).

- Installation possibilities: Pipes, tanks or other plant components
- The immersion length should correspond to at least 8 times of the thermowell diameter.
- ATEX certification: Always take note of the installation regulations!

Certificates and approvals

CE mark

PED approval

The thermowell complies with paragraph 3.3 of the Pressure Equipment Directive (97/23/EC) and is not marked separately.

Material certification

The material certificate 3.1 (according to standard EN 10204) can be directly selected from the sales structure of the product and refers to the parts of the sensor in contact with the process fluid. Other types of certificates related to materials can be requested separately. The "short form" certificate includes a simplified declaration with no enclosures of documents related to the materials used in the construction of the single sensor and guarantees the traceability of the materials through the identification number of the thermometer. The data related to the origin of the materials can subsequently be requested by the client if necessary.

Test on thermowell

Helium leak test as per EN 1779	Leak test for thermowells, welding seams and threaded joints. Depending on the design and size of the thermowell, it can be subjected to helium gas internally or externally. With inspection certificate
Pressure test, external procedure	External and internal pressure to check the pressure resistance and leak-tightness of thermowells, without flanges. With inspection certificate
Positive material identification (PMI) test	Nondestructive material identification and testing of welded joints. Material identification check, X-ray fluorescence analysis With inspection certificate
Load capacity calculation for the thermowell	In accordance with DIN 43772 or ASME PTC19.3 with calculation certificate
Dye penetration test as per ASME V and EN571-1	Suitable for checking welding seam surfaces, e.g. detection of small cracks, etc. With inspection certificate
Radiographic test as per ASME V, VIII, TW welding	With inspection certificate

По вопросам продаж и поддержки обращайтесь:

Алматы (7273)495-231
Ангарск (3955)60-70-56
Архангельск (8182)63-90-72
Астрахань (8512)99-46-04
Барнаул (3852)73-04-60
Белгород (4722)40-23-64
Брянск (4832)59-03-52
Владивосток (423)249-28-31
Владикавказ (8672)28-90-48
Владимир (4922)49-43-18
Волгоград (844)278-03-48
Вологда (8172)26-41-59
Воронеж (473)204-51-73
Екатеринбург (343)384-55-89

Иваново (4932)77-34-06
Ижевск (3412)26-03-58
Иркутск (395)279-98-46
Казань (843)206-01-48
Калининград (4012)72-03-81
Калуга (4842)92-23-67
Кемерово (3842)65-04-62
Киров (8332)68-02-04
Коломна (4966)23-41-49
Кострома (4942)77-07-48
Краснодар (861)203-40-90
Красноярск (391)204-63-61
Курск (4712)77-13-04
Курган (3522)50-90-47
Липецк (4742)52-20-81

Магнитогорск (3519)55-03-13
Москва (495)268-04-70
Мурманск (8152)59-64-93
Набережные Челны (8552)20-53-41
Нижний Новгород (831)429-08-12
Новокузнецк (3843)20-46-81
Ноябрьск (3496)41-32-12
Новосибирск (383)227-86-73
Омск (3812)21-46-40
Орел (4862)44-53-42
Оренбург (3532)37-68-04
Пенза (8412)22-31-16
Петрозаводск (8142)55-98-37
Псков (8112)59-10-37
Пермь (342)205-81-47

Ростов-на-Дону (863)308-18-15
Рязань (4912)46-61-64
Самара (846)206-03-16
Санкт-Петербург (812)309-46-40
Саратов (845)249-38-78
Севастополь (8692)22-31-93
Ставрополь (8652)20-96-24
Симферополь (3652)67-13-56
Смоленск (4812)29-41-54
Сочи (862)225-72-31
Ставрополь (8652)20-65-13
Сургут (3462)77-98-35
Сыктывкар (8212)25-95-17
Тамбов (4752)50-40-97
Тверь (4822)63-31-35

Тольятти (8482)63-91-07
Томск (3822)98-41-53
Тула (4872)33-79-87
Тюмень (3452)66-21-18
Ульяновск (8422)24-23-59
Улан-Удэ (3012)59-97-51
Уфа (347)229-48-12
Хабаровск (4212)92-98-04
Чебоксары (8352)28-53-07
Челябинск (351)202-03-61
Череповец (8202)49-02-64
Чита (3022)38-34-83
Якутск (4112)23-90-97
Ярославль (4852)69-52-93

Россия +7(495)268-04-70

Казахстан +7(7172)727-132

Киргизия +996(312)96-26-47

эл.почта: ehr@nt-rt.ru || сайт: <https://endcounters.nt-rt.ru/>