

Электромагнитные расходомеры Proline Promag 23H

Технические характеристики

По вопросам продаж и поддержки обращайтесь:

Алматы (7273)495-231
Ангарск (3955)60-70-56
Архангельск (8182)63-90-72
Астрахань (8512)99-46-04
Барнаул (3852)73-04-60
Белгород (4722)40-23-64
Благовещенск (4162)22-76-07
Брянск (4832)59-03-52
Владивосток (423)249-28-31
Владикавказ (8672)28-90-48
Владимир (4922)49-43-18
Волгоград (844)278-03-48
Вологда (8172)26-41-59
Воронеж (473)204-51-73
Екатеринбург (343)384-55-89

Иваново (4932)77-34-06
Ижевск (3412)26-03-58
Иркутск (395)279-98-46
Казань (843)206-01-48
Калининград (4012)72-03-81
Калуга (4842)92-23-67
Кемерово (3842)65-04-62
Киров (8332)68-02-04
Коломна (4966)23-41-49
Кострома (4942)77-07-48
Краснодар (861)203-40-90
Красноярск (391)204-63-61
Курск (4712)77-13-04
Курган (3522)50-90-47
Липецк (4742)52-20-81

Магнитогорск (3519)55-03-13
Москва (495)268-04-70
Мурманск (8152)59-64-93
Набережные Челны (8552)20-53-41
Нижний Новгород (831)429-08-12
Новокузнецк (3843)20-46-81
Ноябрьск (3496)41-32-12
Новосибирск (383)227-86-73
Омск (3812)21-46-40
Орел (4862)44-53-42
Оренбург (3532)37-68-04
Пенза (8412)22-31-16
Петрозаводск (8142)55-98-37
Псков (8112)59-10-37
Пермь (342)205-81-47

Ростов-на-Дону (863)308-18-15
Рязань (4912)46-61-64
Самара (846)206-03-16
Санкт-Петербург (812)309-46-40
Саратов (845)249-38-78
Севастополь (8692)22-31-93
Саранск (8342)22-96-24
Симферополь (3652)67-13-56
Смоленск (4812)29-41-54
Сочи (862)225-72-31
Ставрополь (8652)20-65-13
Сургут (3462)77-98-35
Сыктывкар (8212)25-95-17
Тамбов (4752)50-40-97
Тверь (4822)63-31-35

Тольятти (8482)63-91-07
Томск (3822)98-41-53
Тула (4872)33-79-87
Тюмень (3452)66-21-18
Ульяновск (8422)24-23-59
Улан-Удэ (3012)59-97-51
Уфа (347)229-48-12
Хабаровск (4212)92-98-04
Чебоксары (8352)28-53-07
Челябинск (351)202-03-61
Череповец (8202)49-02-64
Чита (3022)38-34-83
Якутск (4112)23-90-97
Ярославль (4852)69-52-93

Россия +7(495)268-04-70

Казахстан +7(7172)727-132

Киргизия +996(312)96-26-47

эл.почта: ehr@nt-rt.ru || сайт: <https://endcounters.nt-rt.ru/>



Level



Pressure



Flow



Temperature



Liquid
Analysis



Registration



Systems
Components



Services



Solutions

Technical Information

Proline Promag 23H

Electromagnetic Flow Measuring System – Two-wire technology
Flow measurement of liquids in
hygienic, food or process applications



Application

Electromagnetic flowmeter for bidirectional measurement of liquids with a minimum conductivity of $\geq 50 \mu\text{S}/\text{cm}$:

- Beverages, e.g. fruit juice, beer, wine
- Dairy products, fruit mixes
- Saline solutions
- Acid, alkalis etc.
- Flow measurement up to $4700 \text{ dm}^3/\text{min}$ (1250 gal/min)
- Fluid temperature up to $+150 \text{ }^\circ\text{C}$ ($+302 \text{ }^\circ\text{F}$)
- Process pressures up to 40 bar (580 psi)
- CIP-/SIP cleaning

Approvals in food sector/hygiene sector:

- 3A approval, EHEDG-tested, conform to FDA, USP Class VI

Application-specific lining material:

- PFA

Approvals for hazardous area:

- ATEX, FM, CSA

Your benefits

Promag measuring devices offer you cost-effective flow measurement with a high degree of accuracy for a wide range of process conditions.

The uniform Proline transmitter concept comprises:

- High degree of reliability and measuring stability
- Uniform operating concept

The tried-and-tested Promag sensors offer:

- No pressure loss
- Not sensitive to vibrations
- Simple installation and commissioning
- Connection to all mainstream transmitter power supplies and input cards of process control systems
- Reduced installation and operation cost because of the two-wire technology
- "Touch Control": operation without opening the housing, also in hazardous areas

Table of contents

Function and system design	3	Mechanical construction	15
Measuring principle	3	Design, dimensions	15
Measuring system	3	Weight	30
Input	3	Measuring tube specifications	30
Measured variable	3	Material	31
Measuring ranges	3	Material load diagram	31
Operable flow range	3	Fitted electrodes	33
Output	4	Process connections	33
Output signal	4	Surface roughness	33
Signal on alarm	4	Human interface	33
Load	4	Display elements	33
Low flow cutoff	5	Operating elements	33
Galvanic isolation	5	Language groups	33
Power supply	5	Certificates and approvals	34
Electrical connection, measuring unit	5	CE mark	34
Electrical connection, terminal assignment	5	C-tick mark	34
Supply voltage (power supply)	6	Pressure measuring device approval	34
Cable entry	6	Ex approval	34
Cable specifications	6	Other standards and guidelines	34
Power supply failure	6	Sanitary compatibility	34
Potential equalization	6	Ordering information	35
Performance characteristics	7	Accessories	35
Reference operating conditions	7	Documentation	35
Maximum measured error	7	Registered trademarks	35
Repeatability	7		
Operating conditions: Installations	8		
Installation instructions	8		
Inlet and outlet run	11		
Adapters	11		
Operating conditions: Environment	12		
Ambient temperature range	12		
Storage temperature	12		
Degree of protection	12		
Shock and vibration resistance	12		
CIP cleaning	12		
SIP cleaning	12		
Electromagnetic compatibility (EMC)	12		
Operating conditions: Process	13		
Medium temperature range	13		
Conductivity	13		
Medium pressure range (nominal pressure)	13		
Pressure tightness	13		
Limiting flow	13		
Pressure loss	14		

Function and system design

Measuring principle

Following *Faraday's law of magnetic induction*, a voltage is induced in a conductor moving through a magnetic field.

In the electromagnetic measuring principle, the flowing medium is the moving conductor.

The voltage induced is proportional to the flow velocity and is supplied to the amplifier by means of two measuring electrodes. The flow volume is calculated by means of the pipe cross-sectional area.

The DC magnetic field is created through a switched direct current of alternating polarity.

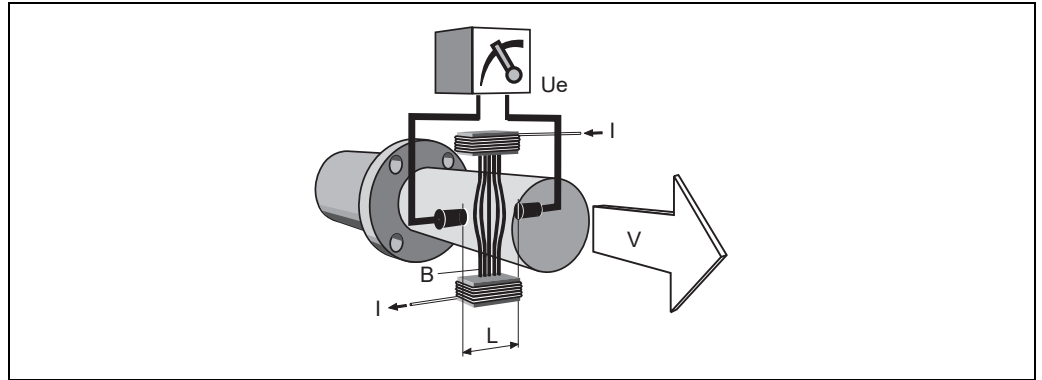

$$U_e = B \cdot L \cdot v$$

$$Q = A \cdot v$$

U_e Induced voltage

B Magnetic induction (magnetic field)

L Electrode spacing

v Flow velocity

Q Volume flow

A Pipe cross-section

I Current strength

Measuring system

The measuring system consists of a transmitter and a sensor.

Two versions are available:

- Compact version: Transmitter and sensor form a mechanical unit.

Transmitter:

- Promag 23 ("Touch Control" without opening the housing, four-line display, unilluminated)

Sensor:

- Promag H (DN 2 to 100 / 1/12 to 4")

Input

Measured variable

Flow velocity (proportional to induced voltage)

Measuring ranges

Measuring ranges for liquids

Typically $v = 0.01$ to 10 m/s (0.03 to 33 ft/s) with the specified accuracy

Operable flow range

Over 1000 : 1

Output

Output signal

Current output

Applied direct current 4 to 20 mA, input from DC voltage source.

- Terminal voltage: 12 to 30 V DC, 13.9 to 30 V DC (Ex i)
- Resolution: 4.4 μ A

Frequency output

Open Collector, passive, galvanically isolated, 30 V DC, 100 mA (250 mA / 20 ms).

Optional configurable as:

- Frequency output:
 - Full scale frequency 500 to 10000 Hz ($f_{\max} = 12,5$ kHz)
 - or
- Pulse output:
 - Pulse value and pulse polarity adjustable, pulse width adjustable (0.01 to 10 s), pulse frequency max. 50 Hz
 - or
- Status output:
 - e.g. for error messages, Empty Pipe Detection, flow direction recognition, limit value configurable

Ex i version

- Power-supply, signal circuits and pulse output with "intrinsically safe" protection rating, EEx ia IIC and EEx ia IIB, only for connection to certified, intrinsically safe circuits with the following maximum values:
 - $U_i = 30$ V, $I_i = 150$ mA, $P_i = 810$ mW
 - Effective internal inductance: negligible
 - Effective internal capacitance: $C_i \leq 25$ nF
- Pulse output:
 - Maximum values: $U_i = 30$ V, $I_i = 10$ mA, $P_i = 1$ W
 - Effective internal inductance: negligible
 - Effective internal capacitance: negligible

Signal on alarm

- Current output → Failsafe mode can be selected
- Pulse output → Failsafe mode can be selected
- Status output → "Not conductive" in the event of fault or power supply failure

Load

The load has to be calculated as follows:

- Non Ex area:
$$R_L[\Omega] = \frac{U_s[V] - U_v[V]}{I_M[A]} = \frac{U_s[V] - 12[V]}{0,022[A]}$$

- Ex area:
$$R_L[\Omega] = \frac{U_s[V] - U_v[V]}{I_M[A]} = \frac{U_s[V] - 13,9[V]}{0,022[A]}$$

$R_L[\Omega]$ = max. load resistance, load
(cable resistance)

$U_s[V]$ = external supply voltage of 12 to 30 V DC
(outgoing supply voltage, transmitter supply unit)

$U_v[V]$ = min. supply voltage of 12 V DC (13.9 V DC for Ex-i)
(required supply voltage, transmitter)

$I_M[A]$ = max. signal transmission current
(failsafe mode current output: 22 mA max. current)



Note!

The minimum load resistance (R_L) necessary for a data transfer via HART protocol by way of the current signal cable is 250 Ω . The minimum external supply voltage (U_s) therefore has to be 17.5 V DC (non Ex).

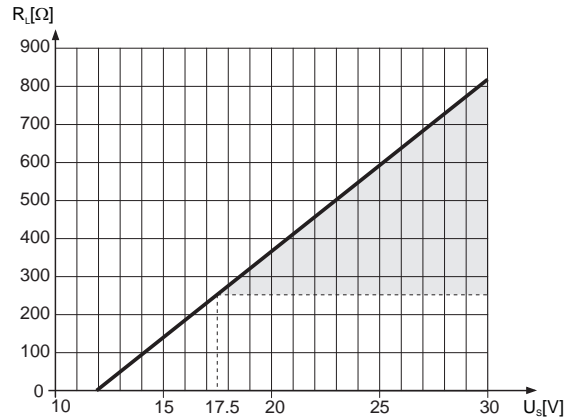

A0009613

Load at the analog current output (non Ex)

- R_L : max. load resistance (with HART: min. 250 Ω)
- U_s : external supply voltage (non Ex)

Low flow cutoff Switch-on points for low flow are selectable.

Galvanic isolation Outputs are galvanically isolated from sensor and from each other.

Power supply

Electrical connection, measuring unit

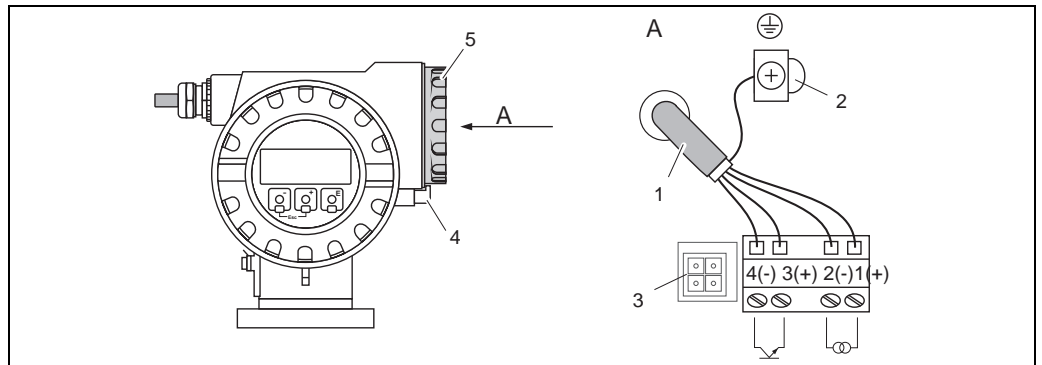

A0009604

Connecting the transmitter, cable cross-section max. 2.5 mm² (14 AWG)

- 1 Shielded signal cable (the Ex version requires the use of separate cables for transmitter supply and frequency output):
 - Terminal No. 1(+)/ 2(-): transmitter supply / current output
 - Terminal No. 3(+)/ 4(-): frequency output
- 2 Grounding terminal for signal-cable shield
- 3 Service plug
- 4 Safety claw
- 5 Connection compartment cover

Electrical connection, terminal assignment

Order version	Terminal No.			
	1 (+)	2 (-)	3 (+)	4 (-)
23***_*****W	HART current output		-	
23***_*****A	HART current output		Frequency output	

A common connecting cable carries supply voltage and measuring output signal:

- Current output (passive)
- galvanically isolated: 12 to 30 V DC (Ex i: 13.9 to 30 V DC), 4 to 20 mA

Supply voltage (power supply)	<p>Non-hazardous area:</p> <ul style="list-style-type: none"> ■ 12 to 30 V DC ■ 17.5 to 30 V DC (HART) <p>Intrinsically safe area:</p> <ul style="list-style-type: none"> ■ 13.9 to 30 V DC ■ 19.4 to 30 V DC (HART)
Cable entry	<p>Power supply and signal cables (inputs/ outputs):</p> <ul style="list-style-type: none"> ■ Cable entry M20 × 1.5 (8 to 12 mm / 0.31 to 0.47") ■ Thread for cable entries, ½" NPT, G ½"
Cable specifications	Use shielded cables.
Power supply failure	<ul style="list-style-type: none"> ■ T-DAT™ retain the measuring system data in the event of a power supply failure ■ S-DAT™: exchangeable data storage chip which stores the data of the sensor (nominal diameter, serial number, calibration factor, zero point etc.)

Potential equalization Perfect measurement is only ensured when the medium and the sensor have the same electrical potential.

Metal process connections

Potential matching usually takes place over the metallic process connection in contact with medium process connections which are directly mounted on the measuring transmitter. This usually means that additional potential matching measures are unnecessary.



Note!

For installation in metal pipes, it is advisable to connect the ground terminal of the transmitter housing to the piping.

Plastic process connections

For plastic process connections, potential matching must be ensured between sensor and medium using additional ground rings. If these ground rings are missing, this can influence accuracy or destroy the measuring transmitter through the electrochemical decomposition of electrodes.

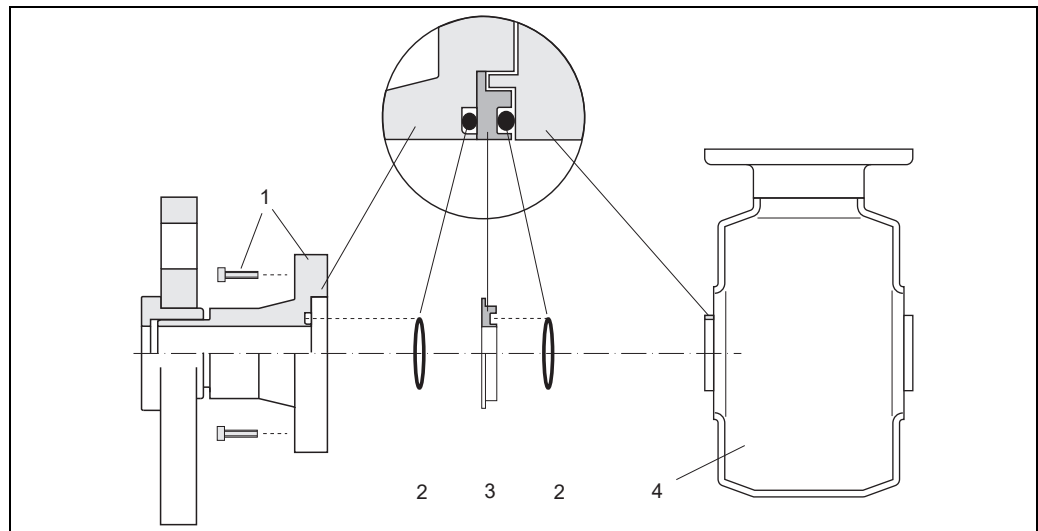

- 1 Allen screw (process connection)
- 2 O-ring seals
- 3 Plastic washer (spacer) or ground ring
- 4 Sensor

When using ground rings, note the following points:

- Depending on the option ordered, plastic washers may be installed at the process connections instead of ground rings. These plastic washers serve only as spacers and have no potential equalization function. In addition, they provide a sealing function at the interface between the sensor and process connection. For this reason, with process connections without ground rings, these plastic washers/seals must not be removed, or must always be installed.
- Ground rings, incl. seals, are mounted inside the process connection. This has no influence on the installation length. You can find the dimensions of ground rings on → 24.

Performance characteristics

Reference operating conditions

As per DIN EN 29104 and VDI/VDE 2641:

- Fluid temperature: $+28\text{ °C} \pm 2\text{ K}$
- Ambient temperature: $+22\text{ °C} \pm 2\text{ K}$
- Warm-up period: 30 minutes

Installation conditions:

- Inlet run $> 10 \times \text{DN}$
- Outlet run $> 5 \times \text{DN}$
- Sensor and transmitter grounded.
- The sensor is centered in the pipe.

Maximum measured error

- Pulse output: $\pm 0.5\%$ o.r. $\pm 4\text{ mm/s}$ (o.r. = of reading)
- Current output: also typically $\pm 5\text{ }\mu\text{A}$

Fluctuations in the supply voltage do not have any effect within the specified range.

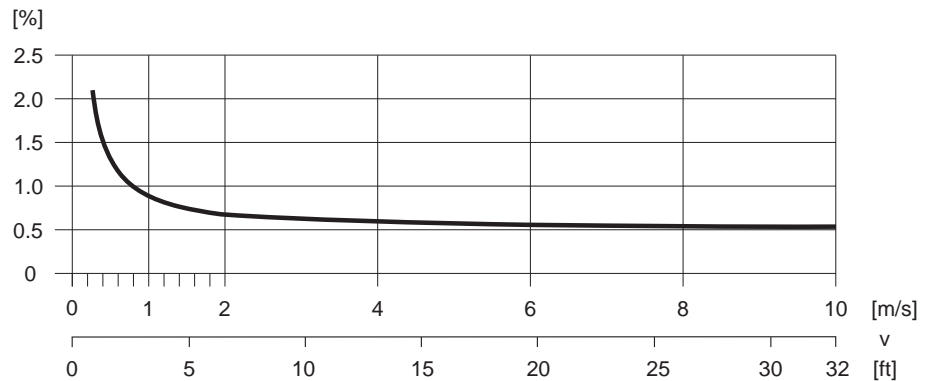

Max. measured error in % of reading

A0009612

Repeatability

Max. $\pm 0.25\%$ o.r. $\pm 2\text{ mm/s}$ (o.r. = of reading)

Operating conditions: Installations

Installation instructions

Mounting location

Entrained air or gas bubble formation in the measuring tube can result in an increase in measuring errors.

Avoid the following installation locations in the pipe:

- Highest point of a pipeline. Risk of air accumulating!
- Directly upstream from a free pipe outlet in a vertical pipeline.

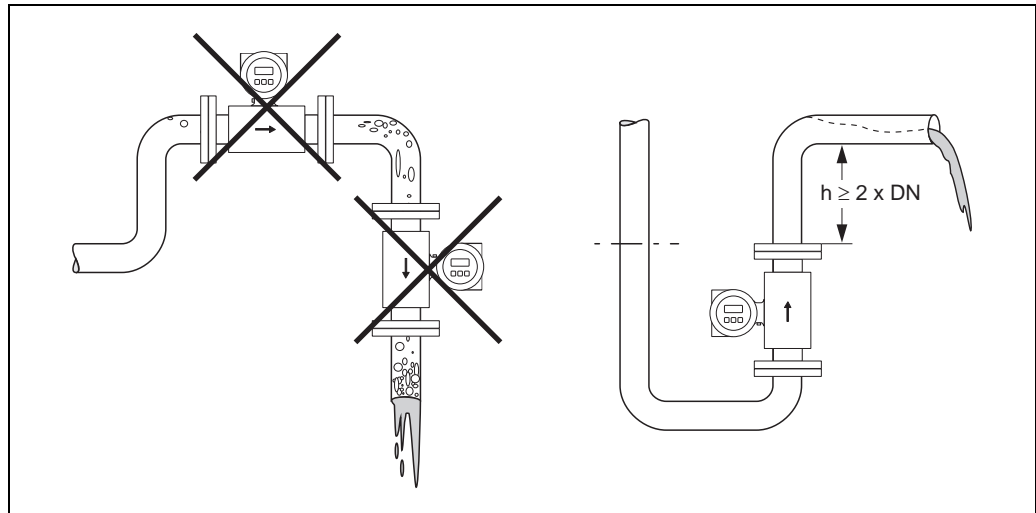

A0003202

Mounting location

Installation of pumps

Sensors may not be installed on the pump suction side. This precaution is to avoid low pressure and the consequent risk of damage to the lining of the measuring tube. Information on the pressure tightness of the measuring tube lining → 13, Section "Pressure tightness".

Pulsation dampers may be needed when using piston pumps, piston diaphragm pumps or hose pumps. Information on the shock and vibration resistance of the measuring system → 12, Section "Shock and vibration resistance".

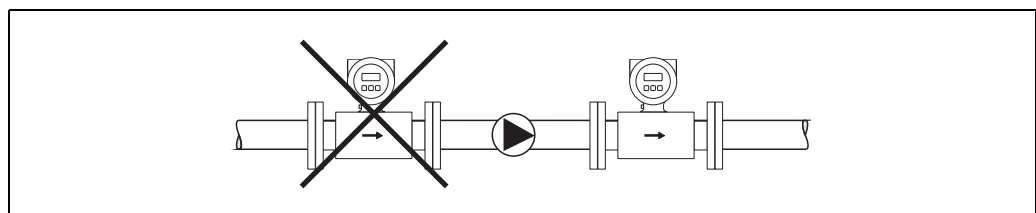

A0003203

Installation of pumps

Partially filled pipes

Partially filled pipes with gradients necessitate a drain-type configuration.

The empty pipe detection function (EPD) provides additional security in detecting empty or partially filled pipes.



Caution!

Risk of solids accumulating. Do not install the sensor at the lowest point in the drain. It is advisable to install a cleaning valve.

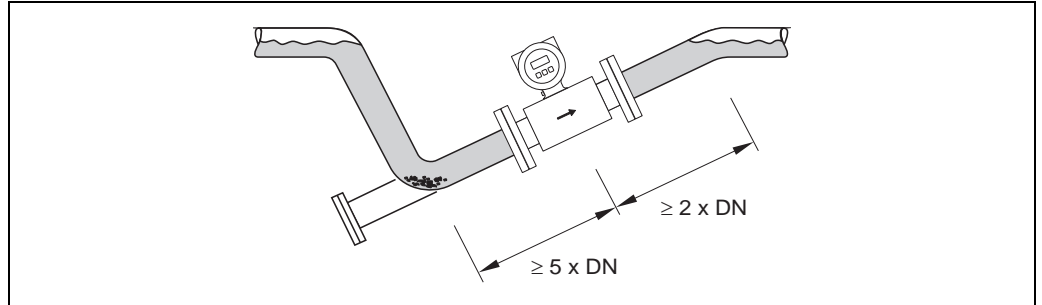

Installation with partially filled pipes

Down pipes

Install a siphon or a vent valve downstream of the sensor in down pipes $h \geq 5$ m (16.4 ft). This precaution is to avoid low pressure and the consequent risk of damage to the lining of the measuring tube. This measure also prevents the liquid current stopping in the pipe which could cause air locks. Information on the pressure tightness of the measuring tube lining → 13, Section "Pressure tightness".

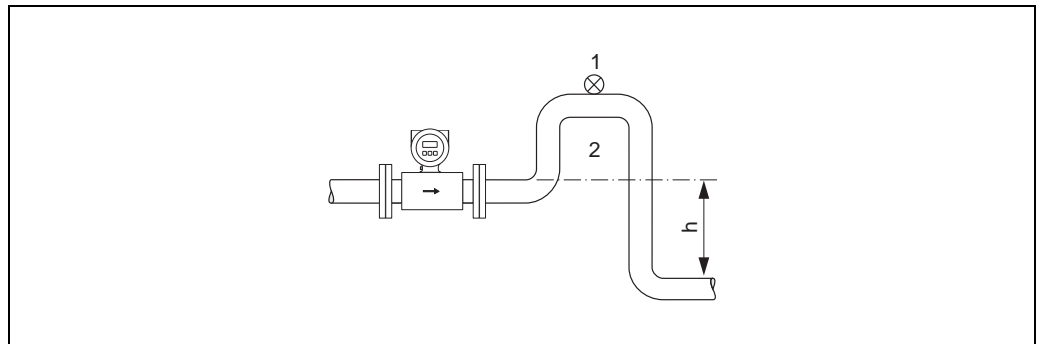

Installation measures for vertical pipes

- 1 Vent valve
- 2 Pipe siphon
- h Length of the down pipe

Orientation

An optimum orientation helps avoid gas and air accumulations and deposits in the measuring tube. However, the measuring device also offers the additional function of empty pipe detection (EPD) for detecting partially filled measuring tubes or if outgassing fluids or fluctuating operating pressures are present.

Vertical orientation

This is the ideal orientation for self-emptying piping systems and for use in conjunction with empty pipe detection.

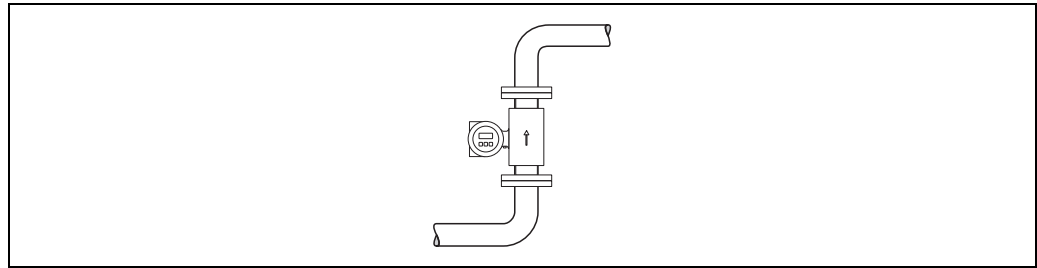

Vertical orientation

Horizontal orientation

The measuring electrode axis should be horizontal. This prevents brief insulation of the two measuring electrodes by entrained air bubbles.



Caution!

Empty pipe detection only works correctly with horizontal orientation if the transmitter housing is facing upwards. Otherwise there is no guarantee that empty pipe detection will respond if the measuring tube is only partially filled or empty.

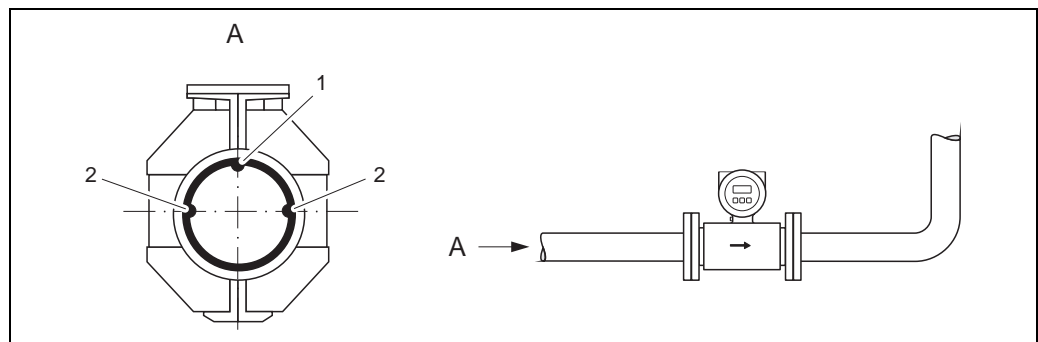

Horizontal orientation

- 1 EPD electrode for empty pipe detection (not for DN 2 to 15 / 1/12 to 1/2")
- 2 Measuring electrodes for signal detection

Vibrations

Secure the piping and the sensor if vibration is severe.



Caution!

If vibrations are too severe, we recommend the sensor and transmitter be mounted separately. Information on the permitted shock and vibration resistance → 12, Section "Shock and vibration resistance".

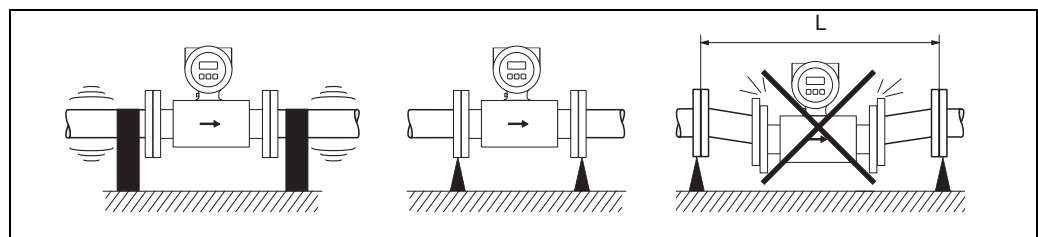

Measures to prevent vibration of the measuring device

$L > 10 \text{ m (33 ft)}$

Inlet and outlet run

If possible, install the sensor well clear of assemblies such as valves, T-pieces, elbows etc.

Note the following inlet and outlet runs to comply with measuring accuracy specifications:

- Inlet run: $\geq 5 \times \text{DN}$
- Outlet run: $\geq 2 \times \text{DN}$

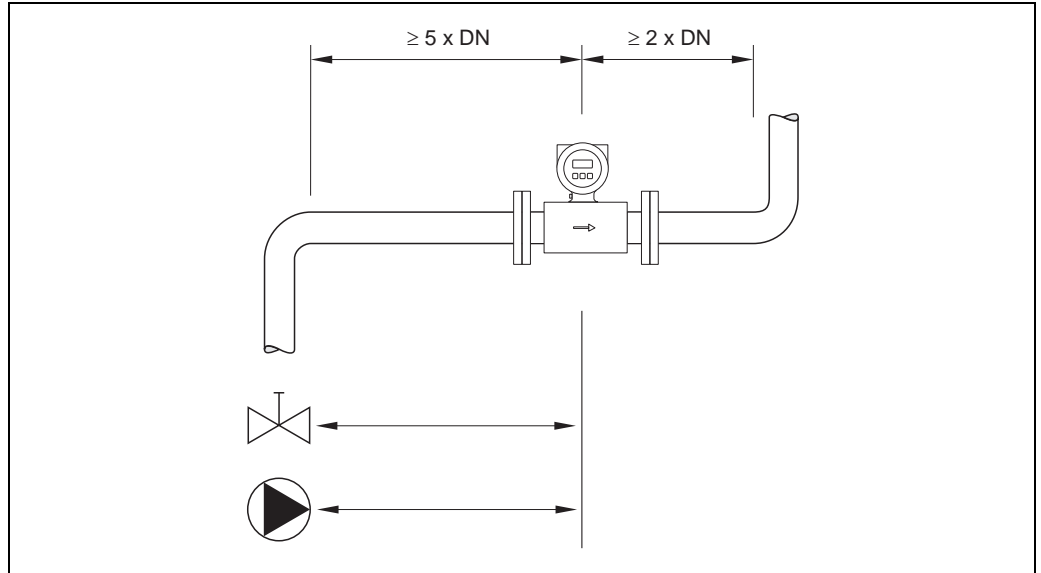

Inlet and outlet run

A0003210

Adapters

Suitable adapters to DIN EN 545 (double-flange reducers) can be used to install the sensor in larger-diameter pipes. The resultant increase in the rate of flow improves measuring accuracy with very slow-moving fluids. The nomogram shown here can be used to calculate the pressure loss caused by reducers and expanders.



Note!

The nomogram only applies to liquids of viscosity similar to water.

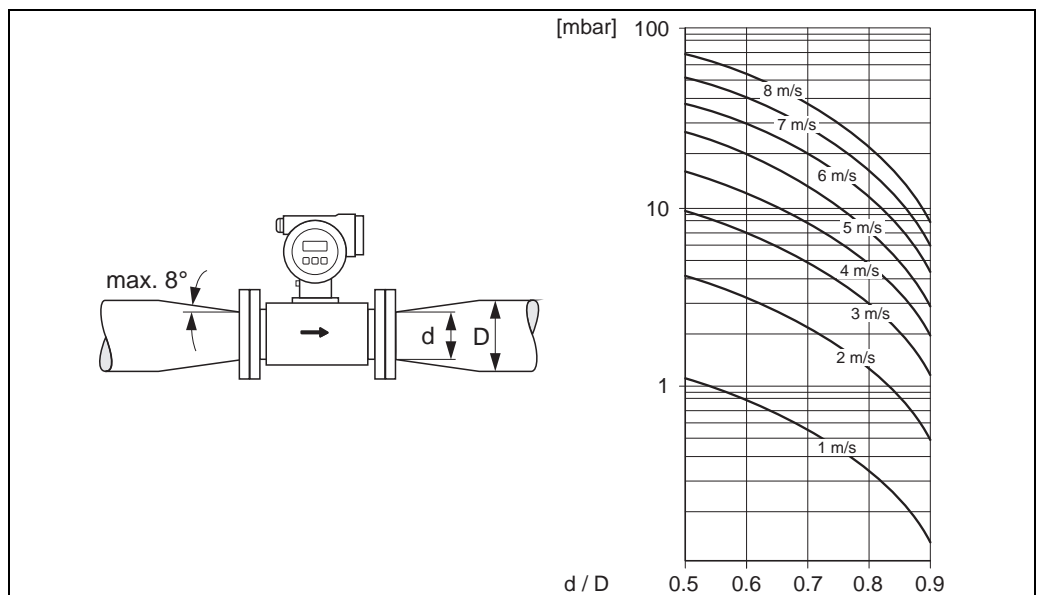

1. Calculate the ratio of the diameters d/D .
2. From the nomogram read off the pressure loss as a function of flow velocity (downstream from the reduction) and the d/D ratio.



Pressure loss due to adapters

A0009611

Operating conditions: Environment

Ambient temperature range	-20 to +60 °C (-4 to +140 °F)
	<p>Caution!</p> <p>The permitted temperature range of the measuring tube lining may not be undershot or overshot (→ 13, Section "Medium temperature range").</p> <p>Please note the following points:</p> <ul style="list-style-type: none"> ■ Install the device in a shady location. Avoid direct sunlight, particularly in warm climatic regions.
Storage temperature	-10 to +50 °C (+14 to +122 °F), preferably +20 °C (+68 °F)
	<p>Caution!</p> <ul style="list-style-type: none"> ■ The measuring device must be protected against direct sunlight during storage in order to avoid unacceptably high surface temperatures. ■ A storage location must be selected where moisture does not collect in the measuring device. This will help prevent fungus and bacteria infestation which can damage the liner. ■ If protecting caps or protective covers are mounted, these must not be removed before mounting the device.
Degree of protection	<ul style="list-style-type: none"> ■ Standard: IP 67 (NEMA 4X) for transmitter and sensor.
Shock and vibration resistance	Acceleration up to 2 g following IEC 600 68-2-6
CIP cleaning	possible
SIP cleaning	possible
Electromagnetic compatibility (EMC)	<ul style="list-style-type: none"> ■ As per IEC/EN 61326 and NAMUR recommendation NE 21 ■ Emission: to limit value for industry EN 55011

Operating conditions: Process

Medium temperature range

The permissible medium temperature depends on the sensor and the sealing material:

Sensor:

- DN 2 to 100 (1/12 to 4"): -20 to +150 °C (-4 to +302 °F)

Seals:

- EPDM: -20 to +150 °C (-4 to 302 °F)
- Silicone: -20 to +150 °C (-4 to 302 °F)
- Viton: -20 to +150 °C (-4 to 302 °F)
- Kalrez: -20 to +150 °C (-4 to 302 °F)

Conductivity

The minimum conductivity is: $\geq 50 \mu\text{S}/\text{cm}$ (for fluids in general)

Medium pressure range (nominal pressure)

The permitted nominal pressure depends on the process connection and the seal:

- 40 bar (580 psi): flange, weld socket (with O-ring seal)
- 16 bar (232 psi): all other process connections

Pressure tightness

Measuring tube lining: PFA

Nominal diameter		Limit values for abs. pressure [mbar] ([psi]) at fluid temperatures:				
[mm]	[inch]	25 °C (77 °F)	80 °C (176 °F)	100 °C (212 °F)	130 °C (266 °F)	150 °C (302 °F)
2 to 100	1/12 to 4"	0	0	0	0	0

Limiting flow

The diameter of the pipe and the flow rate determine the nominal diameter of the sensor.

The optimum flow velocity is between 2 to 3 m/s (6.5 to 9.8 ft/s). The velocity of flow (v), moreover, has to be matched to the physical properties of the fluid:

- $v < 2 \text{ m/s}$ (6.5 ft/s): for small conductivities
- $v > 2 \text{ m/s}$ (6.5 ft/s): for fluids causing build-up such as high-fat milk etc.

Flow characteristic values (SI units)						
Diameter		Recommended flow rate Min./max. full scale value ($v \sim 0.3$ or 10 m/s)	Factory settings			
[mm]	[inch]		Full scale value, current output ($v \sim 2.5 \text{ m/s}$)	Pulse value ($\sim 2 \text{ pulses/s}$)	Low flow cut off ($v \sim 0.04 \text{ m/s}$)	
2	1/12"	0.06 to 1.8 dm ³ /min	0.5 dm ³ /min	0.005 dm ³	0.01 dm ³ /min	
4	1/8"	0.25 to 7 dm ³ /min	2 dm ³ /min	0.025 dm ³	0.05 dm ³ /min	
8	3/8"	1 to 30 dm ³ /min	8 dm ³ /min	0.10 dm ³	0.1 dm ³ /min	
15	1/2"	4 to 100 dm ³ /min	25 dm ³ /min	0.20 dm ³	0.5 dm ³ /min	
25	1"	9 to 300 dm ³ /min	75 dm ³ /min	0.50 dm ³	1.00 dm ³ /min	
40	1 1/2"	25 to 700 dm ³ /min	200 dm ³ /min	1.50 dm ³	3.00 dm ³ /min	
50	2"	35 to 1100 dm ³ /min	300 dm ³ /min	2.50 dm ³	5.00 dm ³ /min	
65	–	60 to 2000 dm ³ /min	500 dm ³ /min	5.00 dm ³	8.00 dm ³ /min	
80	3"	90 to 3000 dm ³ /min	750 dm ³ /min	5.00 dm ³	12.0 dm ³ /min	
100	4"	145 to 4700 dm ³ /min	1200 dm ³ /min	10.0 dm ³	20.0 dm ³ /min	

Flow characteristic values (US units)					
Diameter		Recommended flow rate Min./max. full scale value (v ~ 0.3 or 10 m/s)	Factory settings		
[inch]	[mm]		Full scale value, current output (v ~ 2.5 m/s)	Pulse value (~ 2 pulses/s)	Low flow cut off (v ~ 0.04 m/s)
1/12"	2	0.015 to 0.5 gal/min	0.1 gal/min	0.001 gal	0.002 gal/min
1/8"	4	0.07 to 2 gal/min	0.5 gal/min	0.005 gal	0.008 gal/min
3/8"	8	0.25 to 8 gal/min	2 gal/min	0.02 gal	0.025 gal/min
1/2"	15	1.0 to 27 gal/min	6 gal/min	0.05 gal	0.10 gal/min
1"	25	2.5 to 80 gal/min	18 gal/min	0.20 gal	0.25 gal/min
1 1/2"	40	7 to 190 gal/min	50 gal/min	0.50 gal	0.75 gal/min
2"	50	10 to 300 gal/min	75 gal/min	0.50 gal	1.25 gal/min
3"	80	24 to 800 gal/min	200 gal/min	2.00 gal	2.50 gal/min
4"	100	40 to 1250 gal/min	300 gal/min	2.00 gal	4.00 gal/min

Pressure loss

- With DN 8 to 100 (3/8 to 4") no pressure loss if the sensor is installed in a pipe with the same nominal diameter.
- Pressure losses for configurations incorporating adapters according to DIN EN 545 (→  11, Section "Adapters").

Mechanical construction

Design, dimensions

Compact version DN 2 to 25 (1/12 to 1")

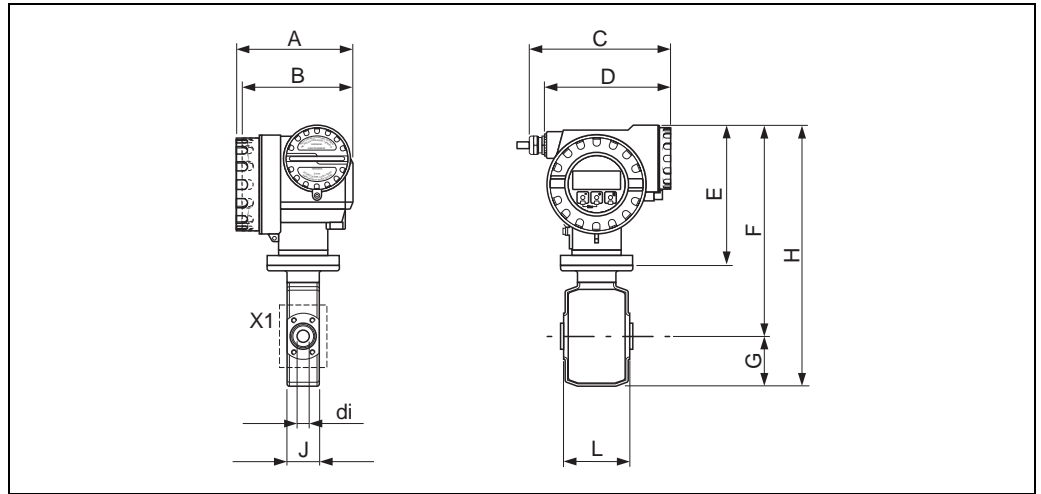

A0009627

Dimensions in SI units

DN	L	A	B	C	D	E	F	G	H	J	K	di
2	86	150	143	180	157	181	273	55	328	43	M6 × 4	2.25
4										43		4.5
8										43		9.0
15										43		16.0
25										53		26.0

Total length depends on the process connections.
All dimensions in [mm]

Dimensions in US units

DN	L	A	B	C	D	E	F	G	H	J	X1	di
1/12"	3.39	5.91	5.63	7.09	6.18	7.13	10.8	2.17	12.9	1.69	M6 × 4	0.09
1/8"										1.69		0.18
3/8"										1.69		0.35
1/2"										1.69		0.63
1"										2.20		0.89

Total length depends on the process connections.
All dimensions in [inch]

Sensor, front view (without process connections) DN 2 to 25 (1/12 to 1")

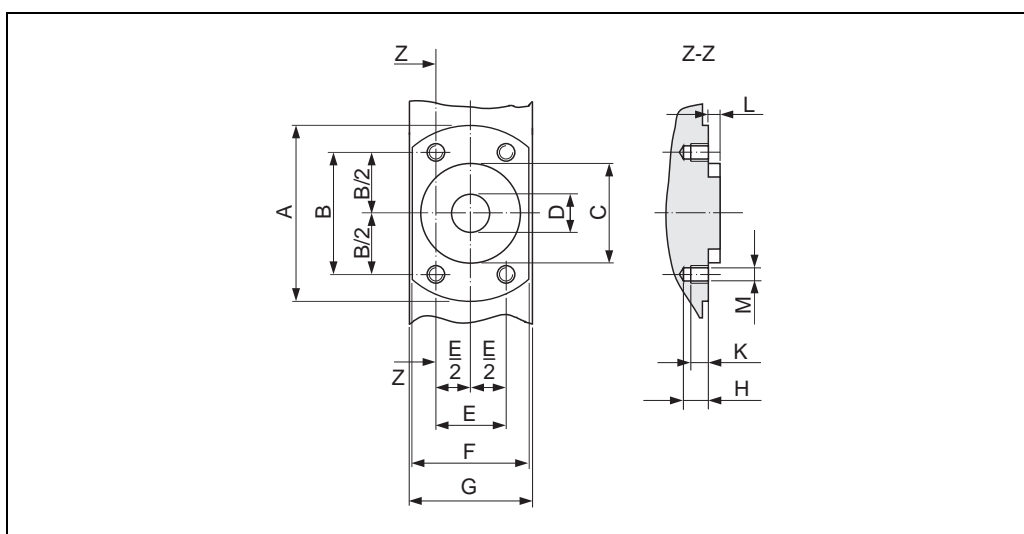

A0008190

Dimensions in SI units

DN	A	B	C	D	E	F	G	H	K	L	M
2	62	41.6	34	9	24	42	43	8.5	6	4	M6
4				9							
8				9							
15				16							
25	72	50.2	44	26	29	55	56				

All dimensions in [mm]

Dimensions in US units

DN	A	B	C	D	E	F	G	H	K	L	M
1/12"	2.44	1.64	1.34	0.35	0.94	1.65	1.69	0.33	0.24	0.16	M6
1/8"				0.35							
3/8"				0.35							
1/2"				0.63							
1"	2.83	1.98	1.73	0.89	1.14	2.17	2.20				

All dimensions in [inch]

Sensor, wall mounting kit DN 2 to 25 (1/12 to 1")

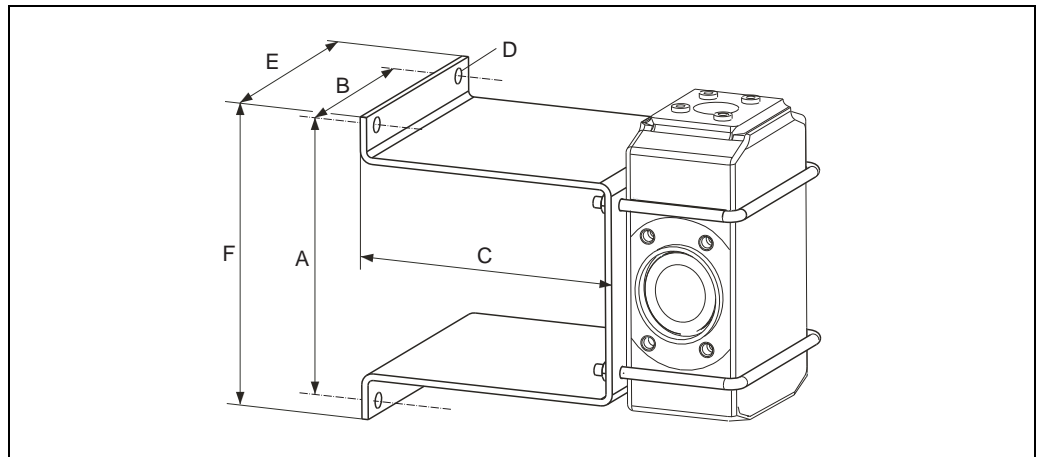

A0005537

Dimensions in mm (inch)

A	B	C	Ø D	E	F
125 (4.92")	88 (3.46")	120 (4.72")	7 (0.28")	110 (4.33")	140 (5.51")

Process connections with O-ring seal (DN 2 to 25 / 1/12 to 1")

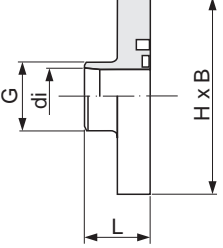
Weld socket for DIN	Sensor	Fits to	di	G	L	H x B
1.4404 / 316L 2*H**-B*****	DN [mm]	Piping DIN EN ISO 1127	[mm]	[mm]	[mm]	[mm]
	2 to 8	13.5 x 1.6	10.3	13.5	20.3	62 x 42
	15	21.3 x 1.6	18.1	21.3	20.3	62 x 42
	25 (DIN)	33.7 x 2.0	29.7	33.7	20.3	62 x 52
	<ul style="list-style-type: none"> Fitting length = (2 x L) + 86 mm 					

A0005547

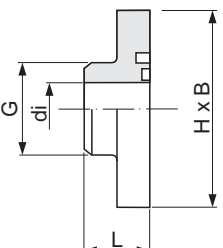
Weld socket for ODT/SMS	Sensor	Fits to	di	G	L	H x B
1.4404 / 316L 2*H**-C*****	DN [mm]	Piping ODT/SMS [mm]	[mm]	[mm]	[mm]	[mm]
	2 to 8	13.5 x 2.3	17.3	13.5	20.3	62 x 42
	15	21.3 x 2.65	17.3	21.3	20.3	62 x 42
	25 (DIN)	33.7 x 3.25	28.5	33.7	20.3	72 x 55
	<ul style="list-style-type: none"> Fitting length = (2 x L) + 86 mm 					

A0005548

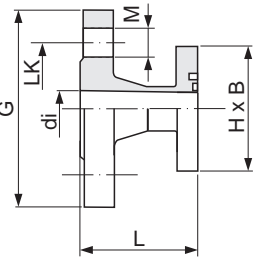
Flange	Sensor	Fits to	di	G	L	LK	M	H x B
PN 40/EN 1092-1 (DIN 2501), Form B 1.4404 / 316L 2*H**-D*****	DN [mm]	Flange ¹⁾ [mm]	[mm]	[mm]	[mm]	[mm]	[mm]	[mm]
	2 to 8	DN 15	17.3	95	56.2	65	14	62 x 42
	15	DN 15	17.3	95	56.2	65	14	62 x 42
	25 (DIN)	DN 25	28.5	115	56.2	85	14	72 x 55
	¹⁾ EN 1092-1 (DIN 2501) <ul style="list-style-type: none"> Fitting length = (2 x L) + 86 mm Fitting length to DVGW (200 mm) 							

A0005549

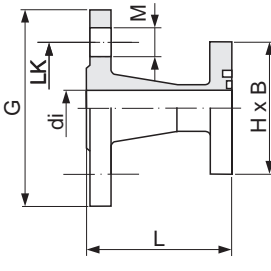
Flange	Sensor	Fits to	di	G	L	LK	M	H x B
Cl. 150/ANSI B16.5 1.4404 / 316L 2*H**-E*****	DN [mm]	Flange ANSI B16.5 [inch]	[mm]	[mm]	[mm]	[mm]	[mm]	[mm]
	2 to 8	1/2"	15.7	89	66.0	60.5	15.7	62 x 42
	15	1/2"	16.0	89	66.0	60.5	15.7	62 x 42
	25 (1" ANSI)	1"	26.7	108	71.8	79.2	15.7	72 x 55
	<ul style="list-style-type: none"> Fitting length = (2 x L) + 86 mm 							

A0005550

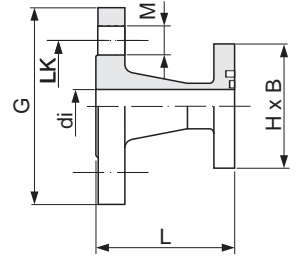
Flange	Sensor	Fits to	di	G	L	LK	M	H x B
20K / JIS B2220; 1.4404 / 316L 2*H**-F*****	DN [mm]	Flange B2220	[mm]	[mm]	[mm]	[mm]	[mm]	[mm]
	2 to 8	ND 15	15	95	67	70	15	62 x 42
	15	ND 15	16	95	67	70	15	62 x 42
	25 (DIN)	ND 25	26	125	67	90	19	72 x 55
<ul style="list-style-type: none"> Fitting length = (2 x L) + 86 mm 								

A000551

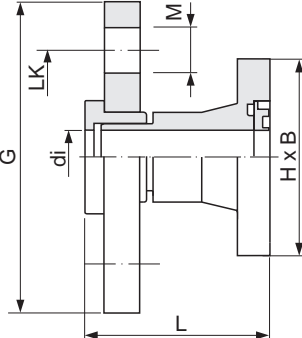
Flange	Sensor	Fits to	di	G	L	LK	M	H x B
PN 16 / EN 1092-1 (DIN 2501); PVDF 2*H**-G*****	DN [mm]	Flange EN 1092-1 (DIN 2501)	[mm]	[mm]	[mm]	[mm]	[mm]	[mm]
	2 to 8	DN 15	16	95	57	65	14	62 x 42
	15	DN 15	16	95	57	65	14	62 x 42
	25 (DIN)	DN 25	27.2	115	57	85	14	72 x 55
<ul style="list-style-type: none"> Fitting length = (2 x L) + 86 mm Fitting length to DVGW (200 mm) The requisite ground rings can be ordered as accessories (Order No. DK5HR-****). 								

A000567

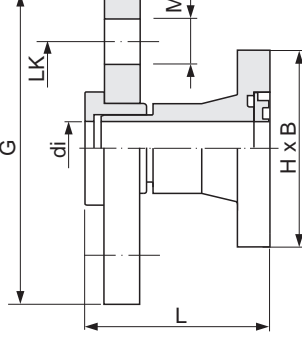
Flange	Sensor	Fits to	di	G	L	LK	M	H x B
Cl. 150 / ANSI B16.5; PVDF 2*H**-H*****	DN [mm]	Flange ANSI B16.5	[mm]	[mm]	[mm]	[mm]	[mm]	[mm]
	2 to 8	1/2"	16	95	57	60	16	62 x 42
	15	1/2"	16	95	57	60	16	62 x 42
	25 (DIN)	1"	27.2	115	57	79	16	72 x 55
<ul style="list-style-type: none"> Fitting length = (2 x L) + 86 mm The requisite ground rings can be ordered as accessories (Order No. DK5HR-****). 								

A000567

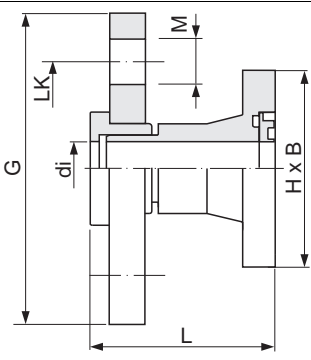
Flange	Sensor	Fits to	di	G	L	LK	M	H × B
10K / JIS B2220; PVDF 2*H**J*****	DN [mm]	Flange B2220	[mm]	[mm]	[mm]	[mm]	[mm]	[mm]
 <p>A0005567</p>	2 to 8	ND 15	15.7	95	57	70	15	62 × 42
	15	ND 15	15.7	95	57	70	15	62 × 42
	25 (DIN)	ND 25	27.3	125	57	90	19	72 × 55
<ul style="list-style-type: none"> ■ Fitting length = (2 × L) + 86 mm ■ The requisite ground rings can be ordered as accessories (Order No. DK5HR-****). 								

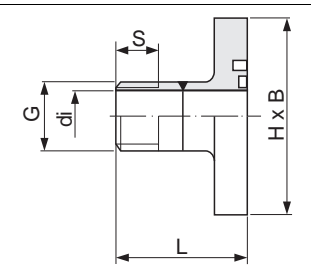
External pipe thread	Sensor	Fits to	di	G	L	S	H × B	
ISO 228/ DIN 2999; 1.4404 / 316L 2*H**K*****	DN [mm]	Internal thread [inch]	[mm]	[inch]	[mm]	[mm]	[mm]	
 <p>A0005563</p>	2 to 8	R 3/8"	10	3/8"	40	10.1	62 × 42	
	15	R 1/2"	16	1/2"	40	13.2	62 × 42	
	25 (1" ANSI)	R 1"	25	1"	42	16.5	72 × 55	
<ul style="list-style-type: none"> ■ Fitting length = (2 × L) + 86 mm 								

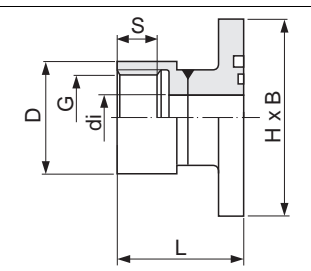
Internal pipe thread	Sensor	Fits to	di	G	D	L	S	H × B
ISO 228/ DIN 2999; 1.4404 / 316L 2*H**L*****	DN [mm]	External thread [inch]	[mm]	[inch]	[mm]	[mm]	[mm]	[mm]
 <p>A0005565</p>	2 to 8	Rp 3/8"	9	3/8"	22	45	13	62 × 42
	15	Rp 1/2"	16	1/2"	27	45	14	62 × 42
	25 (1" ANSI)	Rp 1"	27.2	1"	40	51	17	72 × 55
<ul style="list-style-type: none"> ■ Fitting length = (2 × L) + 86 mm 								

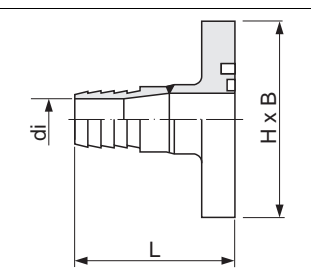
Hose connection	Sensor	Fits to	di	LW	L	H × B
1.4404 / 316L 2*H**M/N/P*****	DN [mm]	Inside diameter [inch]	[mm]	[mm]	[mm]	[mm]
 <p>A0005562</p>	2 to 8	13	10.0	13	49	62 × 42
	15	16	12.6	16	49	62 × 42
	25	19	16.0	19	49	62 × 42
<ul style="list-style-type: none"> ■ Fitting length = (2 × L) + 86 mm 						

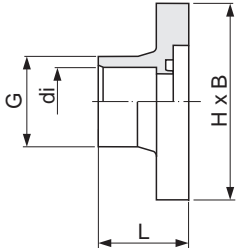
Adhesive fitting	Sensor	Fits to	di	G	L	H × B
PVC 2*H**-R/S*****	DN [mm]	Pipe [mm] [inch]	[mm]	[mm]	[mm]	[mm]
	2 to 8	½" [inch]	21.5	27.3	38.5	62 × 42
	2 to 8	20 × 2 [mm] (DIN 8062)	20.2	27.0	38.5	62 × 42
	15	20 × 2 [mm] (DIN 8062)	20.2	27.0	28.0	62 × 42
<ul style="list-style-type: none"> ■ Fitting length = (2 × L) + 86 mm ■ The requisite ground rings can be ordered as accessories (Order No. DK5HR-****). 						

Process connections with aseptic gasket seal (DN 2 to 25 / 1/12 to 1")

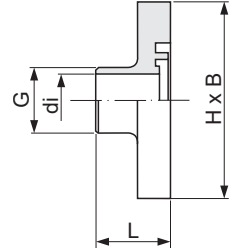
Weld socket for DIN	Sensor	Fits to	di	G	L	H × B
1.4404 / 316L 2*H**-U*****	DN [mm]	Piping DIN 11850	[mm]	[mm]	[mm]	[mm]
	2 to 8	14 × 2	9	14	23.3	62 × 42
	15	20 × 2	16	20	23.3	62 × 42
	25 (DIN)	30 × 2	26	30	23.3	72 × 55
<ul style="list-style-type: none"> ■ Fitting length = (2 × L) + 86 mm ■ If pigs are used for cleaning, it is essential to take the inside diameters of measuring tube and process connection (di) into account! 						

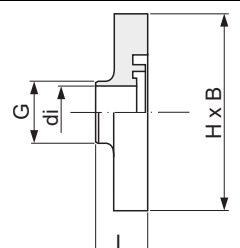
Weld socket for ODT/SMS	Sensor	Fits to	di	G	L	H × B
1.4404 / 316L 2*H**-V*****	DN [mm]	Piping ODT/SMS	[mm]	[mm]	[mm]	[mm]
	2 to 8	12.7 × 1.65	9.0	12.7	16.1	62 × 42
	15	19.1 × 1.65	16.0	19.1	16.1	62 × 42
	25 (1" ANSI)	25.4 × 1.65	22.6	25.4	16.1	72 × 55
<ul style="list-style-type: none"> ■ Fitting length = (2 × L) + 86 mm ■ If pigs are used for cleaning, it is essential to take the inside diameters of measuring tube and process connection (di) into account! 						

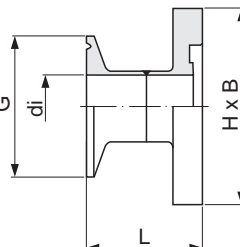
Clamp ISO 2852, Fig. 2	Sensor	Fits to piping	Clamp ISO 2850	di	G	L	H × B
1.4404 / 316L 2*H**-W*****	DN [mm]	ISO 2037 / BS 4825-1	Diameter [mm]	[mm]	[mm]	[mm]	[mm]
	25 (1" ANSI)	Tube 24.5 × 1.65	25	22.6	50.5	44.3	72 × 55
	<ul style="list-style-type: none"> ■ Fitting length = (2 × L) + 86 mm ■ If pigs are used for cleaning, it is essential to take the inside diameters of measuring tube and process connection (di) into account! 						

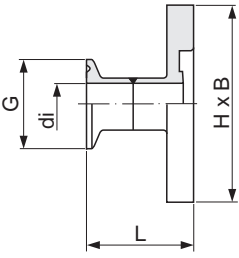
Clamp DIN 32676	Sensor	Fits to	di	G	L	H x B
1.4404 / 316L 2*H**-0*****	DN [mm]	Piping DIN 11850	[mm]	[mm]	[mm]	[mm]
	2 to 8	Tube 14 x 2 (DN 10)	10	34.0	41.0	62 x 42
	15	Tube 20 x 2 (DN 15)	16	34.0	41.0	62 x 42
	25 (DIN)	Tube 30 x 2 (DN 25)	26	50.5	44.5	72 x 55
<ul style="list-style-type: none"> ■ Fitting length = (2 x L) + 86 mm ■ If pigs are used for cleaning, it is essential to take the inside diameters of measuring tube and process connection (di) into account! 						

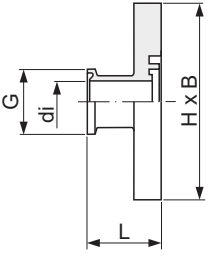
Tri-Clamp for L14 AM7	Sensor	Fits to	di	G	L	H x B
1.4404 / 316L 2*H**-1*****	DN [mm]	Piping OD	[mm]	[mm]	[mm]	[mm]
	2 to 8	Tube 12.7 x 1.65 (OD 1/2")	9.4	25.0	28.5	62 x 42
	15	Tube 19.1 x 1.65 (ODT 3/4")	15.8	25.0	28.5	62 x 42
	25 (1" ANSI)	Tube 25.4 x 1.65 (ODT 1")	22.1	50.4	28.5	72 x 55
<ul style="list-style-type: none"> ■ Fitting length = (2 x L) + 86 mm ■ If pigs are used for cleaning, it is essential to take the inside diameters of measuring tube and process connection (di) into account! 						

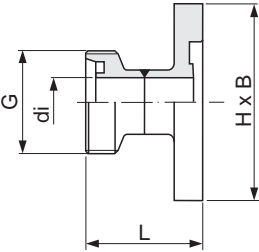
Coupling SC DIN 11851	Sensor	Fits to	di	G	L	H x B
Threaded adapter; 1.4404 / 316L 2*H**-2*****	DN [mm]	Piping DIN 11850	[mm]	[mm]	[mm]	[mm]
	2 to 8	Tube 12 x 1 (DN 10)	10	Rd 28 x 1/8"	44	62 x 42
	15	Tube 18 x 1.5 (DN 15)	16	Rd 34 x 1/8"	44	62 x 42
	25 (DIN)	Tube 28 x 1 or 28 x 1.5 (DN 25)	26	Rd 52 x 1/6"	52	72 x 55
<ul style="list-style-type: none"> ■ Fitting length = (2 x L) + 86 mm ■ If pigs are used for cleaning, it is essential to take the inside diameters of measuring tube and process connection (di) into account! 						

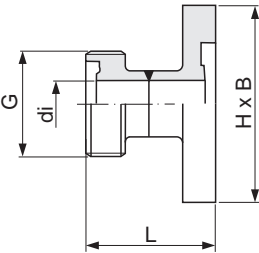
Coupling DIN 11864-1	Sensor	Fits to	di	G	L	H x B
Aseptic threaded adapter, Form A 1.4404 / 316L 2*H**-3*****	DN [mm]	Piping DIN 11850	[mm]	[mm]	[mm]	[mm]
	2 to 8	Tube 13 x 1.5 (DN 10)	10	Rd 28 x 1/8"	42	62 x 42
	15	Tube 19 x 1.5 (DN 15)	16	Rd 34 x 1/8"	42	62 x 42
	25 (DIN)	Tube 29 x 1.5 (DN 25)	26	Rd 52 x 1/6"	49	72 x 55
<ul style="list-style-type: none"> ■ Fitting length = (2 x L) + 86 mm ■ If pigs are used for cleaning, it is essential to take the inside diameters of measuring tube and process connection (di) into account! 						

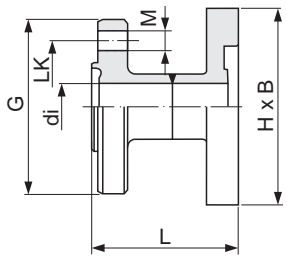
Flange DIN 11864-2	Sensor	Fits to	di	G	L	LK	M	H x B
Aseptic grooved flange, Form A 1.4404 / 316L 2*H**-4*****	DN [mm]	Piping DIN 11850	[mm]	[mm]	[mm]	[mm]	[mm]	[mm]
	2 to 8	Tube 13 x 1.5 (DN 10)	10	54	48.5	37	9	62 x 42
	15	Tube 19 x 1.5 (DN 15)	16	59	48.5	42	9	62 x 42
	25 (DIN)	Tube 29 x 1.5 (DN 25)	26	70	48.5	53	9	72 x 55
<ul style="list-style-type: none"> Fitting length = (2 x L) + 86 mm If pigs are used for cleaning, it is essential to take the inside diameters of measuring tube and process connection (di) into account! 								

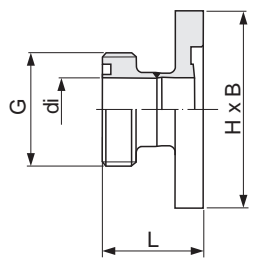
Coupling SMS 1145	Sensor	Fits to	SMS 1145	di	G	L	H x B
Threaded adapter; 1.4404 / 316L 2*H**-5*****	DN [mm]	Piping OD	Diameter [mm]	[mm]	[mm]	[mm]	[mm]
	25 (1" ANSI)	1"	25	22.6	Rd 40 x 1/6"	30.8	72 x 55
	<ul style="list-style-type: none"> Fitting length = (2 x L) + 86 mm If pigs are used for cleaning, it is essential to take the inside diameters of measuring tube and process connection (di) into account! 						

Process connections orderable only as accessories with O-ring seal (DN 2 to 25 / 1/12 to 1")

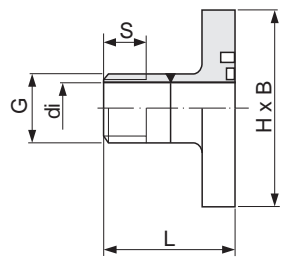
External pipe thread	Sensor	Fits to	di	G	L	S	H x B
1.4404 / 316L DKH**-GD**	DN [mm]	NP internal thread	[mm]	[inch]	[mm]	[mm]	[mm]
	2 to 8	NPT 3/8"	10	3/8"	50	15.5	62 x 42
	15	NPT 1/2"	16	1/2"	50	20.0	62 x 42
	25 (1" ANSI)	NPT 1"	25	1"	55	25.0	72 x 55
<ul style="list-style-type: none"> Fitting length = (2 x L) + 86 mm 							

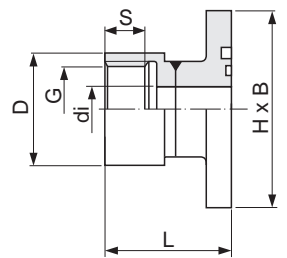
Internal pipe thread	Sensor	Fits to	di	G	D	L	S	H x B
1.4404 / 316L DKH**-GC**	DN [mm]	NP external thread	[mm]	[inch]	[mm]	[mm]	[mm]	[mm]
	2 to 8	NPT 3/8"	8.9	3/8"	22	45	13	62 x 42
	15	NPT 1/2"	16.0	1/2"	27	45	14	62 x 42
	25 (1" ANSI)	NPT 1"	27.2	1"	40	51	17	72 x 55
<ul style="list-style-type: none"> Fitting length = (2 x L) + 86 mm 								

Process connections orderable only as accessories with aseptic gasket seal (DN 15)

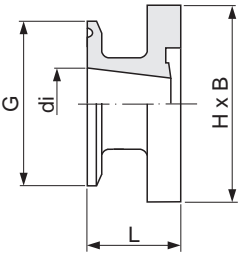
Tri-Clamp L14 AM17	Sensor	Fits to	di	G	L	H × B
1.4404 / 316L DKH**-HF**	DN [mm]	Piping OD	[mm]	[mm]	[mm]	[mm]
 <p style="text-align: right; font-size: small;">A0005555</p>	15	Tube 25.4 × 1.65 (ODT 1")	22.1	50.4	28.5	62 × 42
	<ul style="list-style-type: none"> ■ Fitting length = (2 × L) + 86 mm ■ If pigs are used for cleaning, it is essential to take the inside diameters of measuring tube and process connection (di) into account! 					

Ground rings (accessories for PVDF flanges / PVC adhesive fitting) (DN 2 to 25 / 1/12 to 1")

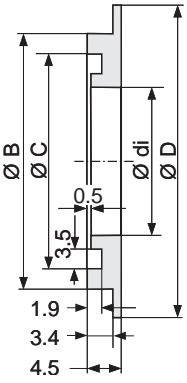
Ground ring	Sensor	di	B	C	D
1.4404 / 316L, Alloy C-22, Tantalum DK5HR - ****	DN [mm]	[mm]	[mm]	[mm]	[mm]
 <p style="text-align: right; font-size: small;">A0005568</p>	2 to 8	9.0	22.0	17.6	33.9
	15	16.0	29.0	24.6	33.9
	25 (1" ANSI)	22.6	36.5	31.2	43.9
	25 (DIN)	26.0	39.0	34.6	43.9

Compact version DN 40 to 100 (1½ to 4")

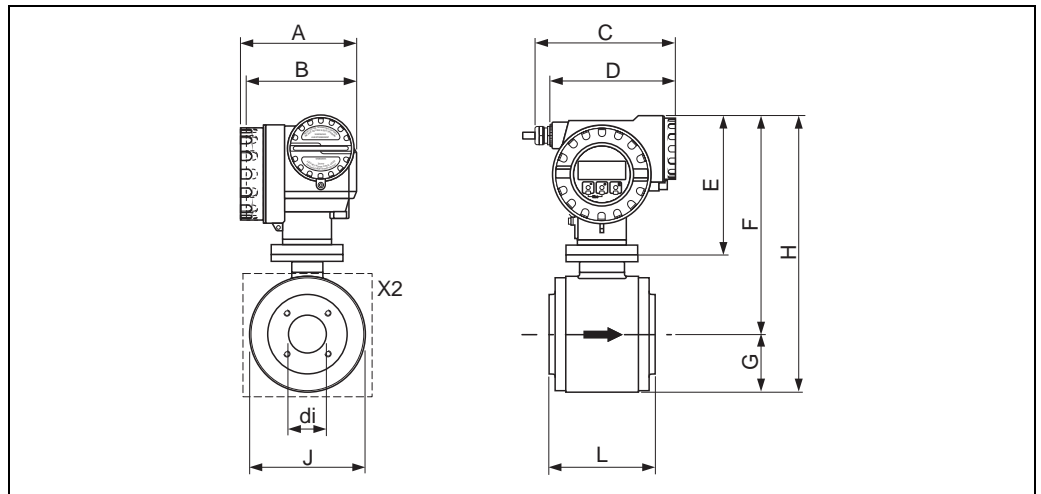

Dimensions in SI units

DN	L	A	B	C	D	E	F	G	H	J	X2	di
40	140	151	144	180	161	181	276	64	340	128	M8 × 4	35.3
50	140						288	77	365	153	M8 × 4	48.1
65	140						288	77	365	153	M8 × 6	59.9
80	200						313	102	415	203	M12 × 4	72.6
100	200						313	102	415	203	M12 × 6	97.5

Total length depends on the process connections.
All dimensions in [mm]

Dimensions in US units

DN	L	A	B	C	D	E	F	G	H	J	X2	di
1½"	5.51	5.94	5.67	7.09	6.34	7.13	10.9	2.52	13.4	5.04	M8 × 4	1.39
2"	5.51						11.3	3.03	14.4	6.02	M8 × 4	1.89
3"	7.87						12.3	4.02	16.3	7.99	M12 × 4	2.86
4"	7.87						12.3	4.02	16.3	7.99	M12 × 6	3.84

Total length depends on the process connections.
All dimensions in [inch]

Sensor, front view (without process connections) DN 40 to 100 (1½ to 4")

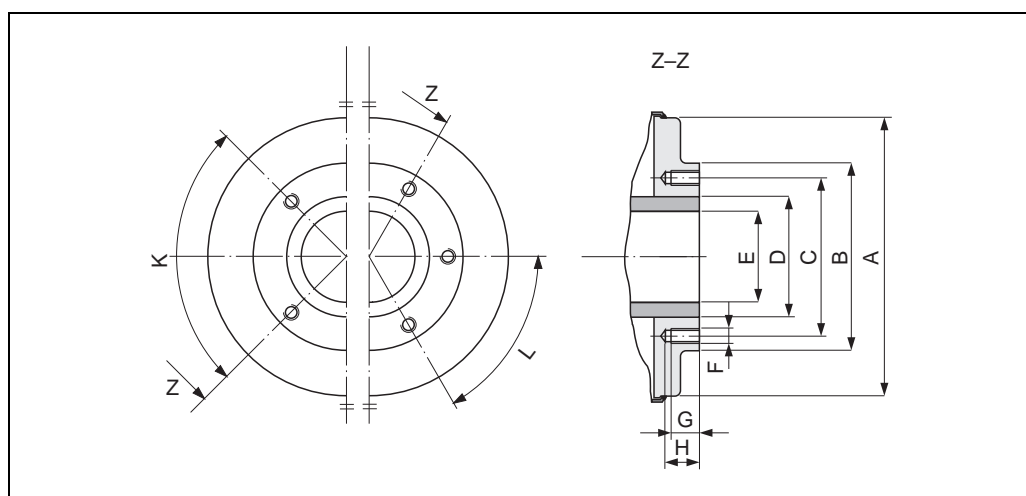

A0005528

Dimensions in SI units

DN	A	B	C	D	E	F	G	H	K	L
									90° ±0.5°	60° ±0.5°
Threaded holes										
40	122	86	71.0	51.0	35.3	M 8	15	18	4	–
50	147	99	83.5	63.5	48.1	M 8	15	18	4	–
65	147	115	100.0	76.1	59.9	M 8	15	18	–	6
80	197	141	121.0	88.9	72.6	M 12	15	20	4	–
100	197	162	141.5	114.3	97.5	M 12	15	20	–	6

All dimensions in [mm]

Dimensions in US units

DN	A	B	C	D	E	F	G	H	K	L
									90° ±0.5°	60° ±0.5°
Threaded holes										
1½"	4.80	3.39	2.80	2.01	1.39	M 8	0.59	0.71	4	–
2"	5.79	3.90	3.29	2.50	1.89	M 8	0.59	0.71	4	–
3"	7.76	5.55	4.76	3.50	2.86	M 12	0.59	0.79	4	–
4"	7.76	6.38	5.57	4.50	3.84	M 12	0.59	0.79	–	6

All dimensions in [inch]

Process connections with aseptic gasket seal DN 40 to 100 (1½ to 4")

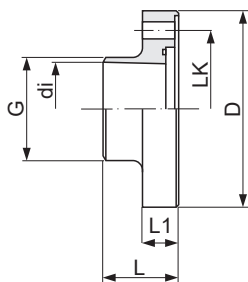
Weld socket for DIN	Sensor	Fits to	di	G	D	L	L1	LK
1.4404 / 316L 2*H**-U*****	DN [mm]	Piping DIN 11850	[mm]	[mm]	[mm]	[mm]	[mm]	[mm]
	40	42 × 2	38.0	43	92	42	19	71.0
	50	54 × 2	50.0	55	105	42	19	83.5
	65	70 × 2	66.0	72	121	42	21	100.0
	80	85 × 2	81.0	87	147	42	24	121.0
	100	104 × 2	100.0	106	168	42	24	141.5
<ul style="list-style-type: none"> - Fitting length for DN 40 to 65 = (2 × L) + 136 mm - Fitting length for DN 80 to 100 = (2 × L) + 196 mm - If pigs are used for cleaning, it is essential to take the inside diameters of measuring tube and process connection (di) into account! 								

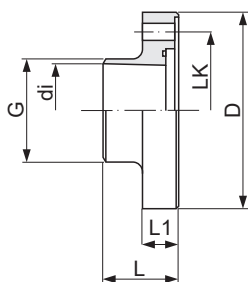
Weld socket for ODT/SMS	Sensor	Fits to	di	G	D	L	L1	LK
1.4404 / 316L 2*H**-V*****	DN [mm]	Piping OD/SMS	[mm]	[mm]	[mm]	[mm]	[mm]	[mm]
	40	38.1 × 1.65	35.3	40	92	42	19	71.0
	50	50.8 × 1.65	48.1	55	105	42	19	83.5
	65	63.5 × 1.65	59.9	66	121	42	21	100.0
	80	76.2 × 1.65	72.6	79	147	42	24	121.0
	100	101.6 × 1.65	97.5	104	168	42	24	141.5
<ul style="list-style-type: none"> - Fitting length for DN 40 to 65 = (2 × L) + 136 mm - Fitting length for DN 80 to 100 = (2 × L) + 196 mm - If pigs are used for cleaning, it is essential to take the inside diameters of measuring tube and process connection (di) into account! 								

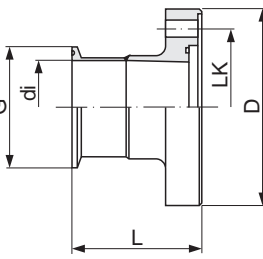
Clamp ISO 2852, Fig. 2	Sensor	Fits to piping	Clamp ISO 2852	di	G	D	L	LK
1.4404 / 316L 2*H**-W*****	DN [mm]	ISO 2037 / BS 4825-1	Diameter [mm]	[mm]	[mm]	[mm]	[mm]	[mm]
	40	38.0 × 1.6	38.0	35.6	50.5	92	68.5	71.0
	50	51.0 × 1.6	51.0	48.6	64.0	105	68.5	83.5
	65	63.5 × 1.6	63.5	60.3	77.5	121	68.5	100.0
	80	76.1 × 1.6	76.1	72.9	91.0	147	68.5	121.0
	100	101.6 × 2.0	101.6	97.6	119.0	168	68.5	141.5
<ul style="list-style-type: none"> - Fitting length for DN 40 to 65 = (2 × L) + 136 mm - Fitting length for DN 80 to 100 = (2 × L) + 196 mm - If pigs are used for cleaning, it is essential to take the inside diameters of measuring tube and process connection (di) into account! 								

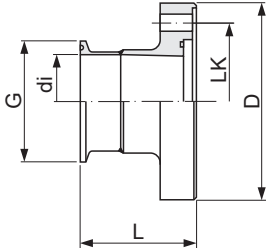
Clamp DIN 32676	Sensor	Fits to	di	G	D	L	LK
1.4404 / 316L 2*H**0*****	DN [mm]	Piping DIN 11850	[mm]	[mm]	[mm]	[mm]	[mm]
	40	42 × 2	38	50.5	92	61.5	71.0
	50	54 × 2	50	64.0	105	61.5	83.5
	65	70 × 2	66	91.0	121	68.0	100.0
	80	85 × 2	81	106.0	147	68.0	121.0
	100	104 × 2	100	119.0	168	68.0	141.5
<ul style="list-style-type: none"> - Fitting length for DN 40 to 65 = (2 × L) + 136 mm - Fitting length for DN 80 to 100 = (2 × L) + 196 mm ■ If pigs are used for cleaning, it is essential to take the inside diameters of measuring tube and process connection (di) into account! 							

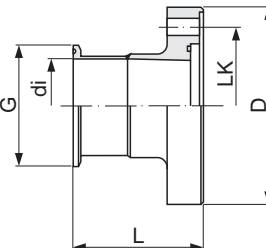
Tri-Clamp L14 AM7	Sensor		Fits to	di	G	D	L	LK
1.4404 / 316L 2*H**1*****	DN [mm]	DN [inch]	Piping OD	[mm]	[mm]	[mm]	[mm]	[mm]
	40	1½"	38.1 × 1.65	34.8	50.4	92	68.8	71.0
	50	2"	50.8 × 1.65	47.5	63.9	105	68.8	83.5
	65	-	63.5 × 1.65	60.2	77.4	121	68.8	100.0
	80	3"	76.2 × 1.65	72.9	90.9	147	68.8	121.0
	100	4"	101.6 × 1.65	97.4	118.9	168	68.8	141.5
<ul style="list-style-type: none"> - Fitting length for DN 40 to 65 = (2 × L) + 136 mm - Fitting length for DN 80 to 100 = (2 × L) + 196 mm ■ If pigs are used for cleaning, it is essential to take the inside diameters of measuring tube and process connection (di) into account! 								

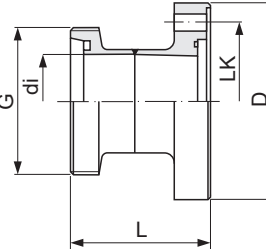
Coupling SC DIN 11851	Sensor	Fits to	di	G	D	L	LK
1.4404 / 316L 2*H**2*****	DN [mm]	Piping DIN 11850	[mm]	[mm]	[mm]	[mm]	[mm]
	40	42 × 2	38	Rd 65 × 1/6"	92	72	71.0
	50	54 × 2	50	Rd 78 × 1/6"	105	74	83.5
	65	70 × 2	66	Rd 95 × 1/6"	121	78	100.0
	80	85 × 2	81	Rd 110 × 1/6"	147	83	121.0
	100	104 × 2	100	Rd 130 × 1/6"	168	92	141.5
<ul style="list-style-type: none"> - Fitting length for DN 40 to 65 = (2 × L) + 136 mm - Fitting length for DN 80 to 100 = (2 × L) + 196 mm ■ If pigs are used for cleaning, it is essential to take the inside diameters of measuring tube and process connection (di) into account! 							

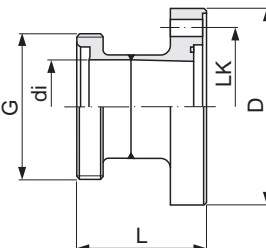
Coupling DIN 11864-1	Sensor	Fits to	di	G	D	L	LK
Aseptic threaded adapter, Form A 1.4404 / 316L 2*H**3*****	DN [mm]	Piping DIN 11850	[mm]	[mm]	[mm]	[mm]	[mm]
	40	42 × 2	38	Rd 65 × 1/6"	92	71	71.0
	50	54 × 2	50	Rd 78 × 1/6"	105	71	83.5
	65	70 × 2	66	Rd 95 × 1/6"	121	76	100.0
	80	85 × 2	81	Rd 110 × 1/6"	147	82	121.0
	100	104 × 2	100	Rd 130 × 1/6"	168	90	141.5
<ul style="list-style-type: none"> - Fitting length for DN 40 to 65 = (2 × L) + 136 mm - Fitting length for DN 80 to 100 = (2 × L) + 196 mm ■ If pigs are used for cleaning, it is essential to take the inside diameters of measuring tube and process connection (di) into account! 							

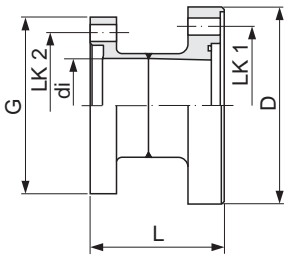
Flange DIN 11864-2	Sensor	Fits to	di	G	D	L	LK 1	LK 2
Aseptic flat flange, Form A 1.4404 / 316L 2*H**-4*****	DN [mm]	Piping DN 11850	[mm]	[mm]	[mm]	[mm]	[mm]	[mm]
	40	42 × 2	38	82	92	64	71.0	65
	50	54 × 2	50	94	105	64	83.5	77
	65	70 × 2	66	113	121	64	100.0	95
	80	85 × 2	81	133	147	98	121.0	112
	100	104 × 2	100	159	168	98	141.5	137
<ul style="list-style-type: none"> - Fitting length for DN 40 to 65 = (2 × L) + 136 mm - Fitting length for DN 80 to 100 = (2 × L) + 196 mm - If pigs are used for cleaning, it is essential to take the inside diameters of measuring tube and process connection (di) into account! 								

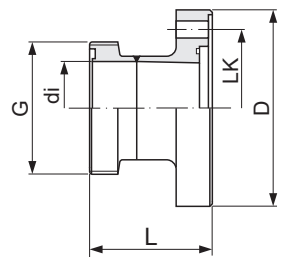
Coupling SMS 1145	Sensor	Fits to	SMS 1145	di	G	D	L	LK
Threaded adapter; 1.4404 / 316L 2*H**-5*****	DN [mm]	Piping OD	Dia- meter [mm]	[mm]	[mm]	[mm]	[mm]	[mm]
	40	38.1 × 1.65	38.0	35.5	Rd 60 × 1/6"	92	63	71.0
	50	50.8 × 1.65	51.0	48.5	Rd 70 × 1/6"	105	65	83.5
	65	63.5 × 1.65	63.5	60.5	Rd 85 × 1/6"	121	70	100.0
	80	76.2 × 1.65	76.0	72.0	Rd 98 × 1/6"	147	75	121.0
	100	101.6 × 1.65	101.6	97.6	Rd 132 × 1/6"	168	70	141.5
<ul style="list-style-type: none"> - Fitting length for DN 40 to 65 = (2 × L) + 136 mm - Fitting length for DN 80 to 100 = (2 × L) + 196 mm - If pigs are used for cleaning, it is essential to take the inside diameters of measuring tube and process connection (di) into account! 								

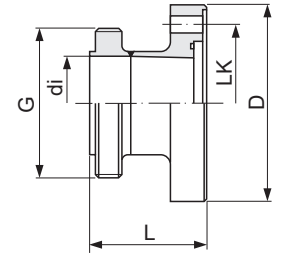
Coupling ISO 2853	Sensor	Fits to piping	ISO 2853	di	G	D	L	LK
Threaded adapter; 1.4404 / 316L 2*H**-6*****	DN [mm]	ISO 2037 / BS 4825-1	Diameter [mm]	[mm]	[mm]	[mm]	[mm]	[mm]
	40	38.0 × 1.6	38.0	35.6	50.6	92	61.5	71.0
	50	51.0 × 1.6	51.0	48.6	64.1	105	61.5	83.5
	65	63.5 × 1.6	63.5	60.3	77.6	121	61.5	100.0
	80	76.1 × 1.6	76.1	72.9	91.1	147	61.5	121.0
	100	101.6 × 2.0	101.6	97.6	118.1	168	61.5	141.5
<ul style="list-style-type: none"> - Fitting length for DN 40 to 65 = (2 × L) + 136 mm - Fitting length for DN 80 to 100 = (2 × L) + 196 mm - If pigs are used for cleaning, it is essential to take the inside diameters of measuring tube and process connection (di) into account! 								

Weight

Nominal diameter		Compact version (DIN)	
[mm]	[inch]	[kg]	[lbs]
2	1/12"	5.2	11.5
4	1/8"	5.2	11.5
8	3/8"	5.3	11.7
15	1/2"	5.4	11.9
25	1"	5.5	12.1
40	1 1/2"	6.5	14.3
50	2"	9.0	19.8
65	–	9.5	20.9
80	3"	19.0	41.9
100	4"	18.5	40.8

- Transmitter (compact version): 3.4 kg (7.5 lbs)
- Weight data valid for standard pressure ratings and without packaging material.

Measuring tube specifications

Nominal diameter		Pressure rating ¹⁾	Internal diameter ²⁾	
[mm]	[inch]	EN (DIN)	PFA	
		[bar]	[mm]	[inch]
2	1/12"	PN 16 / PN 40	2.25	0.09
4	1/8"	PN 16 / PN 40	4.5	0.18
8	3/8"	PN 16 / PN 40	9.0	0.35
15	1/2"	PN 16 / PN 40	16.0	0.63
–	1"	PN 16 / PN 40	22.6	0.89
25	–	PN 16 / PN 40	26.0	1.02
40	1 1/2"	PN 16	35.3	1.39
50	2"	PN 16	48.1	1.89
65	–	PN 16	59.9	2.36
80	3"	PN 16	72.6	2.86
100	4"	PN 16	97.5	3.84

¹⁾ Pressure rating depends on the process connection and the seals used.

²⁾ Internal diameter of process connections.

Material

- Transmitter housing:
 - powder coated die-cast aluminium
 - Sensor housing: stainless steel 1.4301/304
 - Wall mounting kit (holder panel): 1.4301/304
 - Lining material: PFA (USP Class VI; FDA 21 CFR 177.1550; 3A)
 - Measuring tube: stainless steel 1.4301/304
 - Flanges:
 - All connections 1.4404/316L
 - Flanges (EN (DIN), ANSI, JIS) made of PVDF
 - Adhesive fitting made of PVC
 - Grounding rings: 1.4435/316L (optional: Tantalum, Alloy C-22)
 - Electrodes:
 - Standard: 1.4435/316L
 - Optional: Alloy C-22, Tantalum, Platinum (up to DN 25 / 1" only)
 - Seals:
 - DN 2 to 25 (1/12 to 1"): O-Ring (EPDM, Viton, Kalrez), moulded seal (EPDM*, Viton, Silicone*)
 - DN 40 to 100 (1½ to 4"): moulded seal (EPDM*, Silicone*)
- * = USP Class VI; FDA 21 CFR 177.2600; 3A

Material load diagram



Caution!
 The following diagrams contain material load diagrams (reference curves) for flange materials with regard to the medium temperature.

**Weld socket to DIN EN ISO 1127, ODT/SMS;
 coupling to ISO 228 / DIN 2999 / NPT**
 Material: 1.4404 / 316L (with O-ring)

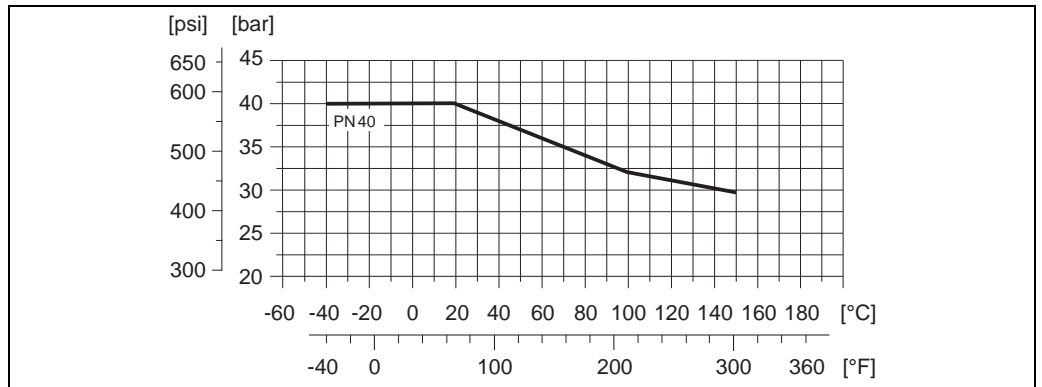

A0005586

**Weld socket to DIN 11850, ODT/SMS; Clamp (ISO 2852, DIN 32676, L14 AM7);
coupling (DIN 11851, DIN 11864-1, ISO 2853, SMS 1145), flange DIN 11864-2**
Material: 1.4404 / 316L (with moulded seal)

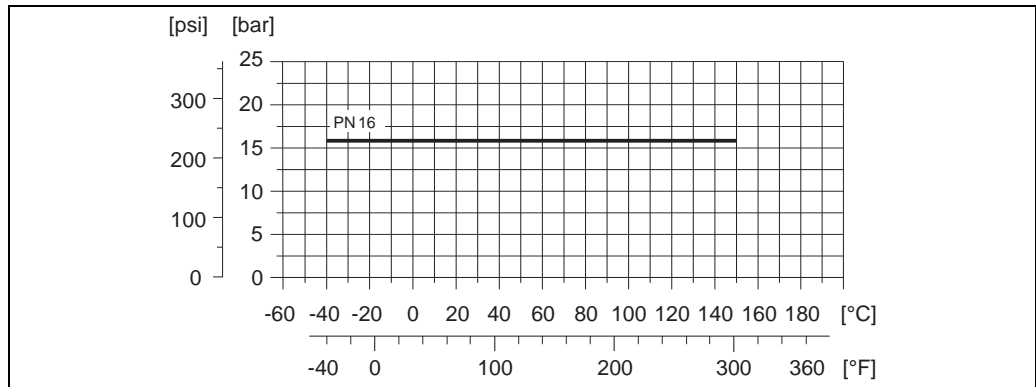

A0005596

Flange connection to EN 1092-1 (DIN 2501), adhesive fitting
Material: 1.4404 / 316L, PVDF, PVC-U

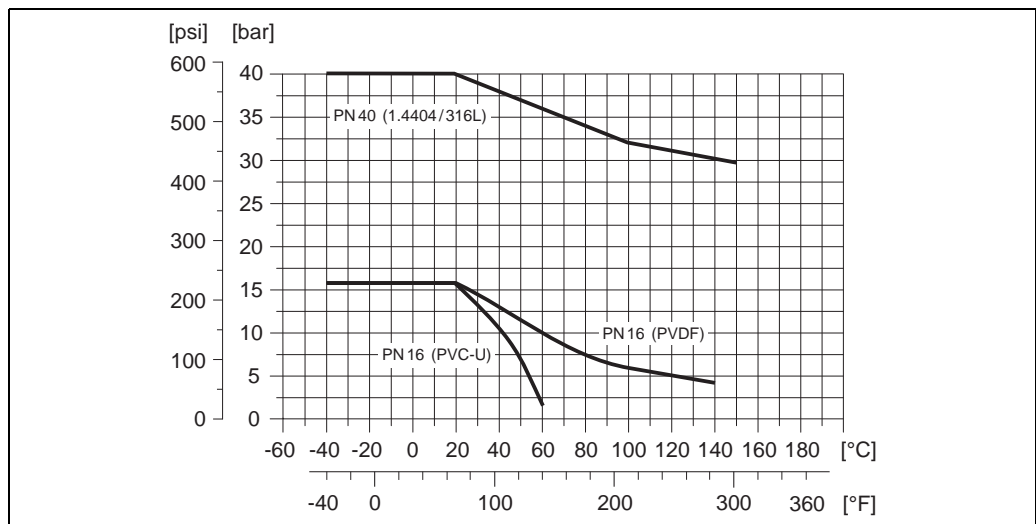

A0005597

Flange connection to ANSI B16.5
Material: 1.4404 / 316L, PVDF

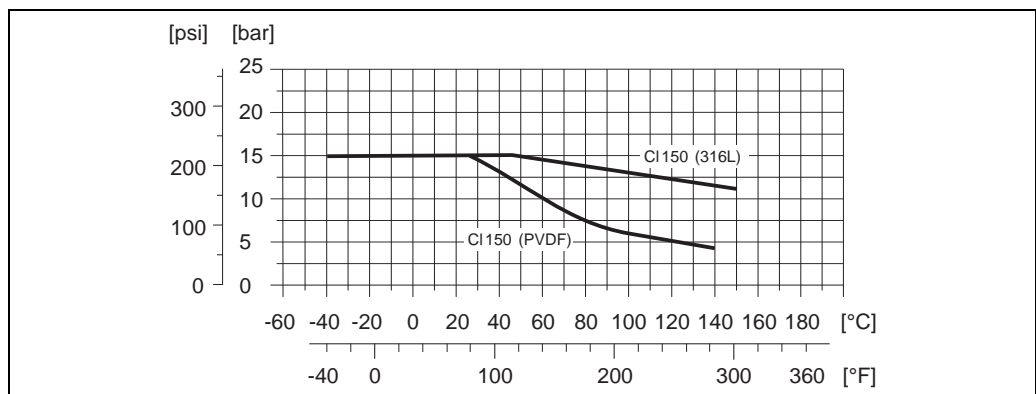

A0005598

Flange connection to JIS B2220

Material: 1.4404 / 316L, PVDF

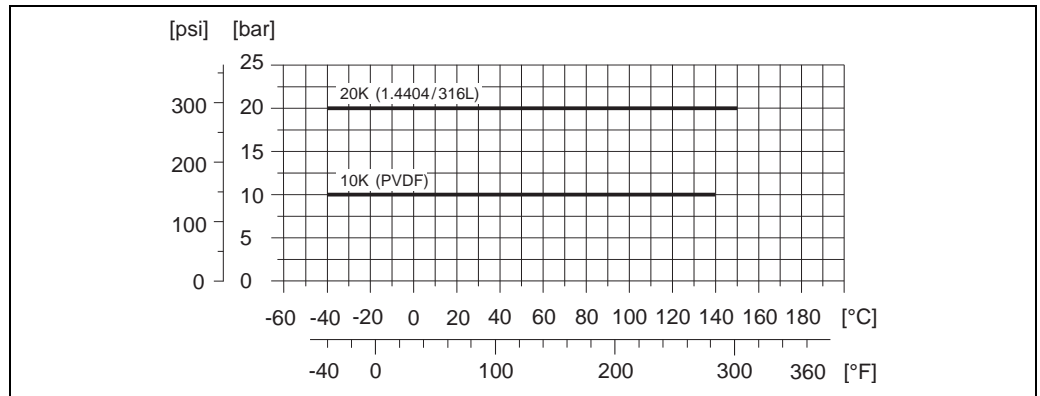

A0005599

Fitted electrodes

Measuring electrodes and empty pipe detection electrodes

- Standard with: 1.4435/316L, Alloy C-22, Tantalum, Platinum
- DN 2 to 15 (1/12 to 1/2"); without empty pipe detection electrode

Process connections

With O-ring:

- Weld sockets (DIN EN ISO 1127, ODT/SMS)
- Flange (EN (DIN), ANSI, JIS)
- PVDF flange (EN (DIN), ANSI, JIS)
- External pipe thread
- Internal pipe thread
- Hose connection
- PVC adhesive fittings

With gasket seals:

- Weld sockets DIN 11850, ODT/SMS
- Clamps (ISO 2852, DIN 32676, L14 AM7)
- Threaded joint DIN 11851, DIN 11864-1, ISO 2853, SMS 1145
- Flange DIN 11864-2

Surface roughness

(All data refer to parts in contact with medium)

- Measuring tube lining with PFA: $\leq 0.4 \mu\text{m}$ (15 μin)
- Electrodes
 - 1.4435/316L, Alloy C-22, Tantalum, Platinum: ≤ 0.3 to $0.5 \mu\text{m}$ (12 to 20 μin)
- Process connection made of stainless-steel: $\leq 0.8 \mu\text{m}$ (31 μin)

Human interface

Display elements

- Liquid-crystal display: illuminated, four lines with 16 characters per line
- Custom configurations for presenting different measured values and status variables
- 2 totalizers

Operating elements

- Onsite operation with three optical sensor keys (\square / \ast / E)

Language groups

via HART protocol

Certificates and approvals

CE mark	
C-tick mark	The measuring system meets the EMC requirements of the "Australian Communications and Media Authority (ACMA)".
Pressure measuring device approval	<p>The measuring devices can be ordered with or without PED (Pressure Equipment Directive). If a device with PED is required, this must be ordered explicitly. For devices with nominal diameters less than or equal to DN 25 (1"), this is neither possible nor necessary.</p> <ul style="list-style-type: none"> ■ Devices with this identification (with PED) are suitable for the following types of fluid: <ul style="list-style-type: none"> – Fluids of Group 1 and 2 with a steam pressure of greater or less than 0.5 bar (7.3 psi) – Unstable gases ■ Devices without this identification (without PED) are designed and manufactured according to good engineering practice. They correspond to the requirements of Art. 3, Section 3 of the Pressure Equipment Directive 97/23/EC. Their application is illustrated in Diagrams 6 to 9 in Appendix II of the Pressure Equipment Directive 97/23/EC.
Ex approval	
Other standards and guidelines	<ul style="list-style-type: none"> ■ EN 60529 Degrees of protection by housing (IP code) ■ EN 61010 Protection Measures for Electrical Equipment for Measurement, Control, Regulation and Laboratory Procedures. ■ IEC/EN 61326 "Emission in accordance with requirements for Class A". Electromagnetic compatibility (EMC requirements) ■ NAMUR NE 21: Electromagnetic compatibility (EMC) of industrial process and laboratory control equipment. ■ NAMUR NE 43: Standardization of the signal level for the breakdown information of digital transmitters with analog output signal. ■ NAMUR NE 53: Software of field devices and signal-processing devices with digital electronics. ■ ANSI/ISA-S82.01 Safety Standard for Electrical and Electronic Test, Measuring, Controlling and related Equipment – General Requirements Pollution degree 2, Installation Category II. ■ CAN/CSA-C22.2 No. 1010.1-92 Safety requirements for Electrical Equipment for Measurement and Control and Laboratory Use. Pollution degree 2, Installation Category II
Sanitary compatibility	<ul style="list-style-type: none"> ■ 3A approval and EHEDG-tested ■ Seals → conform to FDA (apart from Kalrez seals)

По вопросам продаж и поддержки обращайтесь:

Алматы (7273)495-231
Ангарск (3955)60-70-56
Архангельск (8182)63-90-72
Астрахань (8512)99-46-04
Барнаул (3852)73-04-60
Белгород (4722)40-23-64
Благовещенск (4162)22-76-07
Брянск (4832)59-03-52
Владивосток (423)249-28-31
Владикавказ (8672)28-90-48
Владимир (4922)49-43-18
Волгоград (844)278-03-48
Вологда (8172)26-41-59
Воронеж (473)204-51-73
Екатеринбург (343)384-55-89

Иваново (4932)77-34-06
Ижевск (3412)26-03-58
Иркутск (395)279-98-46
Казань (843)206-01-48
Калининград (4012)72-03-81
Калуга (4842)92-23-67
Кемерово (3842)65-04-62
Киров (8332)68-02-04
Коломна (4966)23-41-49
Кострома (4942)77-07-48
Краснодар (861)203-40-90
Красноярск (391)204-63-61
Курск (4712)77-13-04
Курган (3522)50-90-47
Липецк (4742)52-20-81

Магнитогорск (3519)55-03-13
Москва (495)268-04-70
Мурманск (8152)59-64-93
Набережные Челны (8552)20-53-41
Нижний Новгород (831)429-08-12
Новокузнецк (3843)20-46-81
Ноябрьск (3496)41-32-12
Новосибирск (383)227-86-73
Омск (3812)21-46-40
Орел (4862)44-53-42
Оренбург (3532)37-68-04
Пенза (8412)22-31-16
Петрозаводск (8142)55-98-37
Псков (8112)59-10-37
Пермь (342)205-81-47

Ростов-на-Дону (863)308-18-15
Рязань (4912)46-61-64
Самара (846)206-03-16
Санкт-Петербург (812)309-46-40
Саратов (845)249-38-78
Севастополь (8692)22-31-93
Саранск (8342)22-96-24
Симферополь (3652)67-13-56
Смоленск (4812)29-41-54
Сочи (862)225-72-31
Ставрополь (8652)20-65-13
Сургут (3462)77-98-35
Сыктывкар (8212)25-95-17
Тамбов (4752)50-40-97
Тверь (4822)63-31-35

Тольятти (8482)63-91-07
Томск (3822)98-41-53
Тула (4872)33-79-87
Тюмень (3452)66-21-18
Ульяновск (8422)24-23-59
Улан-Удэ (3012)59-97-51
Уфа (347)229-48-12
Хабаровск (4212)92-98-04
Чебоксары (8352)28-53-07
Челябинск (351)202-03-61
Череповец (8202)49-02-64
Чита (3022)38-34-83
Якутск (4112)23-90-97
Ярославль (4852)69-52-93

Россия +7(495)268-04-70

Казахстан +7(7172)727-132

Киргизия +996(312)96-26-47

эл.почта: ehr@nt-rt.ru || сайт: <https://endcounters.nt-rt.ru/>