

Электромагнитные расходомеры Proline Promag 33

Технические характеристики

По вопросам продаж и поддержки обращайтесь:

Алматы (7273)495-231
Ангарск (3955)60-70-56
Архангельск (8182)63-90-72
Астрахань (8512)99-46-04
Барнаул (3852)73-04-60
Белгород (4722)40-23-64
Благовещенск (4162)22-76-07
Брянск (4832)59-03-52
Владивосток (423)249-28-31
Владикавказ (8672)28-90-48
Владимир (4922)49-43-18
Волгоград (844)278-03-48
Вологда (8172)26-41-59
Воронеж (473)204-51-73
Екатеринбург (343)384-55-89

Иваново (4932)77-34-06
Ижевск (3412)26-03-58
Иркутск (395)279-98-46
Казань (843)206-01-48
Калининград (4012)72-03-81
Калуга (4842)92-23-67
Кемерово (3842)65-04-62
Киров (8332)68-02-04
Коломна (4966)23-41-49
Кострома (4942)77-07-48
Краснодар (861)203-40-90
Красноярск (391)204-63-61
Курск (4712)77-13-04
Курган (3522)50-90-47
Липецк (4742)52-20-81

Магнитогорск (3519)55-03-13
Москва (495)268-04-70
Мурманск (8152)59-64-93
Набережные Челны (8552)20-53-41
Нижний Новгород (831)429-08-12
Новокузнецк (3843)20-46-81
Ноябрьск (3496)41-32-12
Новосибирск (383)227-86-73
Омск (3812)21-46-40
Орел (4862)44-53-42
Оренбург (3532)37-68-04
Пенза (8412)22-31-16
Петрозаводск (8142)55-98-37
Псков (8112)59-10-37
Пермь (342)205-81-47

Ростов-на-Дону (863)308-18-15
Рязань (4912)46-61-64
Самара (846)206-03-16
Санкт-Петербург (812)309-46-40
Саратов (845)249-38-78
Севастополь (8692)22-31-93
Саранск (8342)22-96-24
Симферополь (3652)67-13-56
Смоленск (4812)29-41-54
Сочи (862)225-72-31
Ставрополь (8652)20-65-13
Сургут (3462)77-98-35
Сыктывкар (8212)25-95-17
Тамбов (4752)50-40-97
Тверь (4822)63-31-35

Тольятти (8482)63-91-07
Томск (3822)98-41-53
Тула (4872)33-79-87
Тюмень (3452)66-21-18
Ульяновск (8422)24-23-59
Улан-Удэ (3012)59-97-51
Уфа (347)229-48-12
Хабаровск (4212)92-98-04
Чебоксары (8352)28-53-07
Челябинск (351)202-03-61
Череповец (8202)49-02-64
Чита (3022)38-34-83
Якутск (4112)23-90-97
Ярославль (4852)69-52-93

Россия +7(495)268-04-70

Казахстан +7(7172)727-132

Киргизия +996(312)96-26-47

эл.почта: ehr@nt-rt.ru || сайт: <https://endcounters.nt-rt.ru/>

Electromagnetic Flow Measuring System

promag 33



Flexible System

- Wide choice of materials for process connections and measuring tube linings, compatible to the fluid
- Transmitter housing and display can be rotated to fit the orientation

Operational Security

- ISO 9001 manufacturer
- High electromagnetic compatibility (EMC)
- High operating integrity through self-monitoring with alarm function
- Data protection with EEPROM on power failure (without batteries)
- Empty Pipe Detection (EPD)

Easy to Operate

- Illuminated, double-spaced display
- Touch control: Operation from outside without opening the housing
- E+H operating matrix – menu-driven operation for all instrument parameters
- Interfaces: HART, PROFIBUS-PA, PROFIBUS-DP, Rackbus RS 485

Measure Precisely

- Measured error: $\pm 0.5\%$ or $\pm 0.2\%$
- 1000:1 operable flow range
- Excellent repeatability

Install Anywhere

- Robust, shock-resistant aluminium housing, resistant to acids and caustics
- IP 67 protection for compact and remote versions (optional IP 68 sensor)
- Wide size range DN 2...2000 ($1/12$...78")
- Flanged version with ISO meter lengths
- Hygienic sensor for food and pharmaceutical applications
- Ex versions for use in Ex Zones 1 and 2

Measuring System

Fields of Application

With the Promag 33 flowmeter most liquids can be measured provided they have a minimum conductivity of $\geq 5 \mu\text{S/cm}$, e.g.

- acids, alkalis, pastes, pulps,
- drinking water, wastewater, sewage sludge,
- milk, beer, wine, mineral water, yoghurt, molasses, etc.

A minimum conductivity of $\geq 20 \mu\text{S/cm}$ is required for measuring demineralised water.

Ex Versions

Promag 33 is available in a number of Ex versions for use in Ex Zone 1 and 2. More information is given in the appropriate Ex documentation. Your E+H representative will be pleased to help you.

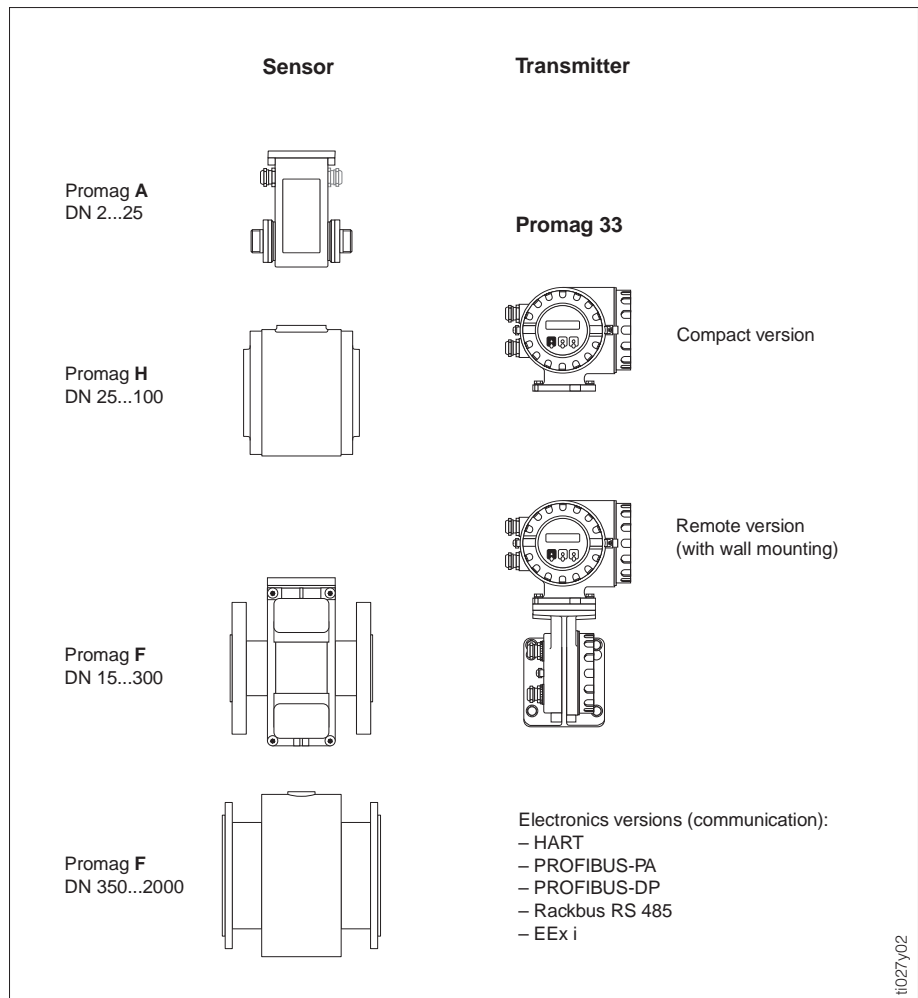

Measuring System

The measuring system consists of:

- Promag 33 transmitter
- Promag A, H or F sensor

The Promag 33 measuring system is mechanically and electronically designed for maximum flexibility with the transmitters and sensors being

combined in any variation. The wide range of materials and process connections (fittings; flanges DIN, ANSI, JIS; Tri-Clamp, etc.) ensure that the measuring point can adjust to both plant and process conditions.

Function

Measuring Principle

According to Faraday's Law of Magnetic Induction, a voltage is induced into a conductor which moves in a magnetic field. With the electromagnetic measuring principle, the flowing fluid is the moving conductor. The induced voltage is proportionally related to the flow velocity and is fed to the measuring amplifier by a pair of electrodes. Using the pipe cross-sectional area, the flow volume is calculated.

The DC magnetic field is generated by a switched direct current of alternating polarity. Together with the patented "Integrated Autozero Circuit", this guarantees a stable zero point, and makes the measurement fluid-independent and insensitive to entrained solid particles. Every meter is factory calibrated with the most modern calibration rigs, traceable to national standards.

Function of the Promag 33

The Promag transmitter converts the measured values coming from the sensor into standardised output signals. The following outputs are available for these signals:

- Current output
- Pulse / Frequency output
- Alarm output (Relay 1)
- Status output (Relay 2)

Promag 33 also has the following features:

- Relay 1 and 2 are freely configurable
- Auxiliary input (positive zero return, totalizer reset, batching, dual range mode)
- Empty Pipe Detection (EPD) detects and indicates partially filled or empty measuring tubes.
- The special electrode cleaning circuitry (EEC) ensures accurate flow measurement even with conductive build-up in the measuring tube (e.g. magnetite).

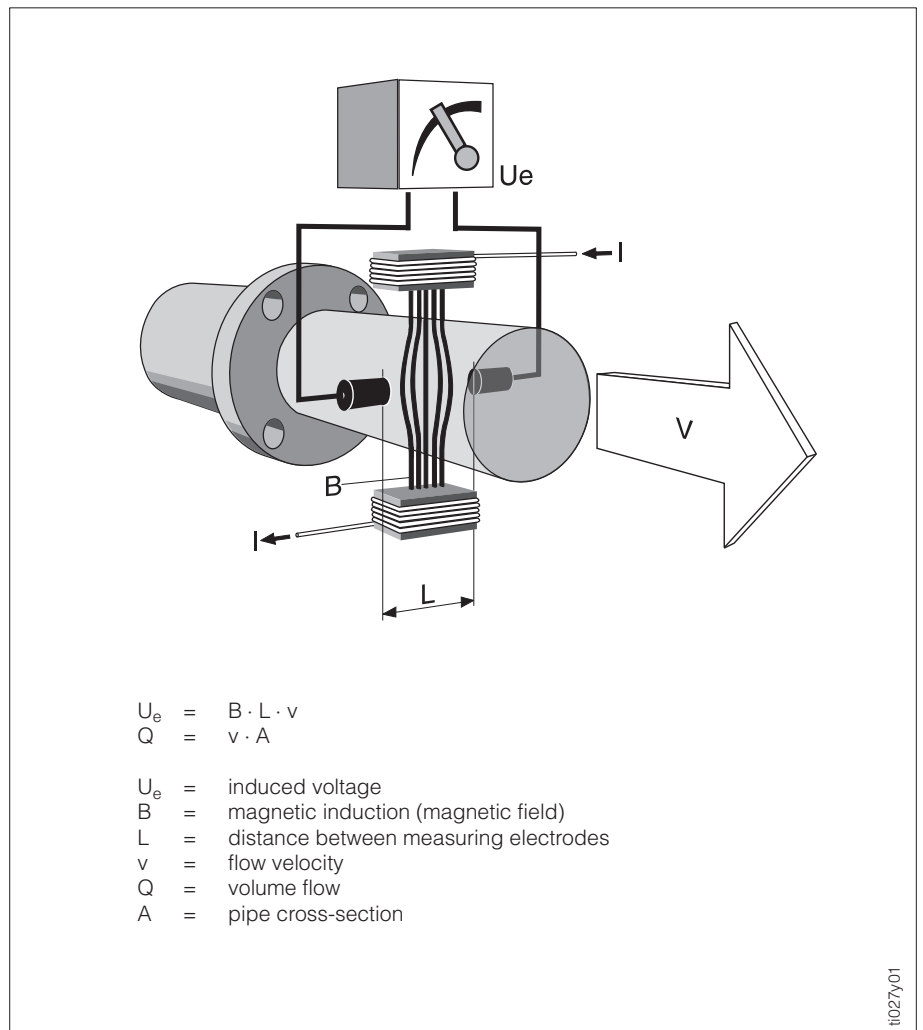

Operation

Display and Operation

The Promag 33 measuring system is equipped with an illuminated, double-spaced LC display. This ensures that all important variables can be read off and controlled directly at the measuring point:

- Technical units
- Current output functions
- Totalizer functions
- Pulse and frequency output functions
- Relay functions
- Limit values
- Batching functions with integral preset counter
- Display parameters

- Creep suppression
- Empty pipe detection (EPD)
- Single and bidirectional measurement
- Auxiliary input

Three operating keys are used for selecting and setting all functions of the instrument. The E+H operating matrix allows quick and easy access to all individual functions.

12 languages are selectable for the display text. A help function (diagnosis function) is available during programming.

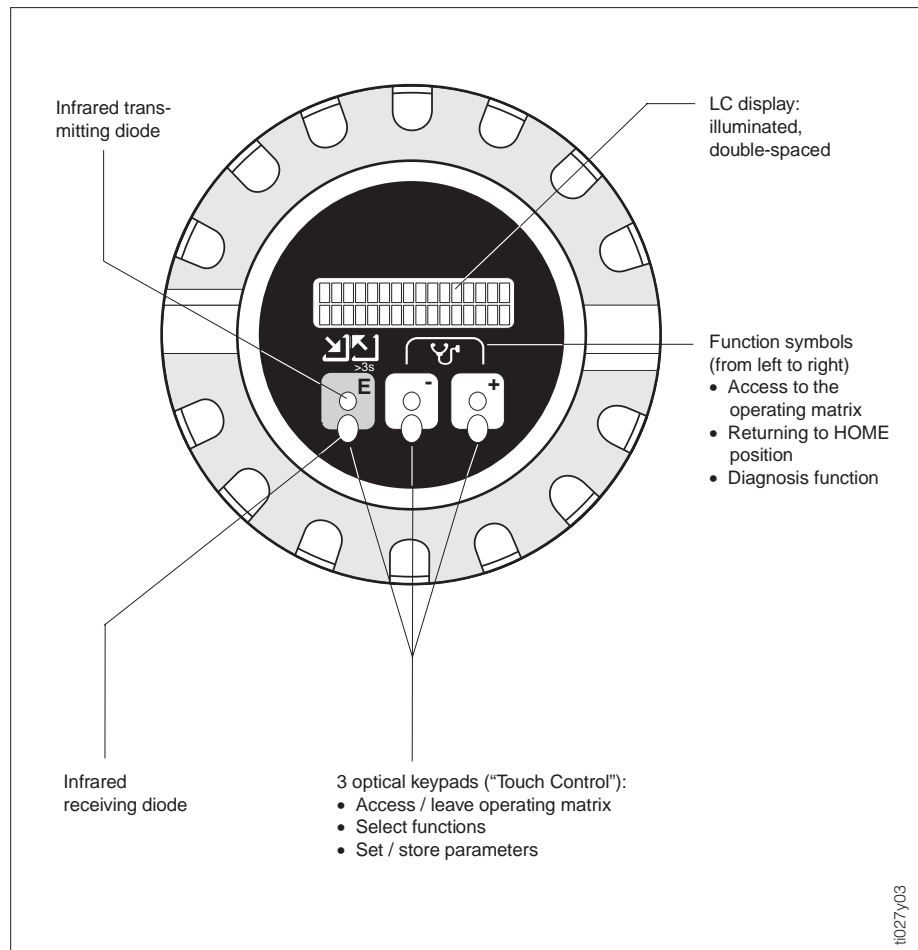

Communication

Depending on which module is fitted, Promag 33 has different interfaces for communication ability with higher level systems:

- HART protocol (SMART technology) is possible on the current output.
- Direct communication to a personal computer and the E+H Rackbus world is possible via the RS 485 interface.

- The PROFIBUS-PA version provides an indirect connection to process control systems via segment couplers.
- Promag 33 is also available as a PROFIBUS-DP version for connecting to a PROFIBUS-DP network.

This communication feature enables operation and configuration of instruments which have no local display.

Diameter Selection

As a rule, the pipe diameter determines the sensor nominal diameter.

A necessary increase in velocity can be achieved through a reduction of the sensor diameter (see page 8).

The higher installation expense is normally balanced by the lower sensor cost.

The flow velocity (v) is also to be determined by the fluid's physical properties:

- $v < 2$ m/s: with abrasive fluids, e.g. potter's clay, lime milk, ore slurry
- $v > 2$ m/s: with fluids causing build up, e.g. wastewater slurry etc.

The table below summarizes the minimum and maximum full scale values for the current output (incl. factory settings).

DN		Full scale values [m ³ /h]		
[mm]	[inch]	Minimum full scale at $v = 0.3$ m/s	Factory setting at $v \sim 2.5$ m/s	Maximum full scale at $v = 10$ m/s
2	1/12"	0.0034	0.0283	0.1131
4	5/32"	0.0136	0.1131	0.4524
8	5/16"	0.0543	0.4524	1.810
15	1/2"	0.1908	1.590	6.362
25	1"	0.5301	4.418	17.67
32	1 1/4"	0.8685	7.238	28.95
40	1 1/2"	1.357	11.31	45.24
50	2"	2.121	17.67	70.69
65	2 1/2"	3.584	29.87	119.5
80	3"	5.429	45.24	181.0
100	4"	8.482	70.69	282.7
125	5"	13.25	110.5	441.8
150	6"	19.09	159.0	636.2
200	8"	33.93	282.7	1130
250	10"	53.01	441.8	1767
300	12"	76.34	636.2	2545
350	14"	103.9	865.9	3464
400	16"	135.7	1131	4524
450	18"	171.8	1431	5726
500	20"	212.1	1767	7069
600	24"	305.4	2545	10179
700	28"	415.6	3464	13854
750	30"	477.1	3976	15904
800	32"	542.9	4524	18096
900	36"	687.1	5726	22902
1000	40"	848.2	7069	28274
1050	42"	935.2	7793	31172
1200	48"	1222	10179	40715
1350	54"	1546	12882	51530
1400	56"	1663	13854	55418
1500	60"	1909	15904	63617
1600	64"	2172	18096	72382
1700	66"	2451	20428	81713
1800	72"	2748	22902	91609
2000	78"	3393	28274	113097

Mounting

In order to measure correctly and to prevent damage, please observe the following installation instructions.

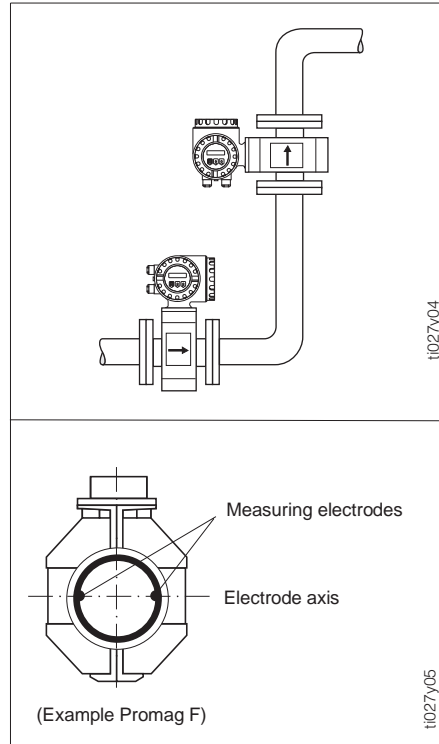

Mounting Position

Vertical mounting:

This is the recommended position with the flow upwards. Entrained solid particles sink and fatty components in the stationary fluid rise away from the measuring electrodes. This is the optimal position in empty pipe system and when using Empty Pipe Detection.

Horizontal mounting:

The axis of the electrodes must be horizontal, thus preventing brief insulation of the electrodes by entrained air bubbles.

Electrode axis:

The plane in which the electrode axis lies with regard to the transmitter is identical for the Promag A, H and F sensors.

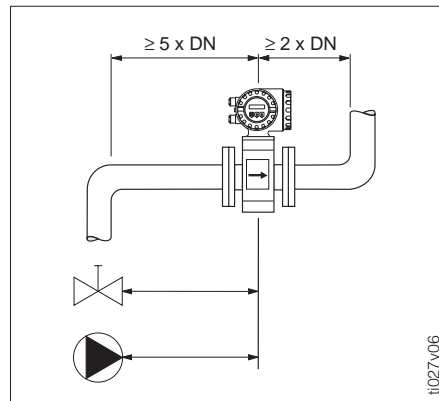

Inlet and Outlet Sections

The sensor should be mounted away from fittings such as valves, T-pieces, elbows, etc.

Inlet section: $\geq 5 \times \text{DN}$

Outlet section: $\geq 2 \times \text{DN}$

The inlet and outlet sections must be observed in order to maintain accuracy.

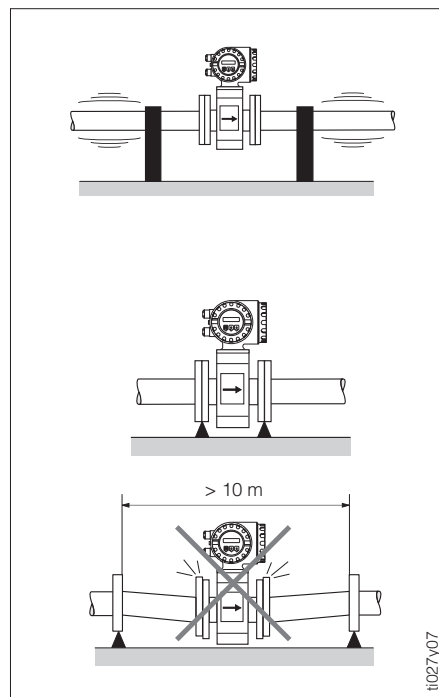

Vibration

The piping before and after the sensor should be securely fastened if there is excessive vibration. Information on shock and vibration resistance is found on page 25.

Excessive vibration necessitates separate mounting of the sensor and transmitter.

Mechanical support of the sensor is recommended for free runs of piping over 10 m long.

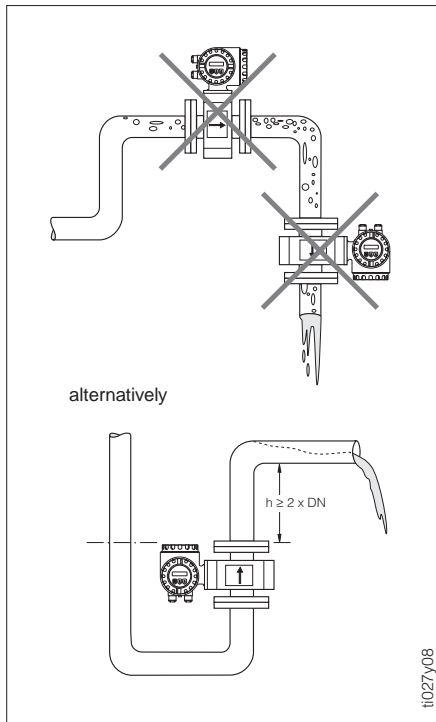

Mounting Location

Correct measurement is only possible when the pipe is full. The following locations should therefore be avoided:

- No installation at the highest point (air accumulation).
- No installation immediately before an open pipe outlet in a downward line.

The alternative installation, however, permits a correct measurement.

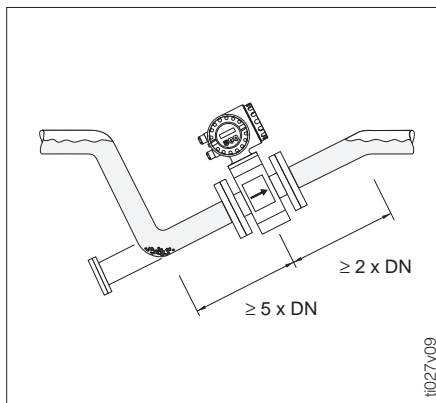

Partly Filled Pipes

For inclines a mounting similar to a drain should be adopted. Added security is offered by Empty Pipe Detection (EPD) in order to detect empty or partly filled pipes.

Note!

Danger of solids accumulation!
Do not mount the sensor at the lowest point of the drain. A cleaning valve should also be installed.

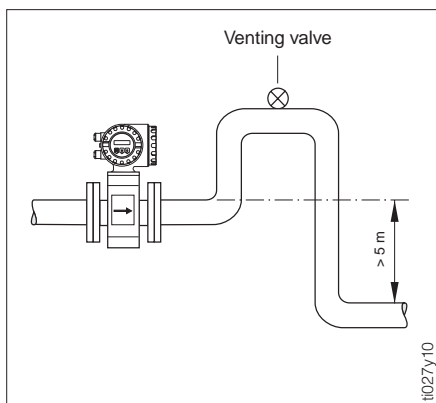

Downward Pipe

With the installation suggested opposite, partial vacuum is avoided even with a downward pipe $> 5 \text{ m}$ long (siphon, vent valve downstream of the sensor).

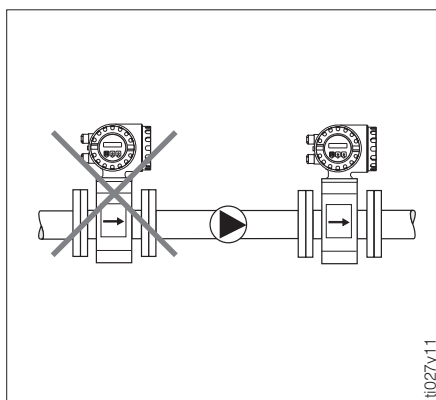

Installation of Pumps

Do not mount the sensors on the suction side of pumps.

This prevents low pressure and prevents possible damage to the lining of the measuring tube.

Pulse dampers should be installed when using reciprocal, diaphragm or peristaltic pumps.

Mounting

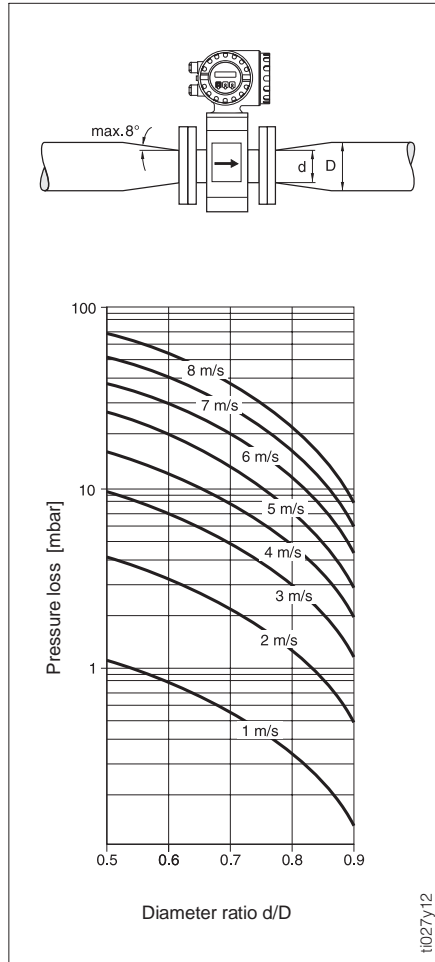

Adapters

The sensor can also be mounted in a pipe with a larger nominal diameter when suitable adapters (reducers and expanders) to DIN 28545 are fitted. The resultant increase in the rate of flow increases the accuracy of measurement with slowly moving fluids.

The adjacent nomogram can be used to determine the pressure loss caused:

1. Determine the ratio of the diameter d/D .
2. From the nomogram read off the pressure loss at the flow velocity and d/D ratio.

Note!

The nomogram applies to fluids with a viscosity similar to that of water.

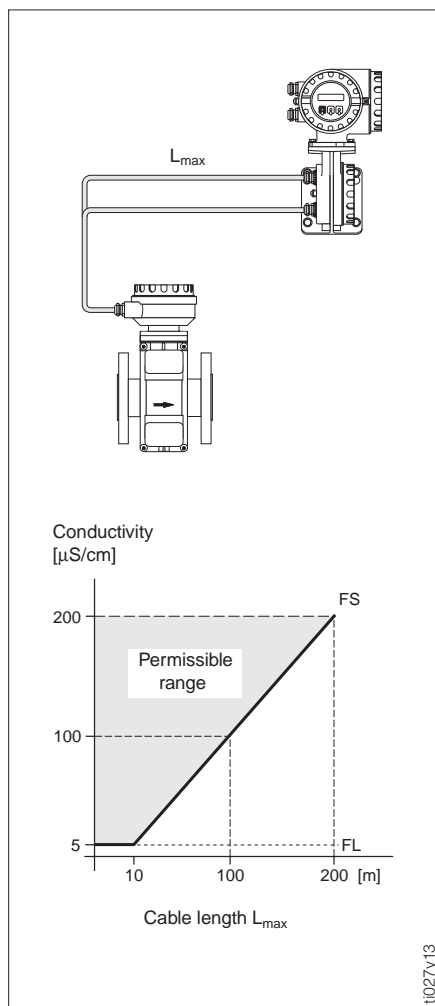

Remote Version

Two different versions are available for the remote version:

FS version

- The permissible cable length greater than 10 meters is governed by the fluid conductivity (see Figure).
- Permissible cable length of max. 10 meters if the instrument is equipped with an Empty Pipe Detection (EPD) electrode.
- The FS cable is recommended only for distances smaller than 20 m.

FL version

- All fluids with a minimum conductivity of $\geq 5 \mu\text{S/cm}$ (demineralised water $\geq 20 \mu\text{S/cm}$) can be measured independent of the cable length.
- Empty Pipe Detection (EPD) is not available with this version.

Please also note the following:

- Fasten the cable gland or lay it in a conduit. When the fluid conductivity is low, cable movements can cause serious changes in capacitance and thereby falsify the measuring signal.
- Do not run the cable in the vicinity of electrical machines or switching elements.
- Ensure potential equalisation between the transmitter and the sensor.

Remote version has to be mounted when:

- access is difficult
- space is restricted
- extreme process and ambient temperatures prevail (see page 24)
- there is severe vibration (see page 25)

Electrical Connection Transmitter

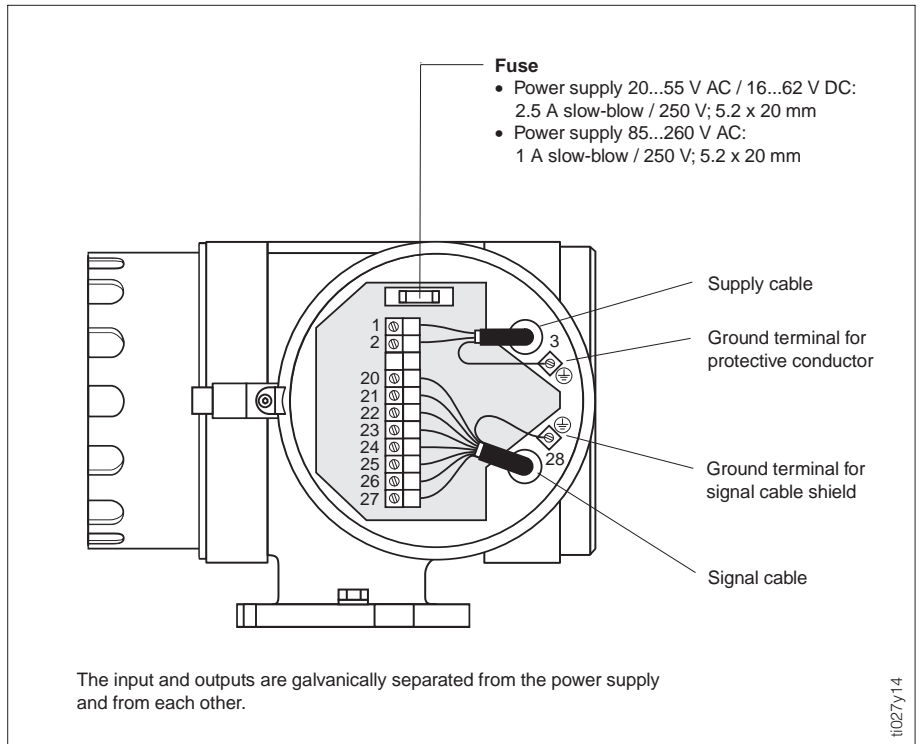

"HART" version		
3	Ground connection (protective earth)	
1 2	L1 N for AC power supply	L+ L- for DC power supply
20 (+) 21 (-)	Pulse / Frequency output	active/passive, $f_{max} = 10$ kHz active: 24 V DC, 25 mA (max. 250 mA/20 ms) passive: 30 V DC, 250 mA
22 (+) 23 (-)	Alarm output (Relay 1)	can be configured max. 60 V AC / 0.5 A AC; max. 30 V DC / 0.1 A DC
24 (+) 25 (-)	Status output (Relay 2)	can be configured max. 60 V AC / 0.5 A AC; max. 30 V DC / 0.1 A DC
26 (+) 27 (-)	Current output	active, 0/4...20 mA, $R_L < 700 \Omega$ (with HART: $R_L \geq 250 \Omega$)
28	Ground connection (screening of signal cable)	

"PROFIBUS-PA" version		
3	Ground connection (protective earth)	
1 2	L1 N for AC power supply	L+ L- for DC power supply
20 / 21	not used	
22 (+) 23 (-)	Current output	active, 0/4...20 mA $R_L < 350 \Omega$
24 / 25	not used	
26 (+) 27 (-)	PROFIBUS-PA	EN 50170 Volume 2, IEC 1158-2
28	Ground connection (screening of signal cable)	

"PROFIBUS-DP" version		
3	Ground connection (protective earth)	
1 2	L1 N for AC power supply	L+ L- for DC power supply
20-25	not used	
26 (+) 27 (-)	Data B Data A PROFIBUS-DP	(RS 485 interface)
28	Ground connection (screening of signal cable)	

Electrical Connection Transmitter

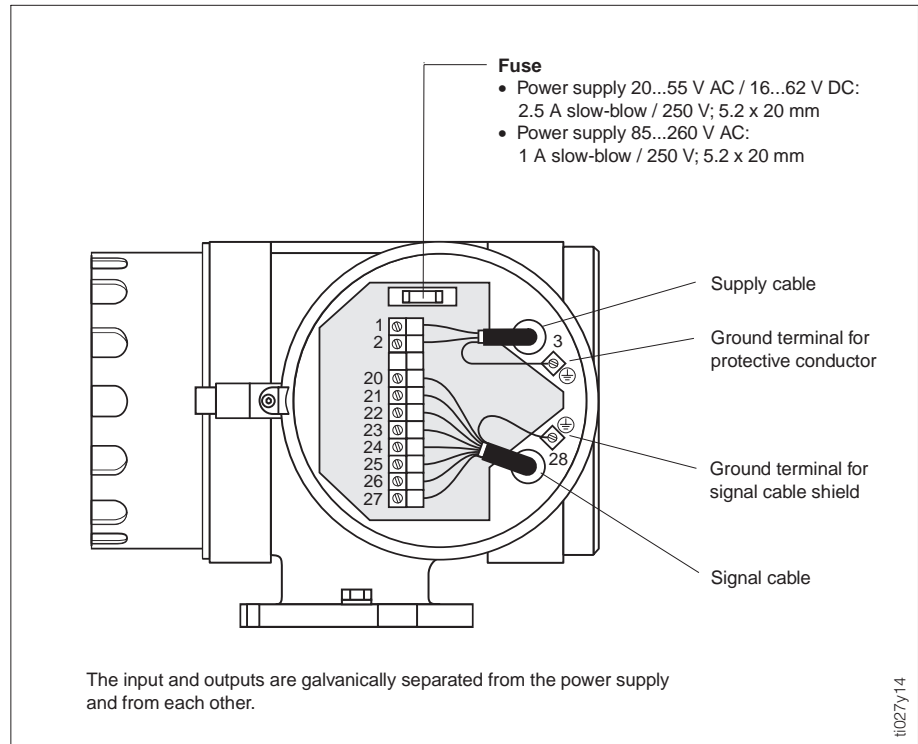

“Rackbus RS 485” version

3	Ground connection (protective earth)	
1 2	L1 N for AC power supply	L+ L- for DC power supply
20 (+) 21 (-)	RS 485 interface A B	or Auxiliary input + / - 3...30 V DC - / +
22 (+) 23 (-)	Alarm output (Relay 1)	can be configured max. 60 V AC / 0.5 A AC; max. 30 V DC / 0.1 A DC
24 (+) 25 (-)	Status output (Relay 2)	can be configured max. 60 V AC / 0.5 A AC; max. 30 V DC / 0.1 A DC
26 (+) 27 (-)	Current output or Pulse/frequency output	active, 0/4...20 mA, $R_L < 700 \Omega$ active/passive, $f_{max} = 10 \text{ kHz}$ active: 24 V DC, 25 mA (max. 250 mA/20 ms) passive: 30 V DC, 250 mA
28	Ground connection (screening of signal cable)	

“EEx i” version

3	Ground connection PE (protective earth)	
1 2	L1 N for AC power supply	L+ L- for DC power supply
20 / 21	not used	
22 (+) 23 (-)	Current output	active, 0/4...20 mA, $R_L < 350 \Omega$ (with HART: $R_L \geq 250 \Omega$)
24 / 25	not used	
26 (+) 27 (-)	Pulse/frequency output	passive, $f_{max} = 10 \text{ kHz}$ Can be used as NAMUR contact acc. to DIN 19234
28	Ground connection (screening of signal cable)	

Terminal compartment with:

- a special terminal block for intrinsically safe outputs and
- an IP 40 cover for power supply terminals.

Electrical Connection Remote Version

FS Version

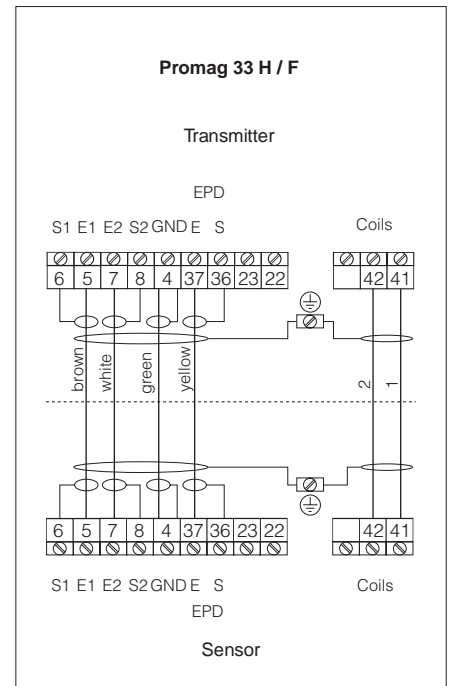
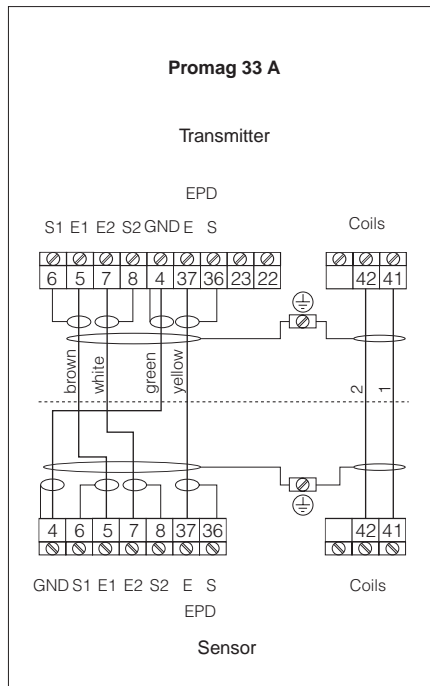

FL Version

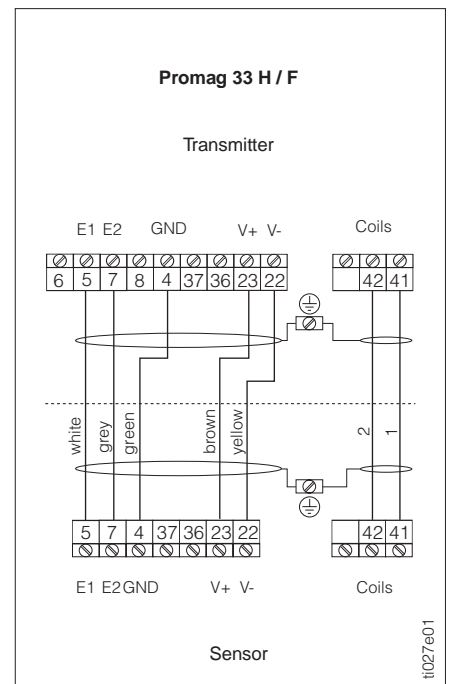
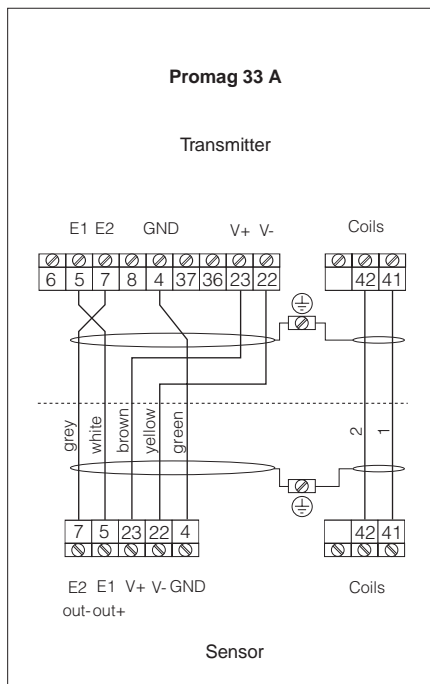

ti027e01

Cable Specifications

Remote Version "FS"

Coil cable: 2 x 0.75 mm² PVC cable with common screen *
Conductor resistance ≤ 37 Ω/km
Capacitance: core/core, screen grounded ≤ 120 pF/m
Permanent operating temperature: -20...+70 °C

Signal cable: 3 x 0.38 mm² PVC cable with common screen *
and separately screened cores
With EPD (Empty Pipe Detection) 4 x 0.38 mm² PVC cable
Conductor resistance ≤ 50 Ω/km
Capacitance: core/screen ≤ 420 pF/m
Permanent operating temperature: -20...+70 °C

* braided copper screen: Ø ~ 7 mm

Remote Version "FL"

Coil cable: 2 x 0.75 mm² PVC cable with common screen *
Conductor resistance ≤ 37 Ω/km
Capacitance: core/core, screen grounded ≤ 120 pF/m
Permanent operating temperature: -20...+70 °C

Signal cable: 5 x 0.5 mm² PVC cable with common screen *
Conductor resistance ≤ 37 Ω/km
Capacitance: core/core, screen grounded ≤ 120 pF/m
Permanent operating temperature: -20...+70 °C

* braided copper screen:
coil cable Ø ~ 7 mm; signal cable Ø ~ 9 mm

Operation in Areas with Severe Electrical Interference

The Promag 33 measuring system fulfils all general safety requirements according to EN 61010 and electromagnetic compatibility (EMC) according to EN 50081 Part 1 and 2 / EN 50082 Part 1 and 2 when installed in accordance with the NAMUR recommendations.

Note!

- To comply with the certificate of conformity, the signal and coil cables between the sensor and transmitter of the remote version must always be screened and grounded at both ends. Grounding is made using the ground terminals especially for this purpose on the inside of the connection housings. Keep stripped and twisted cable shield section to the ground terminal as short as possible.
- The cable must be resistant to an ambient temperature of max. +80 °C if the Promag H sensor is operated at a process temperature of +150 °C.

Potential Equalisation

The sensor and the fluid must have roughly the same electrical potential to ensure that measurement is accurate and no galvanic corrosion takes place at the electrode.

Normally the reference electrode in the sensor or the metal pipe ensures that the potentials are equalised.

Reference electrodes:

Promag A:
Always with reference electrode

Promag F:
Optional, depending on material

Promag H:
No reference electrode, as there is always a metallic connection to the fluid.

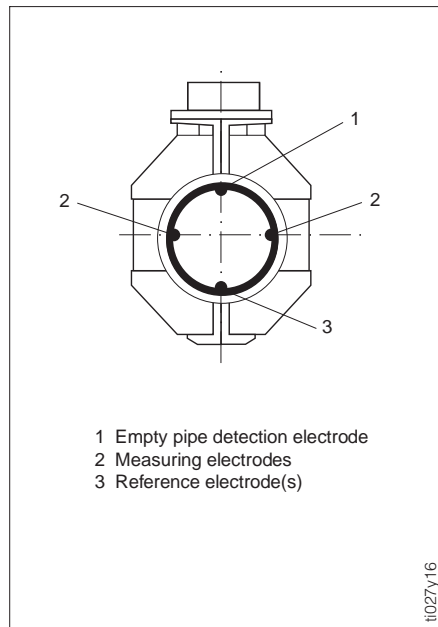

If the reference electrode is correctly grounded and the fluid flows through metallic, non-lined and grounded piping, then it is sufficient to connect the grounding terminal of the Promag 33 transmitter housing to the potential equalisation line in order to prevent corrosion. The connection with the remote-mounted version is made at the ground terminal of the connection housing.

Caution!

Danger of permanent damage to the instrument! If the fluid cannot be grounded for operational reasons, ground disks are to be used.

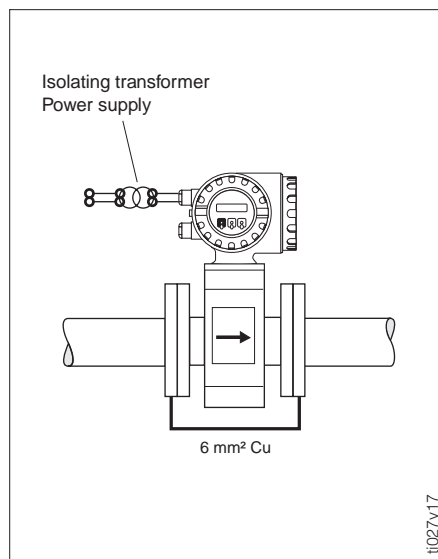

Potential Equalisation for Lined Pipes with Cathodic Protection

When the fluid cannot be grounded for operational reasons, the measuring unit must be installed that it is potential-free. Ensure that components of the piping are connected to one another (copper wire, 6 mm²).

All national regulations regarding potential free installation are to be observed (e.g. VDE 0100). Ensure that the mounting material used does not result in a conductive bond with the measuring unit and that the material can withstand the tightening torque used.

Potential Equalisation

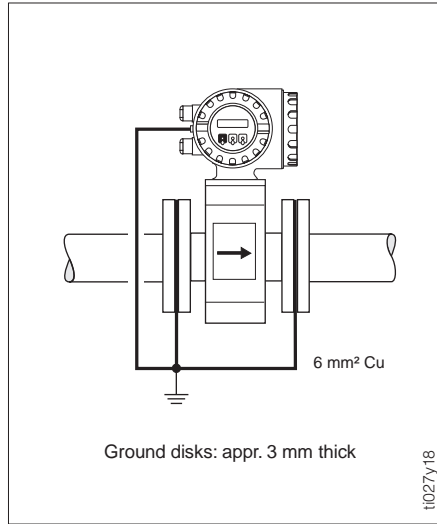

Plastic or Lined Piping

Ground disks must always be used with non-conductive piping materials if compensation currents flow through the fluid. They can irreparably damage the reference electrode within a short time due to electrochemical corrosion.

Such conditions occur especially if:

- the piping is insulated with electrically non-conductive materials and
- the piping is made of fibreglass or PVC through which flow highly concentrated acids and alkalis.

Caution!

Danger from damage due to electrochemical corrosion!

- Note the corrosion resistance of the ground disks.
- Note the electrochemical potential series in cases where the ground disks and the measuring electrodes are made of different material.

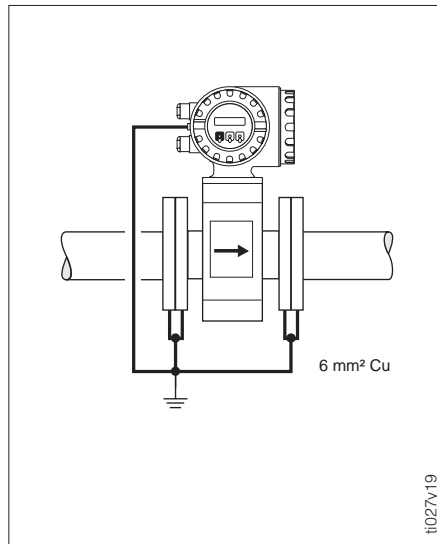

Equalising Currents in Ungrounded Metal Pipes / Grounding in an Area with Severe Interference

The fluid may be grounded. In order to make the most of the electromagnetic compatibility (EMC) of the Promag 33, it is advisable to provide two flange-to-flange links and to connect them jointly with the transmitter housing to ground potential.

Wall mounting kit Promag A

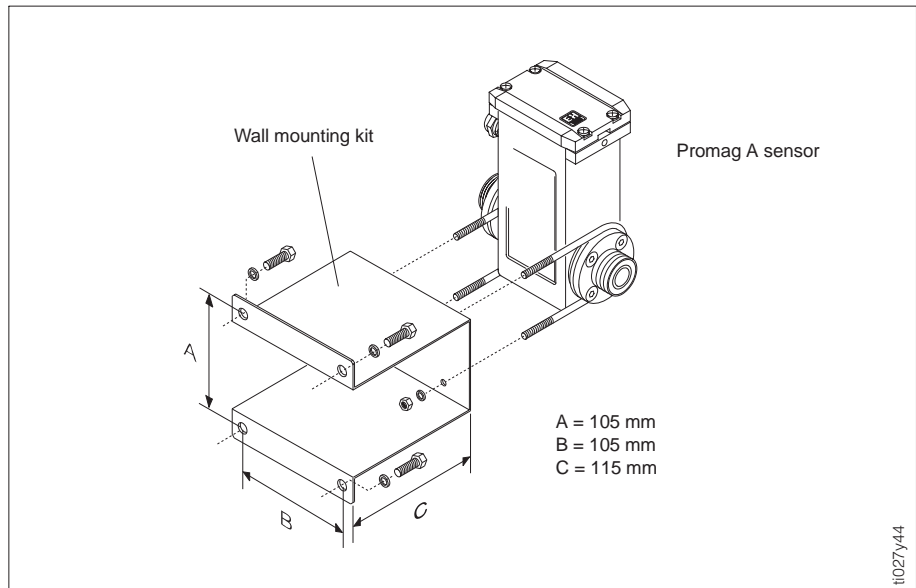

Dimensions Promag 33 A

Compact version

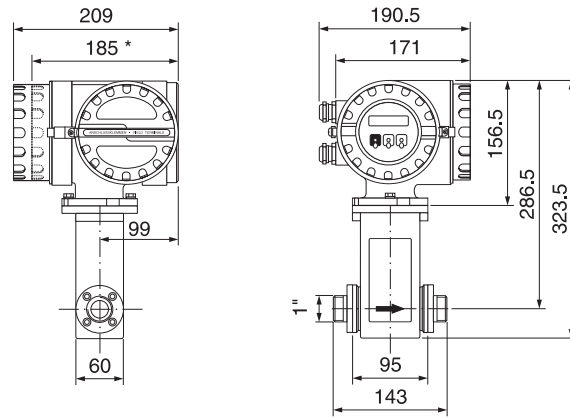

Remote version

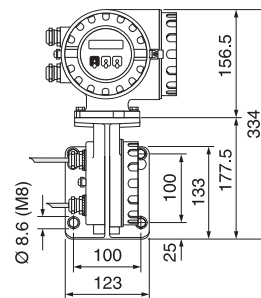
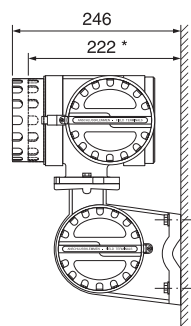

FS version

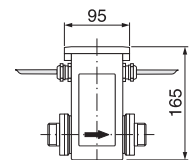
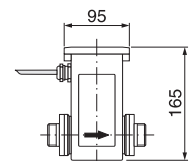

FL version

Weight:

Compact version	5 kg (without process connections)
Promag 33 transmitter	3 kg (5 kg for wall mounted version)
Promag A sensor	2 kg

* with blind version

t027y20

t027y21

Can be ordered separately as mounting set:
Internal thread, external thread, PVC adhesive
coupling, hose connection, welded nipples

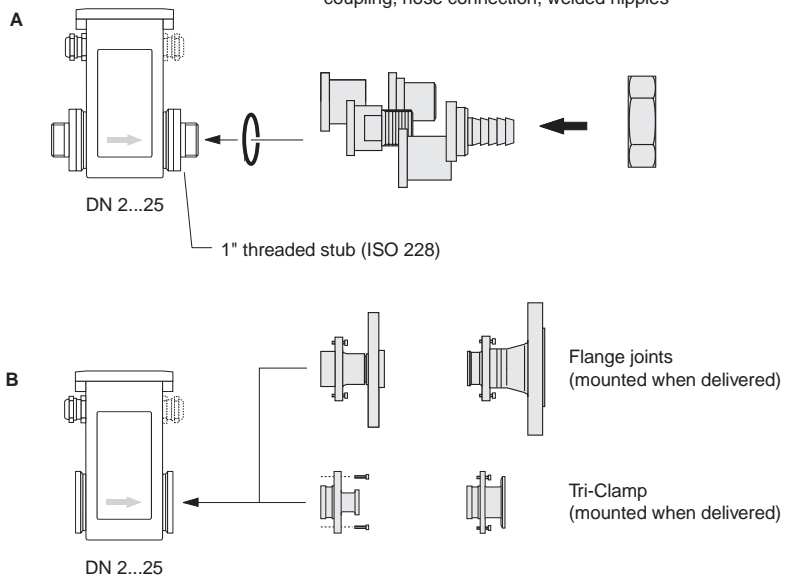

Process connections Promag A
(Dimensions: see page 16)

A Mounting set:
coupling nut on a 1" threaded
stub

B Screw-in process connections
(instead of threaded stub)

t027y23

Process Connections Promag A

Internal thread
standard thread:
ISO 228/DIN 2999

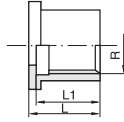

DN	L	L1	Thread
2...15	20	18	1/2"
2...15	20	18	1/2" NPT
25	45	22	1"
25	45	22	1" NPT

External thread
standard thread:
ISO 228/DIN 2999

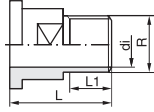

DN	L	L1	di	Thread
2...15	35	13.2	16.1	1/2"
2...15	42	20.0	16.1	1/2" NPT
25	50	16.8	22.0	1"
25	60	25.0	22.0	1" NPT

PVC adhesive coupling

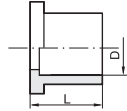

DN	L	D	Pipe connection
2...15	19	20.0	20 · 2
2...15	20	21.5	1/2"
25	66	25.0	25 · 2
25	69	32.0	32 · 2.5
25	69	33.5	1"

Hose connection

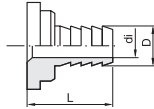

DN	L	D	di	LW
2...15	30	14.5	8.9	13
2...15	30	17.5	12.6	16
2...15	30	21.0	16.1	19

LW = Internal diameter hose

**Welded nipple
DN 2...15**

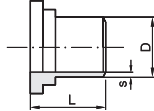

DN	L	D	s	Pipe connection
2..15	20	21.3	2.6	1/2"
2..15	20	21.3	2.6	18 · 1

**Welded nipple
DN 25**

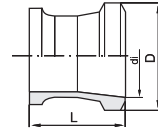

DN	L	D	di	Pipe connection
25	30	33.7	26.0	1"
25	30	33.7	26.0	28 · 1
25	20	25.4	22.1	25.4 · 1.6 / 1"

Tri-Clamp
Stainless steel
1.4404/316L

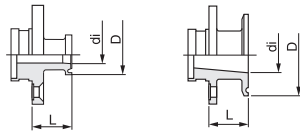

DN	L	D	di	Pipe connection
2..8	24	25.0	9.5	1/2"
15	24	25.0	16.0	3/4"
2..8	24	50.4	22.1	1"
15	24	50.4	22.1	1"
25	24	50.4	22.1	1"

Flange
Stainless steel 1.4404/316L
with joint dimensions to
DIN 2501/ANSI B16.5/JIS B2210

DN 2...15:
with DN 15 or 1/2" flanges

DN 25:
with DN 25 or 1" flanges

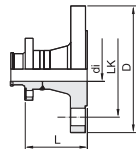

Flange to DIN 2501, PN 40

DN	L	D	di	LK
2...8	51.8	95	17.3	65
15	51.8	95	17.3	65
25	51.8	115	28.5	85

Flange to ANSI B16.5

DN	Class 150				Class 300		
	L	D	LK	di	L	D	LK
2...8	61.6	88.9	60.5	15.8	61.6	95.2	66.5
15	61.6	88.9	60.5	15.8	61.6	95.2	66.5
25	67.4	108.0	79.2	26.6	73.8	123.9	88.9

Flange to JIS B2210

DN	L	D	di	LK
2...8	62.5	95	15	70
15	62.5	95	16	70
25	62.5	115	25	90

Face-to-face length to DVGW (200 mm)

Flange
PVDF with joint dimensions to
DIN 2501/ANSI B16.5/JIS B2210

DN 2...15:
with DN 15 or 1/2" flanges

DN 25:
with DN 25 or 1" flanges

Length:
2 x L + 143 mm
2 x L + 95 mm (for flanged or
Tri-Clamp version)

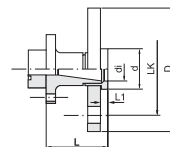

All dimensions in [mm]

y22-01...10

Flange to DIN 2501/ANSI B16.5/JIS B2210
PN 16/Class 150/10K

DN	L	L1	D	d	di	DIN LK	ANSI LK	JIS LK
2...8	52.7	6	95	34	16.2	65	60.5	70
15	52.7	6	95	34	16.2	65	60.5	70
25	52.7	7	115	50	27.2	85	79.2	90

Face-to-face length to DVGW (200 mm)

Dimensions Promag 33 H

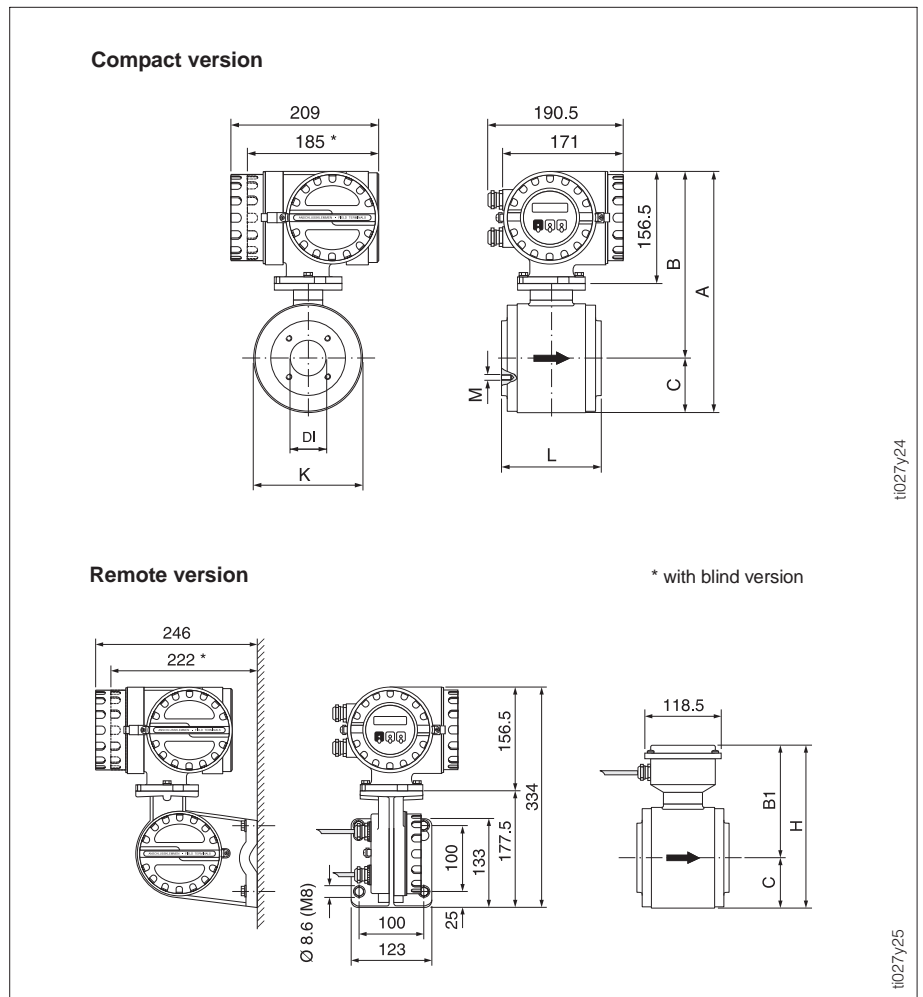

t1027y24

t1027y25

DN	DI ¹⁾	PN	L	A	B	B1	C	K	H	M	Weight ²⁾	
[mm]	[inch]	[mm]	[mm]	[mm]	[mm]	[mm]	[mm]	[mm]	[mm]	[mm]	[kg]	
25 DIN	-	26.0	16	140	318	254.0	158.5	64.0	128	222.5	M 6x4	6.0
25	1"	22.6	16	140	318	254.0	158.5	64.0	128	222.5	M 6x4	6.0
40	1 1/2"	35.3	16	140	318	254.0	158.5	64.0	128	222.5	M 6x4	6.5
50	2"	48.1	16	140	343	266.5	171.0	76.5	153	247.5	M 8x4	9.0
65	2 1/2"	59.9	16	140	343	266.5	171.0	76.5	153	247.5	M 8x4	9.0
80	3"	72.6	16	200	393	291.5	196.0	101.5	203	297.5	M 12x4	19.0
100	4"	97.5	16	200	393	291.5	196.0	101.5	203	297.5	M 12x4	18.5

¹⁾ Internal diameter of tube

Weight:
 Compact version ²⁾ see table above
 Promag 33 transmitter 3 kg (5 kg for wall mounted version)
 Sensor connection housing approx. 1 kg

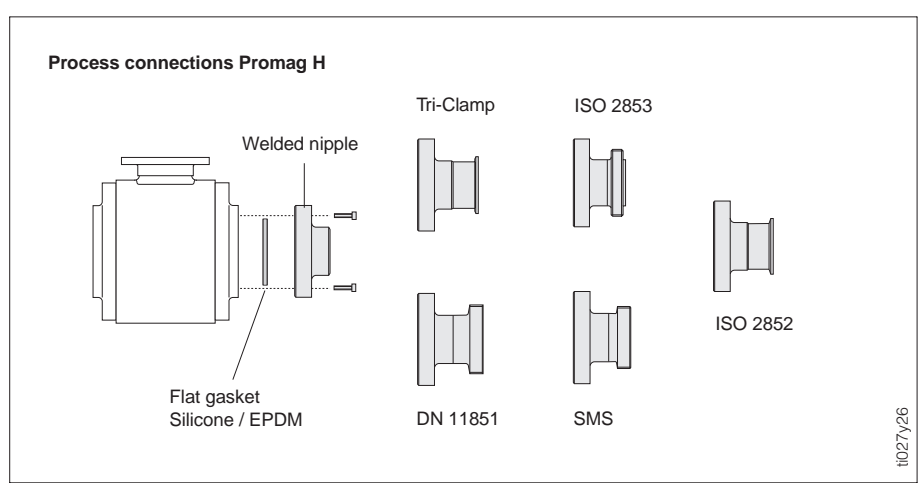

Process connections
Promag H
(Dimensions: see page 18)

t1027y26

Process Connections Promag H

Welded nipple

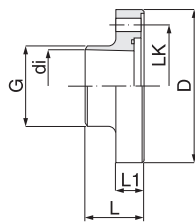

y27-01...06

DN	D	G	di ¹⁾	L	L1	LK
25	75	27	22.6	42	19	56.0
25 DIN	79	31	26.0	42	19	60.0
40	92	40	35.3	42	19	71.0
40 DIN	92	43	38.0	42	19	71.0
50	105	55	48.1	42	19	83.5
50 DIN	105	55	50.0	42	19	83.5
65	121	66	59.9	42	21	100.0
65 DIN	121	72	66.0	42	21	100.0
80	147	79	72.6	42	24	121.0
80 DIN	147	87	81.0	42	24	121.0
100	168	104	97.5	42	24	141.5
100 DIN	168	106	100.0	42	24	141.5

DIN 11851

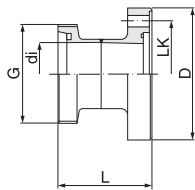

DN	di ¹⁾	G	D	L	LK
25	26	52 x 1/6"	79	68	60.0
40	38	65 x 1/6"	92	72	71.0
50	50	78 x 1/6"	105	74	83.5
65	66	95 x 1/6"	121	78	100.0
80	81	110 x 1/4"	147	83	121.0
100	100	130 x 1/4"	168	92	141.5

Tri-Clamp

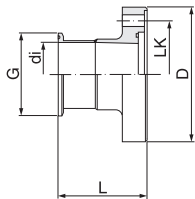

DN	ANSI	di ¹⁾	G	D	L	LK
25	1"	22.1	50.4	75	68.6	56.0
40	1 1/2"	34.8	50.4	92	68.6	71.0
50	2"	47.5	63.9	105	68.6	83.5
65	-	60.2	77.4	121	68.6	100.0
80	3"	72.9	90.9	147	68.6	121.0
100	4"	97.4	118.9	168	68.6	141.5

SMS 1145

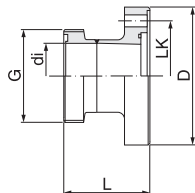

DN	di ¹⁾	G	D	L	LK
25	22.5	40 x 1/6"	75	60	56.0
40	35.5	60 x 1/6"	92	63	71.0
50	48.5	70 x 1/6"	105	65	83.5
65	60.5	85 x 1/6"	121	70	100.0
80	72.0	98 x 1/6"	147	75	121.0
100	97.6	132 x 1/6"	168	70	141.5

ISO 2852

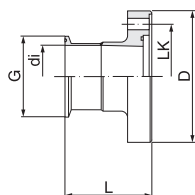

DN	di ¹⁾	G	D	L	LK
25	22.6	50.5	75	68.5	56.0
40	35.6	50.5	92	68.5	71.0
50	48.6	64.0	105	68.5	83.5
65	60.3	77.5	121	68.5	100.0
80	72.9	91.0	147	68.5	121.0
100	97.6	119.0	168	68.5	141.5

ISO 2853

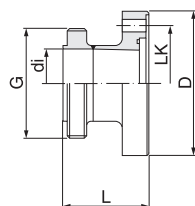

DN	di ¹⁾	G	D	L	LK
25	22.6	37.1	75	61.5	56.0
40	35.6	50.6	92	61.5	71.0
50	48.6	64.1	105	61.5	83.5
65	60.3	77.6	121	61.5	100.0
80	72.9	91.1	147	61.5	121.0
100	97.6	118.1	168	61.5	141.5

Length:
 DN 25... 65 = 2 x L + 136 mm
 DN 80...100 = 2 x L + 196 mm

¹⁾ Please note the internal diameter (di, DI) when cleaning the piping with a scraper!

Dimensions

Promag 33 F DN 15...300

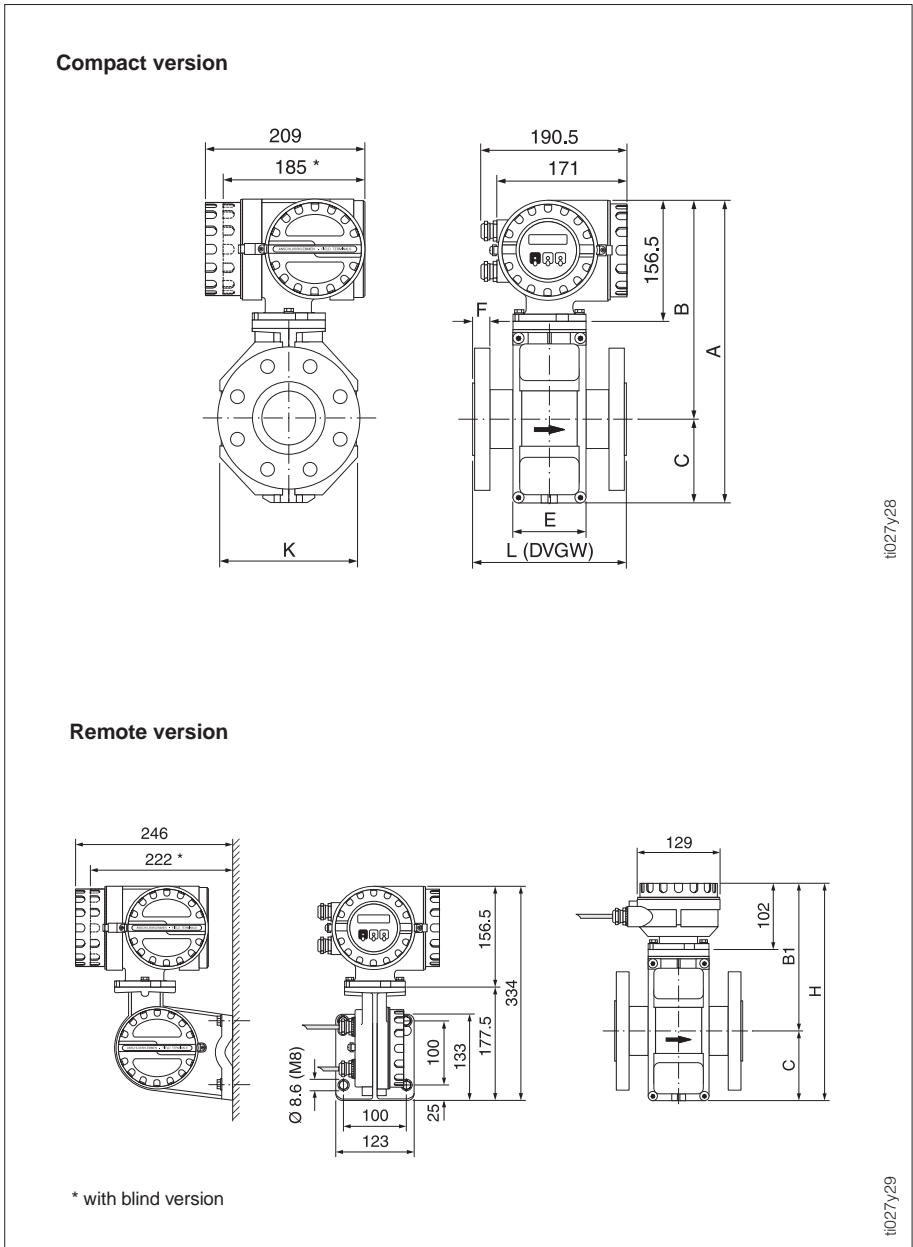

11027y28

11027y29

DN		DIN	PN		L ¹⁾	A	B	C	K	E	F		H	B1	Weight ²⁾
[mm]	[inch]		ANSI Class	JIS							DIN	ANSI [mm]			
15	1/2"	40	150	20K	200	340.5	256.5	84	120	94	14	11.2	286	202	6.5
25	1"	40	150	20K	200	340.5	256.5	84	120	94	16	14.2	286	202	7.3
32	-	40	-	20K	200	340.5	256.5	84	120	94	18	-	286	202	8.0
40	1 1/2"	40	150	20K	200	340.5	256.5	84	120	94	18	17.5	286	202	9.4
50	2"	40	150	10K	200	340.5	256.5	84	120	94	20	19.1	286	202	10.6
65	-	16	-	10K	200	390.5	281.5	109	180	94	18	-	336	227	12.0
80	3"	16	150	10K	200	390.5	281.5	109	180	94	20	23.9	336	227	14.0
100	4"	16	150	10K	250	390.5	281.5	109	180	94	22	23.9	336	227	16.0
125	-	16	-	10K	250	471.5	321.5	150	260	140	24	-	417	267	21.5
150	6"	16	150	10K	300	471.5	321.5	150	260	140	24	25.4	417	267	25.5
200	8"	10	150	10K	350	526.5	346.5	180	324	156	26	28.4	472	292	35.3
250	10"	10	150	10K	450	576.5	371.5	205	400	156	28	30.2	522	317	48.5
300	12"	10	150	10K	500	626.5	396.5	230	460	166	28	31.8	572	342	57.5

¹⁾ The length is always identical independently of the chosen pressure rating.

Weight:
 Compact version ²⁾ see table above
 Promag 33 transmitter 3 kg (5 kg for wall mounted version)
 Sensor connection housing approx. 1 kg

Dimensions

Promag 33 F DN 350...2000

Compact version

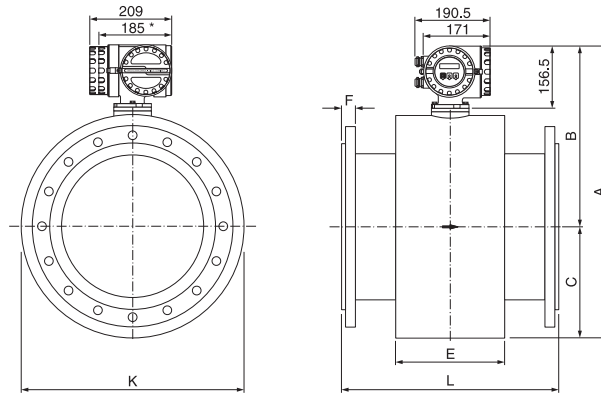

t1027y30

Remote version

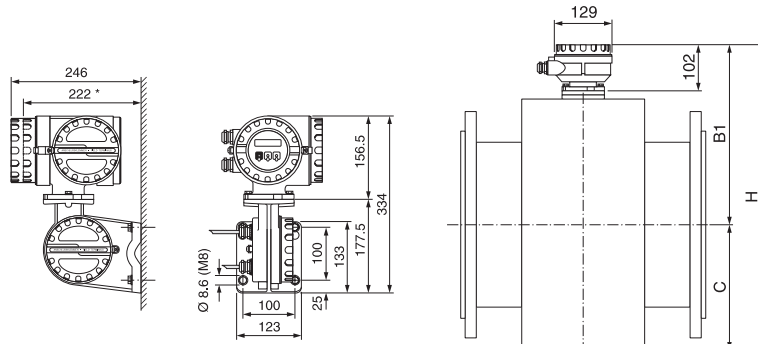

t1027y31

* with blind version

DN		PN			L ¹⁾	A	B	C	K	E	F			H	B1	Weight ²⁾	
[mm]	[inch]	DIN [bar]	ANSI [Class]	AWWA [Class]	[mm]	[mm]	[mm]	[mm]	[mm]	[mm]	DIN [mm]	ANSI [mm]	AWWA [mm]	[mm]	[mm]	[kg]	
350	14"	10	150	-	550	738	456.0	282.0	564	276	26	34.9	-	683.5	401.5	110	
400	16"	10	150	-	600	790	482.0	308.0	616	276	26	36.5	-	735.5	427.5	130	
450	18"	-	150	-	650	840	507.0	333.0	666	292	-	39.7	-	785.5	452.5	240	
500	20"	10	150	-	650	891	532.5	358.5	717	292	28	42.9	-	836.5	478.0	170	
600	24"	10	150	-	780	995	584.5	410.5	821	402	28	47.6	-	940.5	530.0	230	
700	28"	10	-	D	910	1198	686.0	512.0	1024	589	30	-	33.3	1143.5	631.5	350	
750	30"	-	-	D	975	1198	686.0	512.0	1024	626	-	-	34.9	1143.5	631.5	450	
800	32"	10	-	D	1040	1241	707.5	533.5	1067	647	32	-	38.1	1186.5	653.0	450	
900	36"	10	-	D	1170	1394	784.0	610.0	1220	785	34	-	41.3	1339.5	729.5	600	
1000	40"	10	-	D	1300	1546	860.0	686.0	1372	862	34	-	41.3	1491.5	805.5	720	
1050	42"	-	-	D	1365	1598	886.0	712.0	1424	912	-	-	44.5	1543.5	831.5	1050	
1200	48"	6	-	D	1560	1796	985.0	811.0	1622	992	28	-	44.5	1741.5	930.5	1200	
1350	54"	-	-	D	1755	1998	1086.0	912.0	1824	1252	-	-	54.0	1943.5	1031.5	2150	
1400	-	6	-	-	1820	2148	1161.0	987.0	1974	1252	32	-	-	2093.5	1106.5	1800	
1500	60"	-	-	D	1950	2196	1185.0	1011.0	2022	1392	-	-	57.2	2141.5	1130.5	2600	
1600	-	6	-	-	2080	2286	1230.0	1056.0	2112	1482	34	-	-	2231.5	1175.5	2500	
1650	66"	-	-	D	2145	2360	1267.0	1093.0	2186	1482	-	-	63.5	2305.5	1212.5	3700	
1800	72"	6	-	D	2340	2550	1362.0	1188.0	2376	1632	36	-	-	66.7	2495.5	1307.5	3300
2000	78"	6	-	D	2600	2650	1412.0	1238.0	2476	1732	38	-	-	69.9	2595.5	1357.5	4100

¹⁾ Thickness of the flange face includes sealing strip. The length is always identical independently of the chosen pressure rating.

Weight:

Compact version ²⁾ see table above
 Promag 33 transmitter 3 kg (5 kg for wall mounted version)
 Sensor connection housing approx. 1 kg

Material Load Curves (p-T-Diagrams)

Promag A

DIN 2413 and 2505

Flange material: Steel 1.4404/1.4435, PVDF, PVC

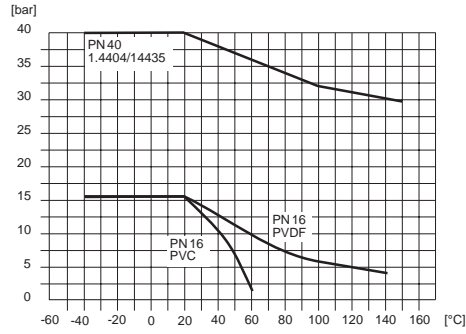

Promag H

Welded nipple material: Steel 1.4404/316L

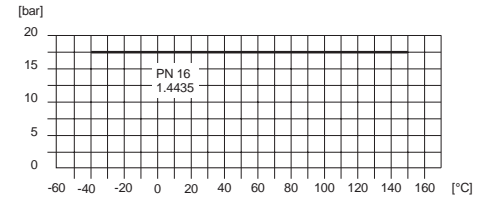

Promag F

DIN 2413 and 2505

Flange material: Steel 37.2

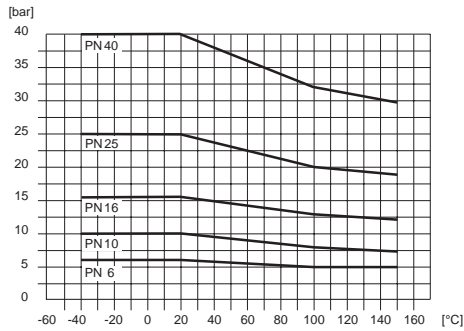

ANSI B16.5

Flange material: Steel A105

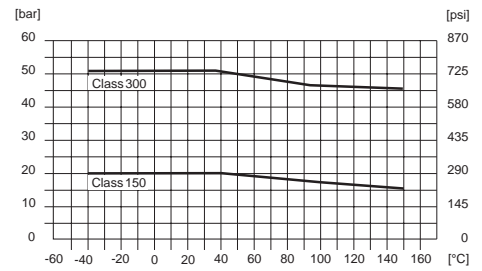

DIN 2413 and 2505

Flange material: Stainless steel 1.4571

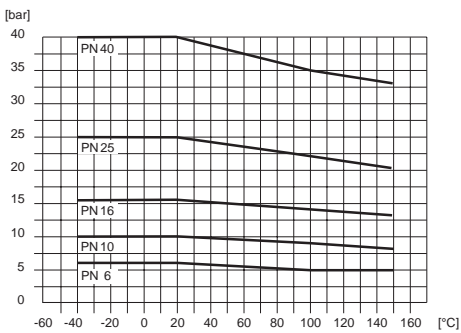

AWWA C 207, Class D

Flange material: Steel A105

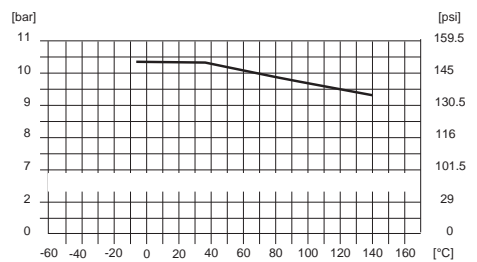

ANSI B16.5

Flange material: Steel 316L

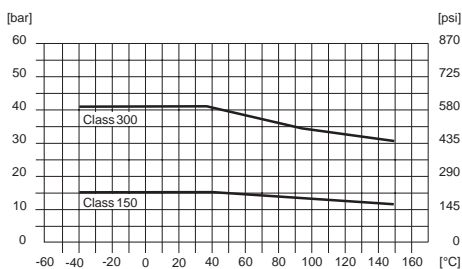

JIS B2210

Flange material: S20C / SUS 316L

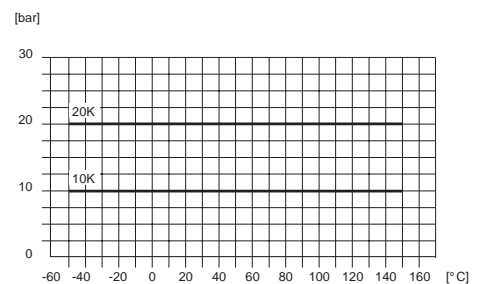

Technical Data

Application	
<i>Instrument name</i>	Flow measuring system "Promag 33"
<i>Instrument function</i>	Flow measurement of liquids in closed piping. Applications in measurement, control and regulation processes, for e.g. batching and dosing (> 10 s), etc.
Function and system design	
<i>Measuring principle</i>	Electromagnetic flow measurement according to Faraday's law (generation of a voltage by induction in a magnetic field).
<i>Measuring system</i>	Instrument family "Promag 33" consisting of: <ul style="list-style-type: none"> • Transmitter: Promag 33 (with electronics versions HART, PROFIBUS-PA, PROFIBUS-DP, Rackbus RS 485 or EEx i) • Sensor: Promag A (DN 2, 4, 8, 15, 25) Promag H (DN 25, 40, 50, 65, 80, 100) Promag F (DN 15...2000) <p>Two versions are available:</p> <ul style="list-style-type: none"> • Compact version • Remote version (FS or FL version)
Input variables	
<i>Measuring variable</i>	Flow velocity (proportional to induced voltage, measured by two electrodes in the measuring tube)
<i>Measuring range</i>	Measuring range of electronics within $v = 0 \dots 12.5$ m/s The full scale value for the current output can be selected within the following limits (see also page 5): – Minimum full scale value at $v = 0.3$ m/s – Maximum full scale value at $v = 10$ m/s
<i>Operable flow range</i>	Over 1000 : 1 When the flow is pulsating, the amplifier is not overloaded above its set full scale value even with peak velocities of 12.5 m/s. Flow is measured between 0.01...>10 m/s at the stated accuracy.
<i>Auxiliary input</i>	The auxiliary input is only available with a "RS 485" communications module. $U = 3 \dots 30$ V DC, $R_i = 1.8$ k Ω , galvanically isolated Configurable for: Positive zero return, totalizer reset, starting a batch cycle or dual range mode.
Output variables	
<i>Output signal</i>	<ul style="list-style-type: none"> • <i>Current output:</i> active, 0/4...20 mA, galvanically isolated, R_L (see page 23), time constant selectable (0.01...100 s), full scale value freely selectable, temperature coefficient: typical 0.005% o.r./$^{\circ}$C; resolution: 10 μA • <i>Pulse / frequency output:</i> active/passive selectable, galvanically isolated active: 24 V DC, 25 mA (max. 250 mA during 20 ms), $R_L > 100$ Ω passive: Open Collector, 30 V DC, 250 mA <p>Frequency output: full scale frequency 2...10000 Hz, pulse/pause ratio 1:1, pulse width max. 2 s</p> <p>Pulse output: pulse value and pulse polarity selectable, pulse width adjustable (0.05...2 s) above a frequency of 1 / (2 x pulse width) the pulse/pause ratio is 1:1</p> <p style="text-align: right;">(continued on next page)</p>

Output variables (continued)	
<i>Output signal (continued)</i>	<ul style="list-style-type: none"> • Alarm output (Relay 1): Either NC or NO via a jumper available (factory setting: NO contact) max. 60 V AC / 30 V DC; max. 0.5 A AC / 0.1 A DC, galvanically isolated. Configurable for: error message (failure), empty pipe detection (EPD), failure + EPD, full scale switching, batch precontact, direction of flow, limit value 1 and overflow ($v > 12.5$ m/s) • Status output (Relay 2): Either NC or NO via a jumper available (factory setting: NC contact) max. 60 V AC / 30 V DC; max. 0.5 A AC / 0.1 A DC, galvanically isolated. Configurable for: empty pipe detection (EPD), full scale switching, batch contact, direction of flow, limit value 2 and overflow ($v > 12.5$ m/s)
<i>Signal on alarm</i>	<ul style="list-style-type: none"> • Current output → failsafe mode selectable • Pulse/frequency output → failsafe mode selectable • Relay 1 output → de-energised on failure or power supply failure • Relay 2 output → de-energised on power supply failure
<i>Load (current output)</i>	$R_L < 700 \Omega$ (HART current output and Rackbus RS 485 version) $R_L < 350 \Omega$ (PROFIBUS-PA and EEx i version) $R_L \geq 250 \Omega$ (with HART)
<i>Creep suppression</i>	<ul style="list-style-type: none"> • Switching points selectable • Max. creepage depending on the nominal diameter at $v = 1$ m/s • Hysteresis: 50% of set creepage
Accuracy	
<i>Reference conditions</i>	<p>According to DIN 19200 and VDI/VDE 2641:</p> <p>Fluid temperature $+28 \text{ }^\circ\text{C} \pm 2 \text{ K}$ Ambient temperature $+22 \text{ }^\circ\text{C} \pm 2 \text{ K}$ Warm up period 30 minutes</p> <p><i>Mounting:</i></p> <ul style="list-style-type: none"> – Inlet section $> 10 \times \text{DN}$ – Outlet section $> 5 \times \text{DN}$ – Transmitter and sensor are grounded. – The sensor is build-in centered into the piping.
<i>Measured error</i>	<p>Pulse output: $\pm 0.5\%$ o.r. $\pm 0.01\%$ o.f.s. (full scale value = 10 m/s) Current output: additionally $\pm 5 \mu\text{A}$ (typical)</p> <p>o.r. = of reading o.f.s. = of max. full scale value</p> <div style="text-align: center;"> <p>Measured error [% o.r.]</p> <p>Legend: — 0.5% - - - 0.2% (Option)</p> <p>Fluid velocity [m/s]</p> </div> <p><i>Option:</i> Promag 33 A and F: $\pm 0.2\%$ o.r. $\pm 0.005\%$ of Q_k Q_k = desired reference flow quantity for calibration ($v = 2 \dots 10$ m/s). Q_k has to be noted for ordering.</p> <p>Deviations in power supply voltage have no influence on the specified ranges.</p>
<i>Repeatability</i>	$\pm 0.1\%$ o.r. $\pm 0.005\%$ o.f.s. o.r. = of reading o.f.s. = of max. full scale value (see table on page 5)

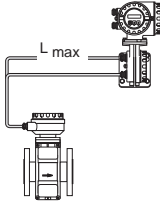
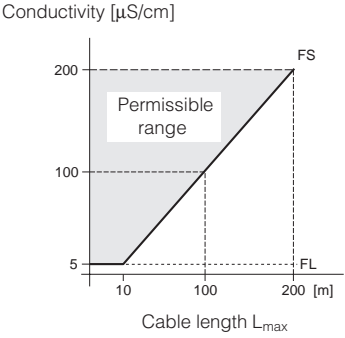
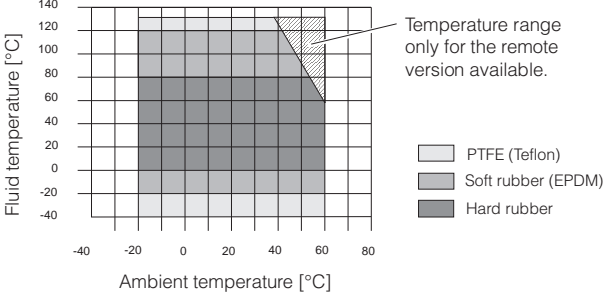
Operating conditions	
Installation conditions	
<i>Installation instructions</i>	Orientation: vertical or horizontal Restrictions and other recommendations → see page 6 ff.
<i>Inlet and outlet sections</i>	Inlet section: $\geq 5 \times \text{DN}$ Outlet section: $\geq 2 \times \text{DN}$
<i>Connection cable length</i>	<p><i>Remote FS version:</i> 0... 10 m → min. conductivity $\geq 5 \mu\text{S/cm}$ (for liquids in general) 0... 10 m → min. conductivity $\geq 20 \mu\text{S/cm}$ (for demineralised water) 10...200 m → min. conductivity = $f(L_{\text{max}})$</p> <p><i>Remote FL version:</i> 0...200 m → min. conductivity $\geq 5 \mu\text{S/cm}$ (for liquids in general) 0...200 m → min. conductivity $\geq 20 \mu\text{S/cm}$ (for demineralised water)</p> <p><i>Instrument equipped with empty pipe detection (EPD):</i> max. cable length = 10 m</p> <div style="text-align: center;">  </div> <div style="text-align: center;">  </div>
Ambient conditions	
<i>Ambient temperature</i>	<p>−25...+60 °C (Transmitter and sensor)</p> <ul style="list-style-type: none"> • An all-weather cover should be used to protect the housing from direct sunlight when mounting in the open. This is especially important in warmer climates and with high ambient temperatures. • Due to the danger of the transmitter electronics overheating, the transmitter and sensor are to be mounted separately with high ambient and fluid temperatures (see Figure). <div style="text-align: center;">  </div>
<i>Storage temperature</i>	−10...+50 °C (preferably at +20 °C)
<i>CIP cleanable</i>	Promag A, H, F → Yes (observe maximum temperature)

Operating conditions (continued)																																																								
Ambient conditions																																																								
<i>SIP cleanable</i>	Promag A → No Promag H → Yes (observe maximum temperature) Promag F → No																																																							
<i>Degree of protection (EN 60529)</i>	IP 67 (NEMA 4X) Option: IP 68 (NEMA 6P) for sensor A and F																																																							
<i>Shock and vibration resistance</i>	Accelleration up to 2 g / 2 h per day; 10...100 Hz																																																							
<i>Electromagnetic compatibility (EMC)</i>	According to EN 50081 Part 1 and 2 (interference emission) / EN 50082 Part 1 and 2 (interference immunity) as well as to NAMUR recommendations																																																							
Process conditions																																																								
<i>Fluid temperature</i>	The fluid temperature range depends on the sensor lining: <table border="0" style="width: 100%;"> <tr> <td style="width: 15%;"><i>Promag A</i></td> <td style="width: 30%;">-20...+130 °C</td> <td style="width: 15%;">PFA</td> <td style="width: 40%;"></td> </tr> <tr> <td rowspan="2"><i>Promag H</i></td> <td>-20...+130 °C</td> <td>PFA with EPDM gasket</td> <td></td> </tr> <tr> <td>-20...+150 °C</td> <td>PFA with Silicone gasket</td> <td></td> </tr> <tr> <td rowspan="3"><i>Promag F</i></td> <td>-40...+130 °C</td> <td>PTFE (Teflon), DN 15...600</td> <td></td> </tr> <tr> <td>-20...+120 °C</td> <td>Soft rubber (EPDM), DN 25...2000</td> <td></td> </tr> <tr> <td>0...+ 80 °C</td> <td>Hard rubber, DN 65...2000</td> <td>(see Fig. on page 24)</td> </tr> </table>	<i>Promag A</i>	-20...+130 °C	PFA		<i>Promag H</i>	-20...+130 °C	PFA with EPDM gasket		-20...+150 °C	PFA with Silicone gasket		<i>Promag F</i>	-40...+130 °C	PTFE (Teflon), DN 15...600		-20...+120 °C	Soft rubber (EPDM), DN 25...2000		0...+ 80 °C	Hard rubber, DN 65...2000	(see Fig. on page 24)																																		
<i>Promag A</i>	-20...+130 °C	PFA																																																						
<i>Promag H</i>	-20...+130 °C	PFA with EPDM gasket																																																						
	-20...+150 °C	PFA with Silicone gasket																																																						
<i>Promag F</i>	-40...+130 °C	PTFE (Teflon), DN 15...600																																																						
	-20...+120 °C	Soft rubber (EPDM), DN 25...2000																																																						
	0...+ 80 °C	Hard rubber, DN 65...2000	(see Fig. on page 24)																																																					
<i>Nominal pressure</i>	<table border="0" style="width: 100%;"> <tr> <td style="width: 15%;"><i>Promag A</i></td> <td style="width: 15%;">PN 16</td> <td style="width: 15%;">for Tri-Clamp, PVC couplings</td> <td style="width: 55%;">for all other connections</td> </tr> <tr> <td></td> <td>PN 40</td> <td></td> <td></td> </tr> <tr> <td><i>Promag H</i></td> <td>PN 16</td> <td></td> <td></td> </tr> <tr> <td rowspan="5"><i>Promag F</i></td> <td rowspan="4">DIN</td> <td>PN 6</td> <td>(DN 1200...2000)</td> </tr> <tr> <td>PN 10</td> <td>(DN 200...1000)</td> </tr> <tr> <td>PN 16</td> <td>(DN 65...150)</td> </tr> <tr> <td>PN 40</td> <td>(DN 15...50)</td> </tr> <tr> <td></td> <td>PN 10</td> <td>(DN 1200...2000, optional)</td> </tr> <tr> <td></td> <td>PN 16/25</td> <td>(DN 200...1000, optional)</td> <td></td> </tr> <tr> <td></td> <td>PN 40</td> <td>(DN 65...150, optional)</td> <td></td> </tr> <tr> <td></td> <td>ANSI</td> <td>Class 150 (1/2...24")</td> <td></td> </tr> <tr> <td></td> <td></td> <td>Class 300 (1/2...6", optional)</td> <td></td> </tr> <tr> <td></td> <td>AWWA</td> <td>Class D (28...48")</td> <td></td> </tr> <tr> <td></td> <td rowspan="3">JIS</td> <td>10K (DN 50...300)</td> <td></td> </tr> <tr> <td></td> <td>20K (DN 15...40)</td> <td></td> </tr> <tr> <td></td> <td>20K (DN 50...300, optional)</td> <td></td> </tr> </table> <p>Material load curves (p-T-load diagrams) → see page 21</p>	<i>Promag A</i>	PN 16	for Tri-Clamp, PVC couplings	for all other connections		PN 40			<i>Promag H</i>	PN 16			<i>Promag F</i>	DIN	PN 6	(DN 1200...2000)	PN 10	(DN 200...1000)	PN 16	(DN 65...150)	PN 40	(DN 15...50)		PN 10	(DN 1200...2000, optional)		PN 16/25	(DN 200...1000, optional)			PN 40	(DN 65...150, optional)			ANSI	Class 150 (1/2...24")				Class 300 (1/2...6", optional)			AWWA	Class D (28...48")			JIS	10K (DN 50...300)			20K (DN 15...40)			20K (DN 50...300, optional)	
<i>Promag A</i>	PN 16	for Tri-Clamp, PVC couplings	for all other connections																																																					
	PN 40																																																							
<i>Promag H</i>	PN 16																																																							
<i>Promag F</i>	DIN	PN 6	(DN 1200...2000)																																																					
		PN 10	(DN 200...1000)																																																					
		PN 16	(DN 65...150)																																																					
		PN 40	(DN 15...50)																																																					
		PN 10	(DN 1200...2000, optional)																																																					
	PN 16/25	(DN 200...1000, optional)																																																						
	PN 40	(DN 65...150, optional)																																																						
	ANSI	Class 150 (1/2...24")																																																						
		Class 300 (1/2...6", optional)																																																						
	AWWA	Class D (28...48")																																																						
	JIS	10K (DN 50...300)																																																						
		20K (DN 15...40)																																																						
		20K (DN 50...300, optional)																																																						
<i>Conductivity</i>	<p>Minimum conductivity: ≥ 5 µS/cm → for liquids in general ≥ 20 µS/cm → for demineralised water</p> <p>With the remote "FS" version the conductivity required also depends on the length of the cable → see page 24 "Connection cable length"</p>																																																							
<i>Pressure loss</i>	<ul style="list-style-type: none"> • No pressure loss if sensor and piping have the same nominal diameter. • Pressure loss specifications when using adapters e.g. reducers or expanders → see page 8 																																																							

Technical Data

Mechanical construction	
<i>Design / Dimensions</i>	Dimensions → see pages 15–20
<i>Weight</i>	See pages 15–20
<i>Materials</i>	<p><i>Transmitter housing:</i> Powder-coated die-cast aluminium</p> <p><i>Sensor housing:</i> Promag A 1.4435 incl. threaded stub Promag H 1.4301 Promag F DN 15...300: Powder-coated die-cast aluminium DN 350...2000: Coated steel</p> <p><i>Process connections:</i> Promag A DIN → Stainless steel 1.4404, PVDF ANSI → 316L, PVDF JIS → 316L, PVDF Threaded stub: 1.4435, PVC Promag H 1.4404 / 316L Promag F DIN → Stainless steel 1.4571, St. 37-2 ANSI → A 105, 316L AWWA → A 105, A 36 JIS → S20C, SUS 316L</p> <p><i>Electrodes:</i> Promag A 1.4435; Platinum/Rhodium 80/20; Titanium; Hastelloy C-22; Tantalum Promag H 1.4435 Promag F 1.4435; Platinum/Rhodium 80/20; Hastelloy C-22; Tantalum</p> <p><i>Gasket material:</i> Promag A Viton, Kalrez (optional), Silicone (aseptic version) Promag H EPDM, Silicone Promag F no gaskets (lining = 'gasket')</p>
<i>Electrodes fitted</i>	<p>Promag A Measuring, reference and empty pipe detection electrodes. As standard with: 1.4435, Hastelloy C-22, Tantalum Option with: Platinum/Rhodium</p> <p>Promag H Measuring and empty pipe detection electrodes</p> <p>Promag F Measuring, reference and empty pipe detection electrodes. As standard with: 1.4435, Hastelloy C-22, Tantalum</p>
<i>Process connections</i>	<p><i>Promag A:</i> Internal and external thread, PVC adhesive coupling, hose connection, welded nipple, aseptic welded nipples for pipelines according to DIN 11850, Tri-Clamp, flange connection (DIN, ANSI, JIS).</p> <p><i>Promag H:</i> Welded nipples for OD tube, SMS, JIS, ISO and DIN 11850 tubes, DIN 11851 thread, SMS thread, ISO 2853 thread, Tri-Clamp, ISO 2852 connection.</p> <p><i>Promag F:</i> Flange connection (DIN, ANSI, JIS)</p>
<i>Electrical connection</i>	<ul style="list-style-type: none"> • Wiring diagrams: see page 9 ff. • Cable specifications: see page 12 • Galvanic isolation: All circuits for inputs, outputs, power supply and sensors are galvanically isolated from one another.
<i>Cable entries</i>	<p><i>Power supply and signal cable (outputs):</i> Cable glands PG 13.5 (5...15 mm) or threads for cable glands 1/2" NPT, M20 x 1.5 (8...15 mm), G 1/2"</p> <p><i>Coil current cable and signal cable (remote version)</i> Promag A: Cable glands PG 11 (5...12 mm) or threads for cable glands 1/2" NPT, M20 x 1.5 (8...15 mm), G 1/2" Promag H: Cable glands PG 13.5 (5...15 mm) or threads for cable glands 1/2" NPT, M20 x 1.5 (8...15 mm), G 1/2" Promag F: Cable glands PG 13.5 (5...15 mm) or threads for cable glands 1/2" NPT, M20 x 1.5 (8...15 mm), G 1/2"</p>

User interface	
<i>Operation</i>	<ul style="list-style-type: none"> • On-site operation with three optical keypads (E, -, +) • E+H operating matrix for all instrument functions
<i>Display</i>	<ul style="list-style-type: none"> • LC display: illuminated, double-spaced with 16 characters each • Damping of flow display can be adjusted: 0...99 s
<i>Communication</i>	<ul style="list-style-type: none"> • SMART protocol (HART protocol via current output) • PROFIBUS-PA / PROFIBUS-DP • Rackbus RS 485 interface (Rackbus protocol)
Power supply	
<i>Supply voltage / Frequency</i>	85...260 V AC, 45...65 Hz 20... 55 V AC, 45...65 Hz 16... 62 V DC
<i>Power consumption</i>	AC: <15 VA (incl. sensor) DC: <15 W (incl. sensor) Current at make (Promag 33 X / 24 V DC): – max. 13.5 A (< 100 µs) – max. 6 A (< 5 ms)
<i>Power supply failure</i>	Bridges minimum 1 power cycle (22 ms) <ul style="list-style-type: none"> • EEPROM saves measuring system data on power failure (no batteries required). • DAT = replaceable data memory in which basic data of the sensor are stored: nominal diameter, SAPS (actual values), serial number, calibration factor, zero point, status EPD (yes/no), EPD calibration values.
Certificates and approvals	
<i>Ex approvals</i>	Information on Ex versions (e.g. ATEX/CENELEC, FM, CSA) can be supplied by your E+H sales center on request. All explosion protection data are given in separate documentation available on request.
<i>Sanitary version</i>	<ul style="list-style-type: none"> • Sensor Promag A: 3A approval • Sensor Promag H (hygienic version): 3A approval and EHEDG tested
<i>CE mark</i>	By attaching the CE mark confirms that the Promag 33 measurement system has been successfully tested and fulfils all legal requirements of the relevant CE directives.
Order information	
<i>Accessories</i>	<ul style="list-style-type: none"> • Post mounting set for transmitter (remote version): Order No. 50076905 • Wall mounting kit for Promag A sensor: Order No. 50064550
<i>Supplementary documentation</i>	System Information Promag (SI 010D/06/en) Operating Manual Promag 33 (BA 009D/06/en) Supplementary Ex documentation: ATEX/CENELEC, FM, CSA
Other standards and guidelines	
EN 60529	Degree of protection by housing (IP code)
EN 61010	Protection Measures for Electronic Equipment for Measurement, Control, Regulation and Laboratory Procedures
EN 50081	Part 1 and 2 (interference emission)
EN 50082	Part 1 and 2 (interference immunity)
NAMUR	Association of Standards for Control and Regulation in the Chemical Industry

По вопросам продаж и поддержки обращайтесь:

Алматы (7273)495-231
Ангарск (3955)60-70-56
Архангельск (8182)63-90-72
Астрахань (8512)99-46-04
Барнаул (3852)73-04-60
Белгород (4722)40-23-64
Благовещенск (4162)22-76-07
Брянск (4832)59-03-52
Владивосток (423)249-28-31
Владикавказ (8672)28-90-48
Владимир (4922)49-43-18
Волгоград (844)278-03-48
Вологда (8172)26-41-59
Воронеж (473)204-51-73
Екатеринбург (343)384-55-89

Иваново (4932)77-34-06
Ижевск (3412)26-03-58
Иркутск (395)279-98-46
Казань (843)206-01-48
Калининград (4012)72-03-81
Калуга (4842)92-23-67
Кемерово (3842)65-04-62
Киров (8332)68-02-04
Коломна (4966)23-41-49
Кострома (4942)77-07-48
Краснодар (861)203-40-90
Красноярск (391)204-63-61
Курск (4712)77-13-04
Курган (3522)50-90-47
Липецк (4742)52-20-81

Магнитогорск (3519)55-03-13
Москва (495)268-04-70
Мурманск (8152)59-64-93
Набережные Челны (8552)20-53-41
Нижний Новгород (831)429-08-12
Новокузнецк (3843)20-46-81
Ноябрьск (3496)41-32-12
Новосибирск (383)227-86-73
Омск (3812)21-46-40
Орел (4862)44-53-42
Оренбург (3532)37-68-04
Пенза (8412)22-31-16
Петрозаводск (8142)55-98-37
Псков (8112)59-10-37
Пермь (342)205-81-47

Ростов-на-Дону (863)308-18-15
Рязань (4912)46-61-64
Самара (846)206-03-16
Санкт-Петербург (812)309-46-40
Саратов (845)249-38-78
Севастополь (8692)22-31-93
Саранск (8342)22-96-24
Симферополь (3652)67-13-56
Смоленск (4812)29-41-54
Сочи (862)225-72-31
Ставрополь (8652)20-65-13
Сургут (3462)77-98-35
Сыктывкар (8212)25-95-17
Тамбов (4752)50-40-97
Тверь (4822)63-31-35

Тольятти (8482)63-91-07
Томск (3822)98-41-53
Тула (4872)33-79-87
Тюмень (3452)66-21-18
Ульяновск (8422)24-23-59
Улан-Удэ (3012)59-97-51
Уфа (347)229-48-12
Хабаровск (4212)92-98-04
Чебоксары (8352)28-53-07
Челябинск (351)202-03-61
Череповец (8202)49-02-64
Чита (3022)38-34-83
Якутск (4112)23-90-97
Ярославль (4852)69-52-93

Россия +7(495)268-04-70

Казахстан +7(7172)727-132

Киргизия +996(312)96-26-47

эл.почта: ehr@nt-rt.ru || сайт: <https://endcounters.nt-rt.ru/>