

Уровнемеры

prosonic T FMU230, FMU231

Технические характеристики

По вопросам продаж и поддержки обращайтесь:

Алматы (7273)495-231
Ангарск (3955)60-70-56
Архангельск (8182)63-90-72
Астрахань (8512)99-46-04
Барнаул (3852)73-04-60
Белгород (4722)40-23-64
Благовещенск (4162)22-76-07
Брянск (4832)59-03-52
Владивосток (423)249-28-31
Владикавказ (8672)28-90-48
Владимир (4922)49-43-18
Волгоград (844)278-03-48
Вологда (8172)26-41-59
Воронеж (473)204-51-73
Екатеринбург (343)384-55-89

Иваново (4932)77-34-06
Ижевск (3412)26-03-58
Иркутск (395)279-98-46
Казань (843)206-01-48
Калининград (4012)72-03-81
Калуга (4842)92-23-67
Кемерово (3842)65-04-62
Киров (8332)68-02-04
Коломна (4966)23-41-49
Кострома (4942)77-07-48
Краснодар (861)203-40-90
Красноярск (391)204-63-61
Курск (4712)77-13-04
Курган (3522)50-90-47
Липецк (4742)52-20-81

Магнитогорск (3519)55-03-13
Москва (495)268-04-70
Мурманск (8152)59-64-93
Набережные Челны (8552)20-53-41
Новокузнецк (3843)20-46-81
Ноябрьск (3496)41-32-12
Новосибирск (383)227-86-73
Омск (3812)21-46-40
Орел (4862)44-53-42
Оренбург (3532)37-68-04
Пенза (8412)22-31-16
Петрозаводск (8142)55-98-37
Псков (8112)59-10-37
Пермь (342)205-81-47

Ростов-на-Дону (863)308-18-15
Рязань (4912)46-61-64
Самара (846)206-03-16
Санкт-Петербург (812)309-46-40
Саратов (845)249-38-78
Севастополь (8692)22-31-93
Саранск (8342)22-96-24
Симферополь (3652)67-13-56
Смоленск (4812)29-41-54
Сочи (862)225-72-31
Ставрополь (8652)20-65-13
Сургут (3462)77-98-35
Сыктывкар (8212)25-95-17
Тамбов (4752)50-40-97
Тверь (4822)63-31-35

Тольятти (8482)63-91-07
Томск (3822)98-41-53
Тула (4872)33-79-87
Тюмень (3452)66-21-18
Ульяновск (8422)24-23-59
Улан-Удэ (3012)59-97-51
Уфа (347)229-48-12
Хабаровск (4212)92-98-04
Чебоксары (8352)28-53-07
Челябинск (351)202-03-61
Череповец (8202)49-02-64
Чита (3022)38-34-83
Якутск (4112)23-90-97
Ярославль (4852)69-52-93

Россия +7(495)268-04-70

Казахстан +7(7172)727-132

Киргизия +996(312)96-26-47

эл.почта: ehr@nt-rt.ru || сайт: <https://endcounters.nt-rt.ru/>



Level



Pressure



Flow



Temperature



Liquid
Analysis



Registration



Systems
Components



Services



Solutions

Technical Information

prosonic T FMU230, FMU231

Ultrasonic Level Measurement

Compact transmitters for non-contact level measurement of fluids and coarse bulk materials



Application

The compact transmitters Prosonic T are used for continuous, non-contact level measurement in fluids and coarse bulk and lumpy materials (grain size from 4 mm onwards).

The maximum measuring range is

- FMU 230:
 - 4 m in fluids
 - 2 m in bulk materials
- FMU 231:
 - 7 m in fluids
 - 3,5 m in bulk materials

Your benefits

- Non-contact measurement method, therefore almost independent of product properties
- Integrated temperature sensor for time-of-flight correction. Accurate measurements, even for temperature changes
- Linearisation function for measured value output in any units
- with optional display
- simple mounting via G1½", G2", NPT 1½" or NPT 2" thread
- Two-wire instrument; level indicated by 4-20 mA output current

Table of Contents

Function and system design	3	Human interface	10
Time-of-flight method	3	Operating elements	10
Signal evaluation	3	LED	10
Calibration	3	Display module	
Linearisation	3	(optional)	10
Input	4	Certificates and Approvals	10
Measured variable	4	CE mark	10
Measuring range	4	External standards and guidelines	10
Operating frequency	5	Ordering information	11
Output	5	Product structure	11
Output signal	5	Scope of delivery	11
Signal on alarm	5	Accessories	11
Output damping	5	Protective cover	11
Load	6	Adapter flange	12
Auxiliary energy	6	Mounting bracket	12
Electrical connection	6	Cantilever	13
Supply voltage	6	Mounting bracket	14
Power consumption	6	Wall bracket for cantilever	14
Cable entry	6	Supplementary documentation	15
Performance characteristics	6	System-Information	15
Reference operating conditions	6	Operating manual	15
Measured value resolution	6		
Measuring error	6		
Pulse frequency	6		
Reaction time	6		
Installation conditions	7		
Installation variants	7		
Blocking distance, nozzle mounting	7		
Installation position	8		
Ambient conditions	8		
Ambient temperature	8		
Storage temperature	8		
Climate class	8		
Ingress protection	8		
Vibration resistance	8		
Electromagnetic compatibility (EMC)	8		
Process conditions	9		
Process temperature	9		
Process pressure	9		
Mechanical construction	9		
Design / Dimensions	9		
Weight	9		
Housing material	9		
Process connection	9		

Function and system design

Time-of-flight method

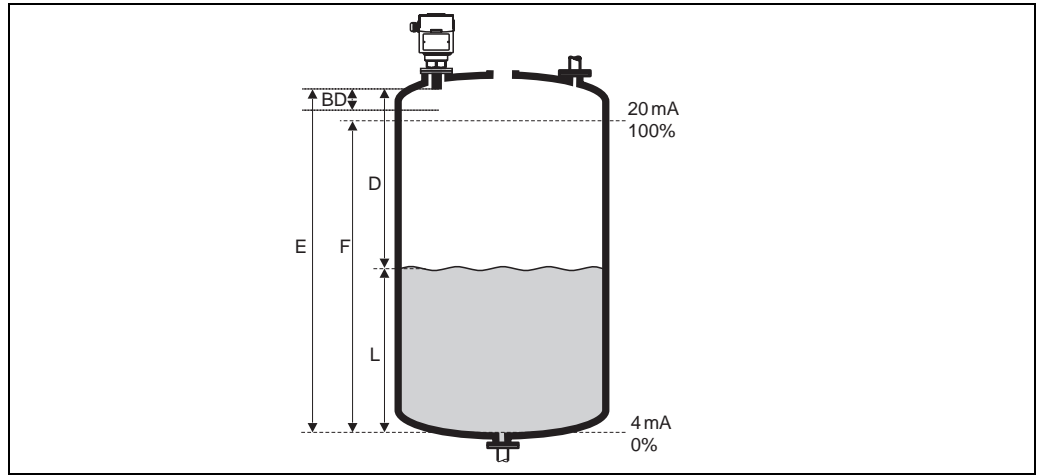

E: Empty distance; **F:** Span (full distance); **D:** Distance from sensor membrane - product surface; **L:** Level; **BD:** Blocking distance

The sensor of the Prosonic T transmits ultrasonic pulses in the direction of the product surface. There, they are reflected back and received by the sensor. The Prosonic T measures the time t between pulse transmission and reception. The instrument uses the time t (and the velocity of sound c) to calculate the distance D between the sensor membrane and the product surface:

$$D = c \cdot t / 2$$

As the device knows the empty distance E from a user entry, it can calculate the level as follows:

$$L = E - D$$

An integrated temperature sensor compensates for changes in the velocity of sound caused by temperature changes.

Signal evaluation

- Automatic suppression of up to 3 interference echoes (fixed target echoes)
- First echo detection

Calibration

Calibration is performed by entering the empty distance E (=zero) and the full distance F (= span).

E and F correspond to

- 4 mA or 20 mA respectively for the current output
- 0% or 100% respectively for the local display

Span F may not extend into the blocking distance BD . Level echos from the blocking distance cannot be evaluated due to the transient characteristics of the sensor and a wrong measured value may result.

For the version with on-site display, E and F can be entered directly as numbers. For the version without display, calibration can be performed for example by filling the vessel to the E and F point consecutively.

Linearisation

The linearisation function of the Prosonic T allows conversion of the measured value into any unit of length or volume. A linearisation table consisting of up to 11 value pairs can be entered manually or semi-automatically (by filling the vessel under controlled conditions).

Input

Measured variable

The distance D between the sensor membrane and the product surface is measured .

Using the linearisation function, the device uses D to calculate:

- level L in any units
 - volume V in any units
-

Measuring range

Upper limit: blocking distance

Instrument	blocking distance (BD)
FMU 230	0,25 m
FMU 231	0,4 m

The upper limit of the measuring distance is given by the blocking distance (page 2). Level echos within the blocking distance cannot be evaluated due to the transient characteristics of the sensor.

Lower limit: Range of the sensor

The measuring range is limited by the range of a sensor. The sensor range is, in turn, dependent on the operating conditions. To estimate the actual range, proceed as follows (see also the calculation example in the diagram):

1. Determine which of the influences shown in the following table are appropriate for your process.
2. Add the corresponding attenuation values.
3. From the total attenuation, use the diagram to calculate the range.

Fluid surface	Attenuation
Calm	0 dB
Waves	5 ... 10 dB
Strong turbulence	10 ... 20 dB
Foaming	Ask E+H

Bulk material surface	Attenuation
Hard, rough (e.g. rubble)	40 dB
Soft (e.g. peat, dust-covered clinker)	40 ... 60 dB

Dust	Attenuation
No dust formation	0 dB
Little dust formation	5 dB
Heavy dust formation	5 ... 20 dB

Filling curtain in detection range	Attenuation
None	0 dB
Small quantities	5 ... 10 dB
Large quantities	10 ... 40 dB

Temperature difference between sensor and product surface	Attenuation
to 20 °C	0 dB

Temperature difference between sensor and product surface	Attenuation
to 40 °C	5 ... 10 dB
to 80 °C	10 ... 20 dB

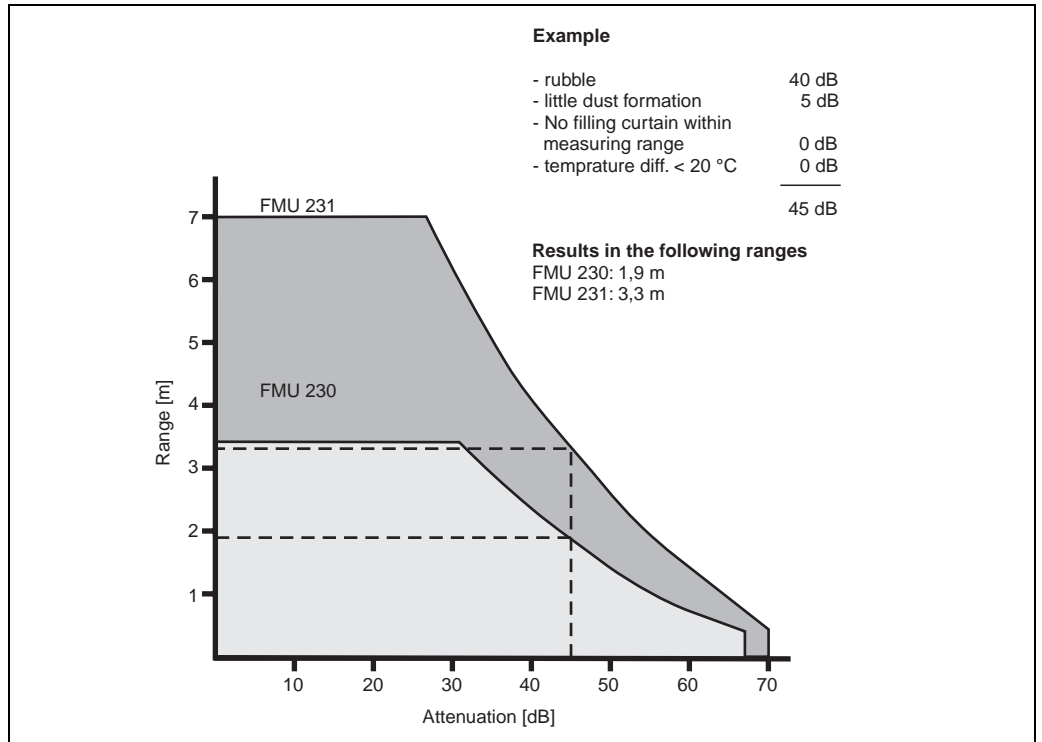

L00-FMU23xxx-05-00-00-en-001

Operating frequency

Instrument	Operating frequency
FMU 230	approx. 70 kHz
FMU 231	approx. 50 kHz

Output

Output signal 4 ... 20 mA analog signal

Signal on alarm configurable:

- 3,8 mA
- 22 mA
- hold last value

Output damping 0 ... 255 s

Load

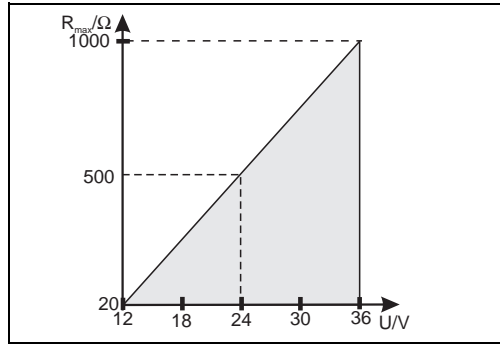

The maximum load (R_{\max}) depends on the supply voltage (U).

Auxiliary energy

Electrical connection

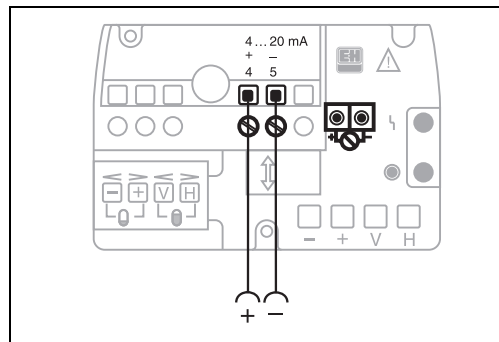

Use screened two-core instrumentation cable. For optimal protection against electromagnetic interference, the screen should be grounded in the control room or the nearest earthing point. A good connection to ground is essential to good screening.

Supply voltage

12 ... 36 V_{DC}

Power consumption

< 0,8 W

Cable entry

- Cable gland M20x1,5
 - Cable entry G ½ or ½ NPT
- cable diameter 5 ... 9 mm

Performance characteristics

Reference operating conditions

The specified performance characteristics are valid under the following reference conditions:

- Temperature = +20 °C
- Pressure = 1013 mbar abs.
- Humidity = 60 %
- Ideal reflective surface (e.g. calm, smooth fluid surface)
- No interference reflections within signal beam

Measured value resolution

3 mm

Measuring error

0,25% of maximum measuring range (includes linearity, repeatability, and hysteresis)

Pulse frequency

0,5 ... 1 Hz

Reaction time

approx. 5 s

Installation conditions

Installation variants

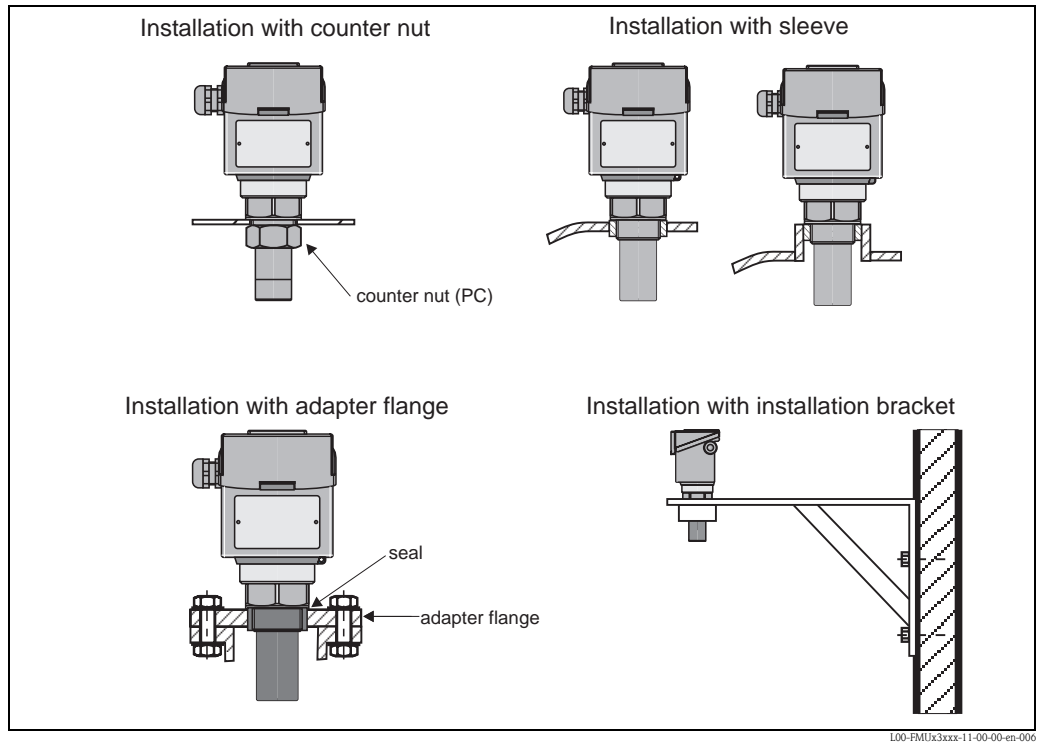

Blocking distance, nozzle mounting

Level echos from the blocking distance (BD) cannot be evaluated due to the transient characteristics of the sensor. Install the Prosonic T at a height so that the blocking distance BD is not undershot, even at maximum fill level. Use a pipe nozzle if you cannot maintain the blocking distance in any other way. The interior of the nozzle must be smooth and may not contain any edges or welded joints. In particular, there should be no burr on the inside of the tank side nozzle end. Note the specified limits for nozzle diameter and length.

FMU 230 with Display	
D [mm]	max.L [mm]
50	80
80	240
100	300

FMU 231 with Display	
D [mm]	max.L [mm]
80	240
100	300

FMU 230/231 without Display:
 Dmin = 100 mm
 Lmax = 150 mm

L00-FMUhc3xxx-11-00-00-de-007



Caution!
If the blocking distance is undershot, it may cause device malfunction.

Installation position

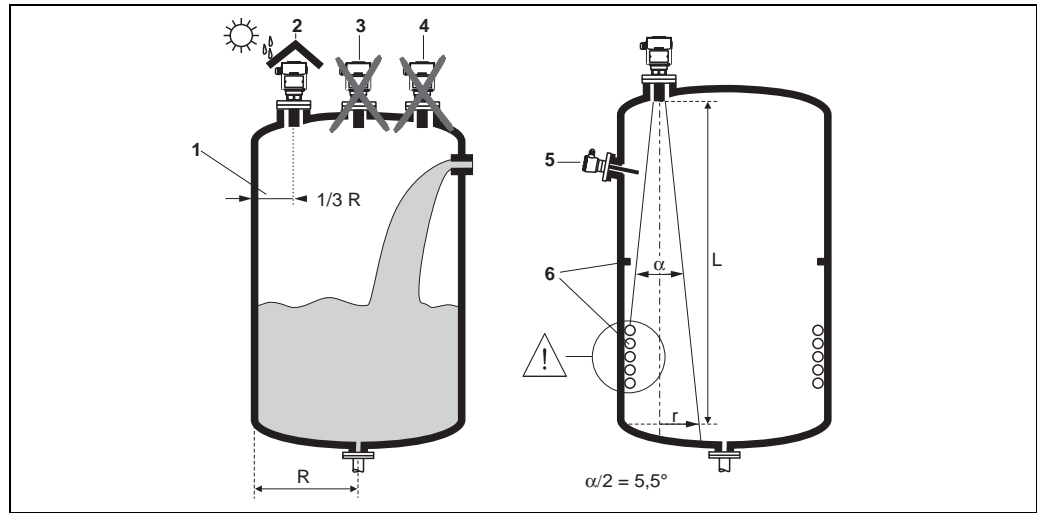

- Do not install the sensor in the middle of the tank (3). We recommend leaving a distance between the sensor and the tank wall (1) measuring $1/3$ of the tank radius.
- Use a protective cover, in order to protect the device from direct sun or rain (2).
- Avoid measurements through the filling curtain (4).
- Make sure that equipment (5) such as limit switches, temperature sensors, etc. are not located within the emitting angle α . In particular, symmetrical equipment (6) such as heating coils, baffles etc. can influence measurement.
- Align the sensor so that it is vertical to the product surface.
- Never install two identical ultrasonic measuring devices in a tank.
- To estimate the transmitted echo beam and its detection range, use the 3 dB emitting angle α :

Sensor	α	L	r
FMU 230	11°	4 m	0,38 m
FMU 231	11°	7 m	0,67 m

Ambient conditions

Ambient temperature -20 °C ... +60 °C

Storage temperature -40°C ... +80°C

Climate class DIN/IEC 68 T2-30Db

Ingress protection

- with closed housing: IP 67, NEMA 6
- with open housing: IP 20, NEMA 1
- Sensor: IP 68

Vibration resistance DIN IEC 68 T2-6 Tab. 2C (10 ... 55 Hz)

Electromagnetic compatibility (EMC)

- Interference emission to EN 61326, Equipment class B
- Interference immunity to EN 61326, Appendix A (Industrial) und NAMUR recommendation NE 21 (EMC)

Process conditions

Process temperature -40°C ... +80°C

Process pressure 0,7 ... 3 bar abs.

Mechanical construction

Design / Dimensions

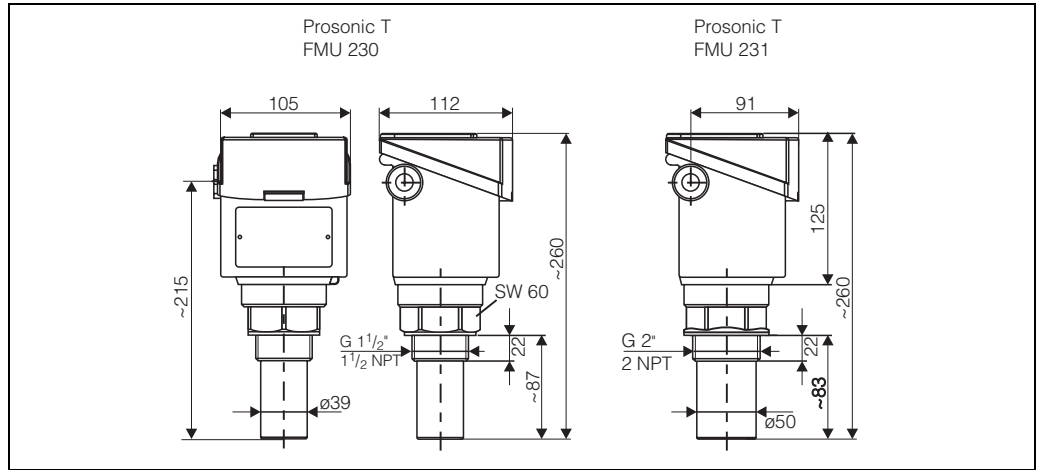

L00-FMU\XXXX-06-00-00-XX-002

Weight

Instrument	Weight
FMU 230	approx. 1,5 kg
FMU 231	approx. 1,6 kg

Housing material

PBT glass reinforced / flame-retended

Process connection

Instrument	Process connection	seal and sensor material
FMU 230	<ul style="list-style-type: none"> ■ thread G 1 1/2" ■ thread NPT 1 1/2" - 11,5 	PVDF / EPDM
FMU 231	<ul style="list-style-type: none"> ■ thread 2" ■ thread NPT 2" - 11,5 	PVDF / EPDM

Human interface

Operating elements

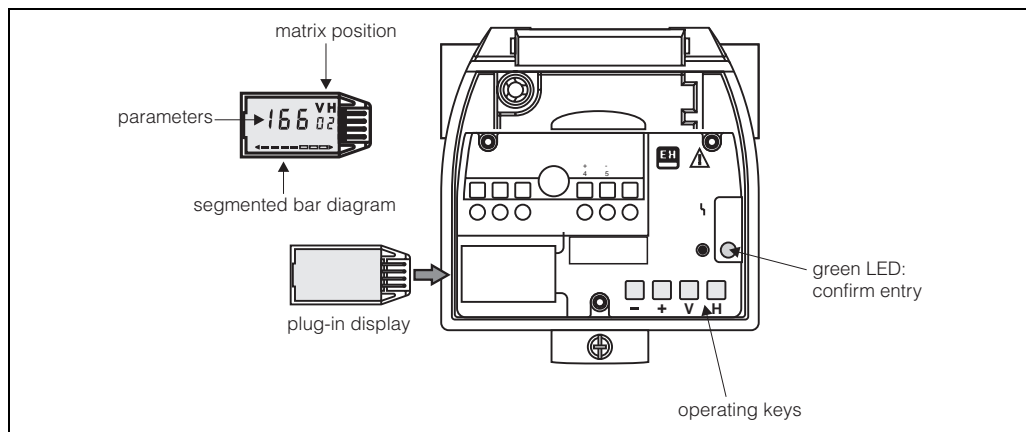

L00-FM1UX3XXX-19-00-03-en-002

LED Pressing of a key is confirmed by a flash of the green LED.

Display module (optional) When the display module is used, the Prosonic T is operated via an operating matrix. The current matrix position and the associated parameter (e.g. measured value) are displayed on the module. The bargraph represents the measured value or the echo quality, depending on the matrix position. The basic functions for simple applications (empty and full calibration, locking and unlocking) are accessible without the display module.

Certificates and Approvals

CE mark The measuring system meets the legal requirements of the EC-guidelines on firms the instrument passing the required tests by attaching the CE-mark.

External standards and guidelines

EN 60529
Protection class of housing (IP-code)

EN 61326
Electromagnetic compatibility (EMC requirements)

NAMUR
Standards committee for measurement and control in the chemical industry

Ordering information

Product structure

		Version	
	E	Europe / Asia (cylindrical thread „G“)	
	A	America (conical thread „NPT“)	
		Certificate	
	A	Standard	
	N	CSA General Purpose (for Version A only)	
		Communication	
	A	4...20mA, 2-wire	
		Housing/cable entry	
	2	Plastic housing NEMA 6, NPT ½	
	3	Plastic housing IP 67, M 20x1,5 (for Version E only)	
	4	Plastic housing IP 67, G ½ (for Version E only)	
		Display	
	1	without display module	
	2	with display module	
FMU 230	-		product designation
FMU 231	-		product designation

Scope of delivery

- Instrument in the ordered version
- Operating Instructions
- for versions FMU 230E and FMU 231E: Counter nut (PC)
- EPDM process seal
- for versions M20x1,5: cable gland

Accessories

Protective cover

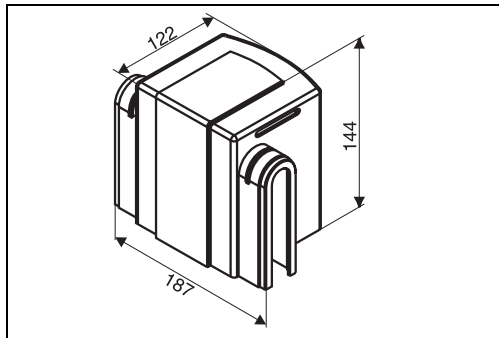

Order-Code:
942665-0000

L00-FMUX3XXX-06-00-06-XX-001

Adapter flange

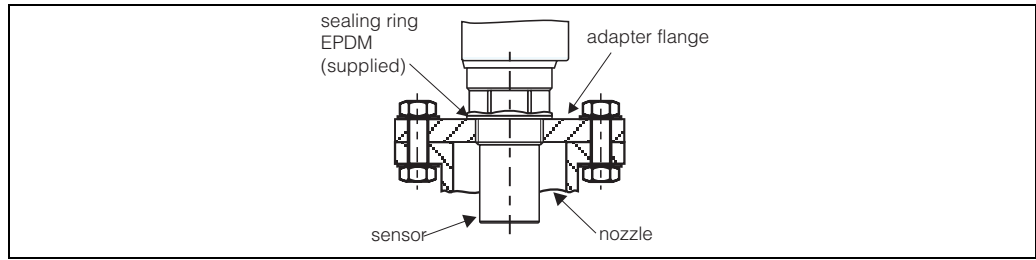

L00-FMU1X3XXX-00-00-00-es-001

Version with metrical thread (FAU 70 E)

Process Connection	
12	DN 50 PN 16 A, flange EN1092-1 (DIN2527 B)
14	DN 80 PN 16 A, flange EN1092-1 (DIN2527 B)
15	DN 100 PN 16, A, flange EN1092-1 (DIN2527 B)
Sensor Connection	
3	Thread ISO228 G1-1/2
4	Thread ISO228 G2
Flange Material	
2	316L
7	Polypropylene

FAU 70 E	Product designation
----------	---------------------

Version with conical thread (FAU 70 A)

Process Connection	
22	2" 150lbs FF, flange ANSI B16.5
24	3" 150lbs FF, flange ANSI B16.5
25	4" 150lbs FF, flange ANSI B16.5
Sensor Connection	
5	Thread NPT1-1/2
6	Thread NPT2
Flange Material	
2	316L
7	Polypropylene

FAU 70 A	Product designation
----------	---------------------

Mounting bracket

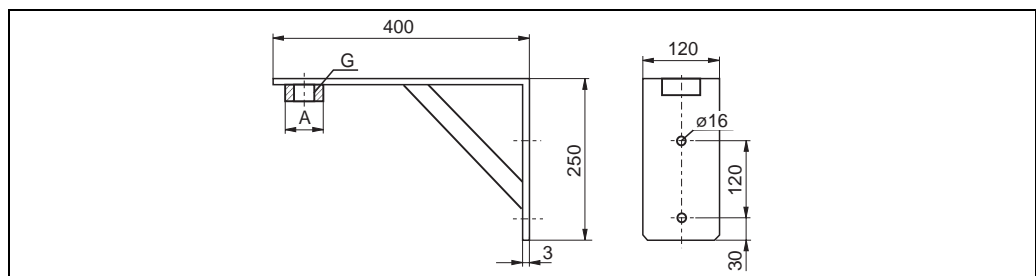

L00-FMU4x-00-00-00-de-001

- for FMU 230, G1½: Order code: 942669-0000
- for FMU 231, G2: Order code: 942669-0001
- Material: 316 Ti
- suited for NPT 1½" und 2" as well

Cantilever

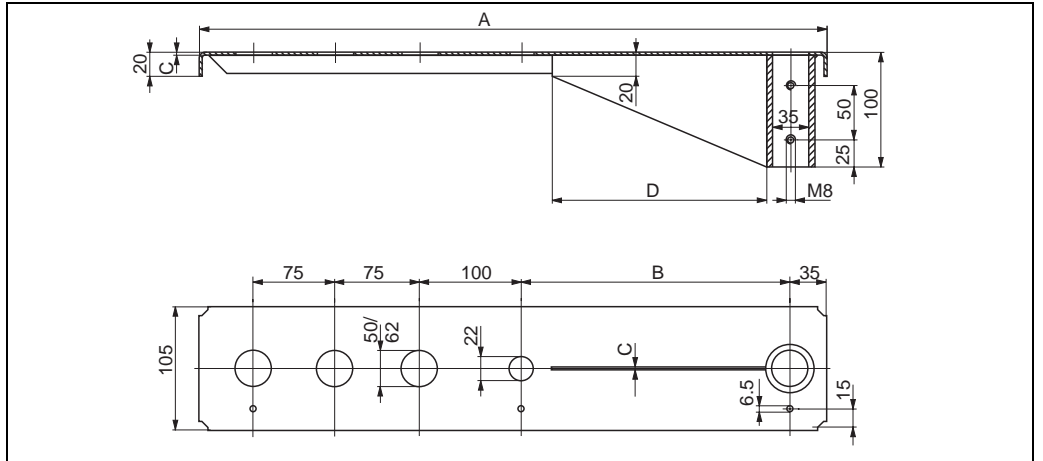

100-FMU14xxxx-06-00-00-yy-005

A	B	C	D	for Sensor	Material	Order Code
585 mm	250 mm	2 mm	200 mm	FMU 230	1.4301 (AISI 304)	52014132
					galv. steel	52014131
				FMU 231	1.4301 (AISI 304)	52014136
					galv. steel	52014135
1085 mm	750 mm	3 mm	300 mm	FMU 230	1.4301 (AISI 304)	52014134
					galv. steel	52014133
				FMU 231	1.4301 (AISI 304)	52014138
					galv. steel	52014137

The 50 mm or 62 mm orifices serve for the mounting of the FMU 230 or FMU 231 sensor, respectively.

Mounting bracket

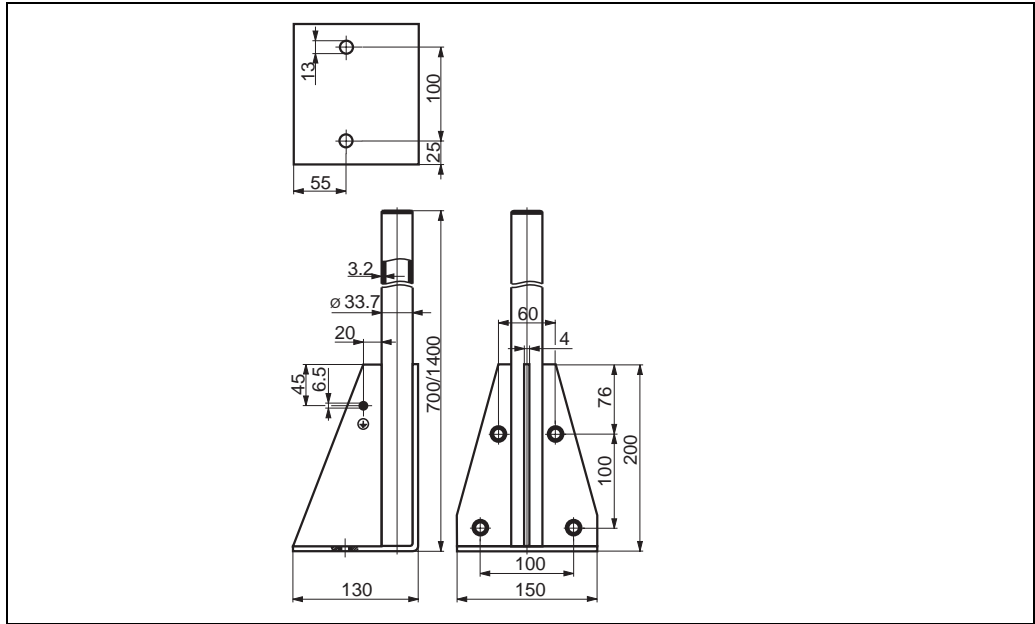

L00-FM14x-00-00-00-yy-005

Height	Material	Order Code
700 mm	galv. steel	919791-0000
700 mm	316 Ti	919791-0001
1400 mm	galv. steel	919791-0002
1400 mm	316 Ti	919791-0003

Wall bracket for cantilever

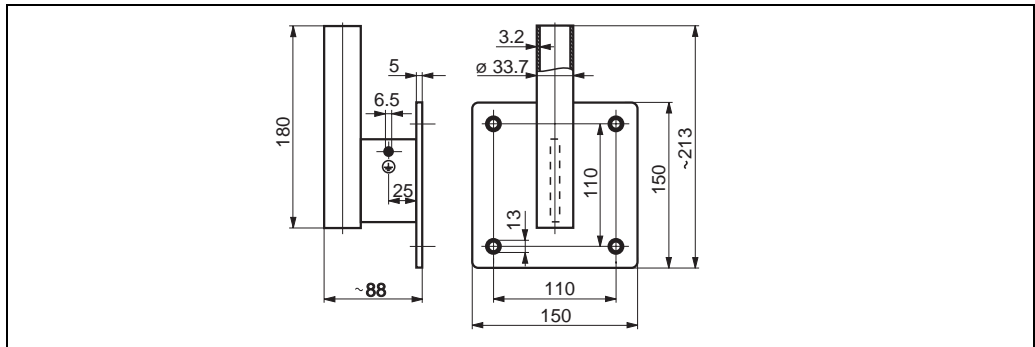

L00-FM14x-00-00-00-yy-005

Material	Order Code
galv. steel	919792-0000
316 Ti	919792-0001

По вопросам продаж и поддержки обращайтесь:

Алматы (7273)495-231
Ангарск (3955)60-70-56
Архангельск (8182)63-90-72
Астрахань (8512)99-46-04
Барнаул (3852)73-04-60
Белгород (4722)40-23-64
Благовещенск (4162)22-76-07
Брянск (4832)59-03-52
Владивосток (423)249-28-31
Владикавказ (8672)28-90-48
Владимир (4922)49-43-18
Волгоград (844)278-03-48
Вологда (8172)26-41-59
Воронеж (473)204-51-73
Екатеринбург (343)384-55-89

Иваново (4932)77-34-06
Ижевск (3412)26-03-58
Иркутск (395)279-98-46
Казань (843)206-01-48
Калининград (4012)72-03-81
Калуга (4842)92-23-67
Кемерово (3842)65-04-62
Киров (8332)68-02-04
Коломна (4966)23-41-49
Кострома (4942)77-07-48
Краснодар (861)203-40-90
Красноярск (391)204-63-61
Курск (4712)77-13-04
Курган (3522)50-90-47
Липецк (4742)52-20-81

Магнитогорск (3519)55-03-13
Москва (495)268-04-70
Мурманск (8152)59-64-93
Набережные Челны (8552)20-53-41
Новокузнецк (3843)20-46-81
Ноябрьск (3496)41-32-12
Новосибирск (383)227-86-73
Омск (3812)21-46-40
Орел (4862)44-53-42
Оренбург (3532)37-68-04
Пенза (8412)22-31-16
Петрозаводск (8142)55-98-37
Псков (8112)59-10-37
Пермь (342)205-81-47

Ростов-на-Дону (863)308-18-15
Рязань (4912)46-61-64
Самара (846)206-03-16
Санкт-Петербург (812)309-46-40
Саратов (845)249-38-78
Севастополь (8692)22-31-93
Саранск (8342)22-96-24
Симферополь (3652)67-13-56
Смоленск (4812)29-41-54
Сочи (862)225-72-31
Ставрополь (8652)20-65-13
Сургут (3462)77-98-35
Сыктывкар (8212)25-95-17
Тамбов (4752)50-40-97
Тверь (4822)63-31-35

Тольятти (8482)63-91-07
Томск (3822)98-41-53
Тула (4872)33-79-87
Тюмень (3452)66-21-18
Ульяновск (8422)24-23-59
Улан-Удэ (3012)59-97-51
Уфа (347)229-48-12
Хабаровск (4212)92-98-04
Чебоксары (8352)28-53-07
Челябинск (351)202-03-61
Череповец (8202)49-02-64
Чита (3022)38-34-83
Якутск (4112)23-90-97
Ярославль (4852)69-52-93

Россия +7(495)268-04-70

Казахстан +7(7172)727-132

Киргизия +996(312)96-26-47

эл.почта: ehr@nt-rt.ru || сайт: <https://endcounters.nt-rt.ru/>